

Inhoudsopgave

Drijfwerk Huis	24
Handels op Stuur	94
Index	128
Koppeling	14
Motorsteun & kapjes	4
PTO & Tandwielen 2004	34
PTO & Tandwielen Start 809850	40
PTO & Tandwielen Start 937702	48
Schakelpoken 2004	82
Schakelpoken 2009	86
Stickers 2004-1	112
Stickers 2006-1	114
Stickers 2009-1	116
Stickers 2010-1	118
Stuur & Kabels 2004	68
Stuur & kabels 2006	72
Stuur & Kabels 2009	76
Stuurboom 2004	54
Stuurboom 2008	58
Stuurboom 2009	60
Wielas & Wielflenzen 2004	46
Wielas & Wielflenzen 2006	52
Wielen 2004	96
Wielen 2008	104
Wielen 2010	108

Code	Description	Notes
C01_0_22466	ENGINE GUARDS	
C01_1_34043	ENGINE GUARDS	
C01_2_67668	ENGINE GUARDS	
C.01.02.A0011_03	ENGINE GUARDS	
C.01.02.A0011_04	ENGINE GUARDS	
D01_0_22506	CLUTCH	
D01_1_27654	CLUTCH	
D01_2_33546	CLUTCH	
D01_3_59819	CLUTCH	
D01_4_72864	CLUTCH	
E01_0_22534	GEARBOX	
E01_1_23274	GEARBOX	
E01_2_67697	GEARBOX	
E.01.02.A0011_03	GEARBOX	
E.01.02.A0011_04	GEARBOX	
F02_0_22647	GEARBOX	
F02_1_59847	GEARBOX	
F02_2_67738	GEARS	
G01_0_22724	WHEEL AXLE	
F.02.02.A0011_03	GEARS	
G01_1_34130	WHEEL AXLE	
H01_0_22844	STEERING COLUMN	
H01_1_59887	STEERING COLUMN	
H01_2_67804	STEERING COLUMN	Version: 515GR, 515L GR, 515S GR, 515SL GR
H.01.02.A0011_03	STEERING COLUMN	
I01_0_22914	HANDLEBAR	
I01_1_32971	HANDLEBAR	
I01_2_67839	HANDLEBAR	Version: 515GR, 515L GR, 515S GR, 515SL GR
I.01.02.A0011_03	HANDLEBAR	
J01_0_23105	CONTROLS	
J01_1_67885	CONTROLS	Version: 515GR, 515L GR, 515S GR, 515SL GR
J.01.02.A0011_02	CONTROLS	
J.03.02.A0011_00	HANDLEBAR CONTROLS	
L01_0_23182	WHEELS	

Code	Description	Notes
L01_1_27708	WHEELS	
L01_2_60486	WHEELS	
L01_3_90714	WHEELS	
M01_0_23235	STICKERS	
M01_1_34253	STICKERS	
M01_2_67927	STICKERS	
M01_3_91676	STICKERS	
M02_0_23244	STICKERS	
M02_1_34264	STICKERS	
M02_2_67938	STICKERS	
M02_3_91699	STICKERS	

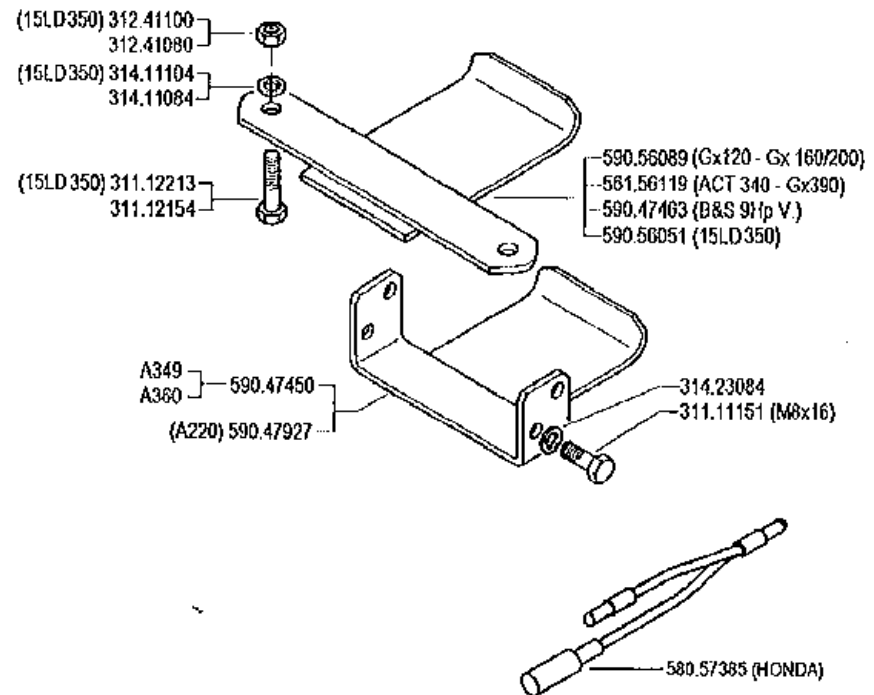
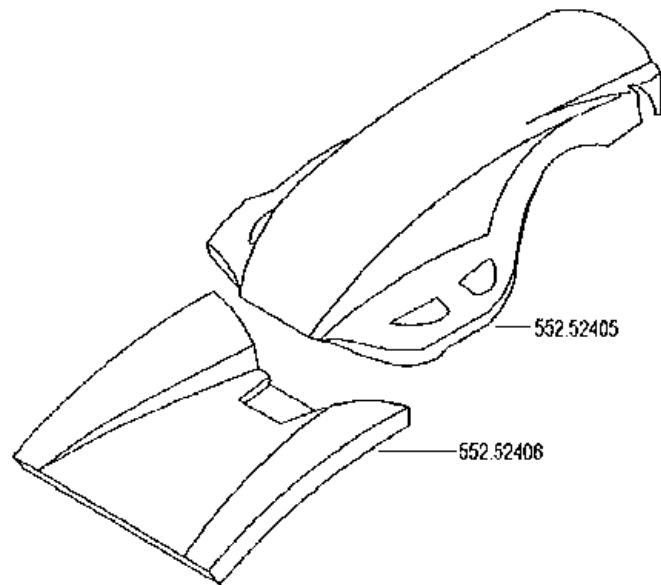

FERRARI

500 serie GRIFON

ENGINE GUARDS
PROTECCIONES MOTOR

RIPARI MOTORE
(515GR - 515L GR - 515S GR)

PROTECTIONS MOTEUR
MOTOR SCHUTZ

DALLA MACCHINA
DE LA MAQUINA
DE LA MACHINE
FROM THE MACHINE
AB DER MASCHINE

N.

C01 0

09/2004

Rev.

23/04

Pos.	Code	Q.ty	Description	Notes
31111151	31111151	1	SCREW TE M8X16 UNI 5739 8G	
31112154	31112154	1	SCREW TE M8X40 UNI 5739 8G	
31112213	31112213	1	SCREW TE M10X40 UNI 5739	
31241080	31241080	1	SELFLOCK NUT M8	
31241100	31241100	1	SELFLOCK NUT M10 6S	
31411084	31411084	1	WASHER 8,4x17	
31411104	31411104	1	WASHER 10,5x18	
31423084	31423084	1	SPRING WASHER 8,4	
55252405	55252405	1	GUARD	
55252406	55252406	1	GUARD	
56156119	56156119	1	SHIELD	
58057385	58057385	1	LINE	
59047450	59047450	1	SHIELD	
59047463	59047463	1	ENGINE PROTECTION	
59047927	59047927	1	SHIELD	
59056051	59056051	1	SHIELD	
59056089	59056089	1	SHIELD	

500 GR ★

- ★ 56152241
- ★ 31421083
- ★ 31121007

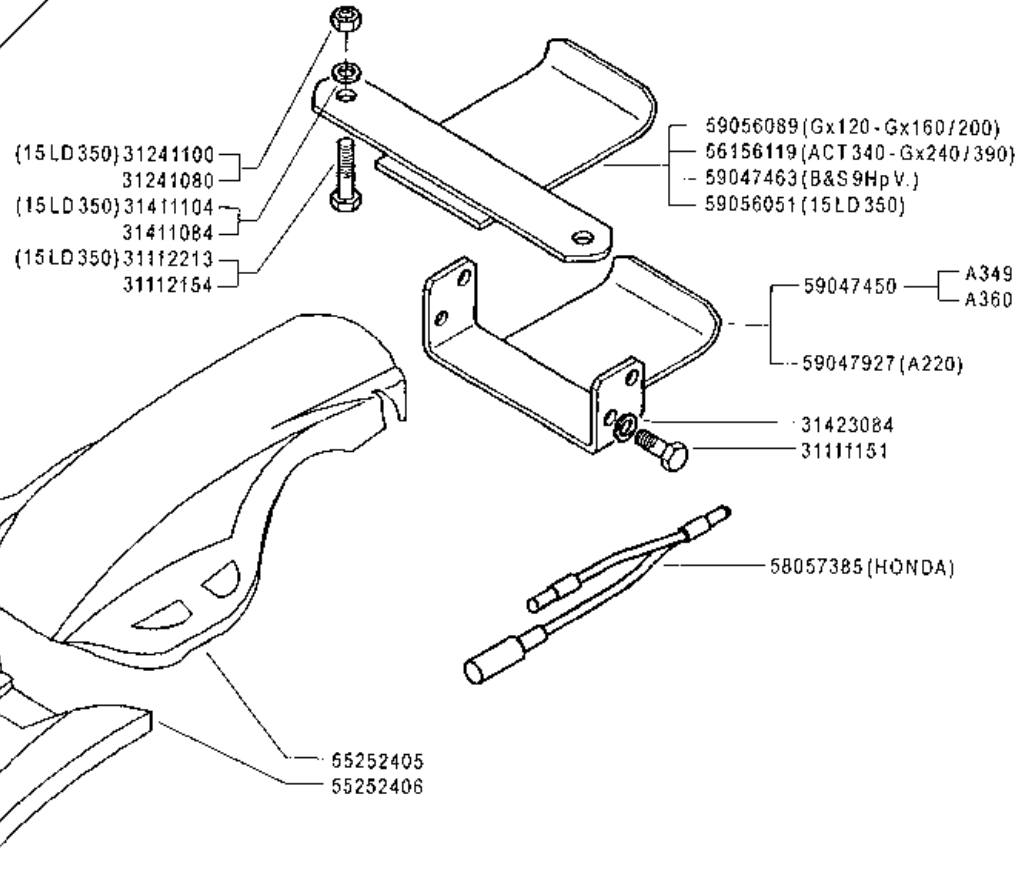

FERRARI

500 serie GRIFON

RIPARI MOTORE
(500GR ★ - 515GR - 515L GR - 515S GR)
 ENGINE GUARDS
 PROTECCIONES MOTOR
 PROTECTIONS MOTEUR
 MOTOR SCHUTZ

DALLA MACCHINA
 DE LA MAQUINA
 DE LA MACHINE
 FROM THE MACHINE
 AB DER MASCHINE

★ N.

AGGIORNAMENTO
 REVISION
 MISE A JOUR
 APLAZAMIENTO
 ANPASSUNG

C01

06/2006

Rev
1

ZENIT

Pos.	Code	Q.ty	Description	Notes
31111151	31111151	1	SCREW TE M8X16 UNI 5739 8G	
31112154	31112154	1	SCREW TE M8X40 UNI 5739 8G	
31112213	31112213	1	SCREW TE M10X40 UNI 5739	
31121007	31121007	1	SCREW BCEI M8X20 ISO7380	
31241080	31241080	1	SELFLOCK NUT M8	
31241100	31241100	1	SELFLOCK NUT M10 6S	
31411084	31411084	1	WASHER 8,4x17	
31411104	31411104	1	WASHER 10,5x18	
31421083	31421083	1	WASHER	
31423084	31423084	1	SPRING WASHER 8,4	
55252405	55252405	1	GUARD	
55252406	55252406	1	GUARD	
56152241	56152241	1	CARROZZERIA MF LAT./97 *V*	
56156119	56156119	1	SHIELD	
58057385	58057385	1	LINE	
59047450	59047450	1	SHIELD	
59047463	59047463	1	ENGINE PROTECTION	
59047927	59047927	1	SHIELD	
59056051	59056051	1	SHIELD	
59056089	59056089	1	SHIELD	

500 GR

(1) ★ 56156990V
31121007
31421083

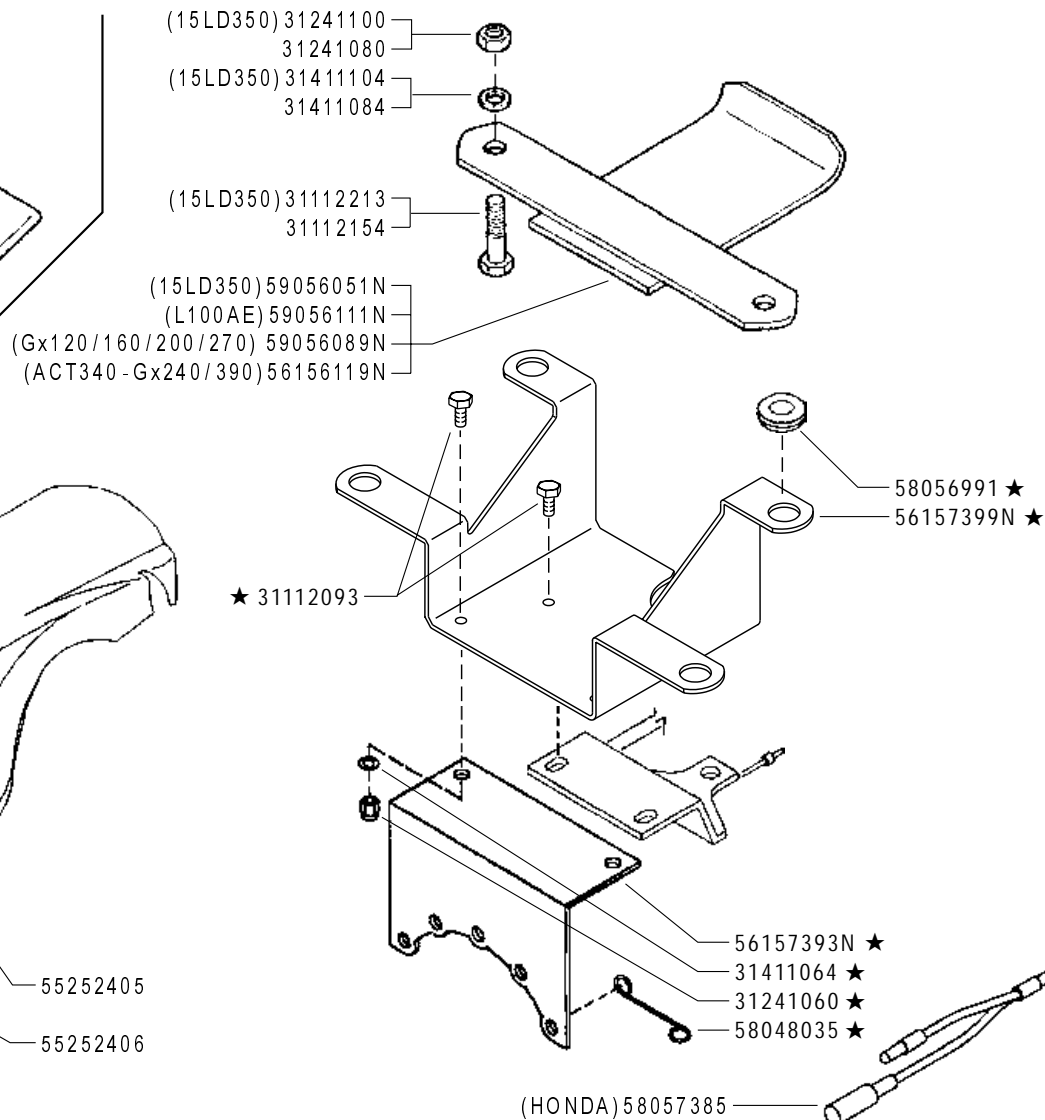
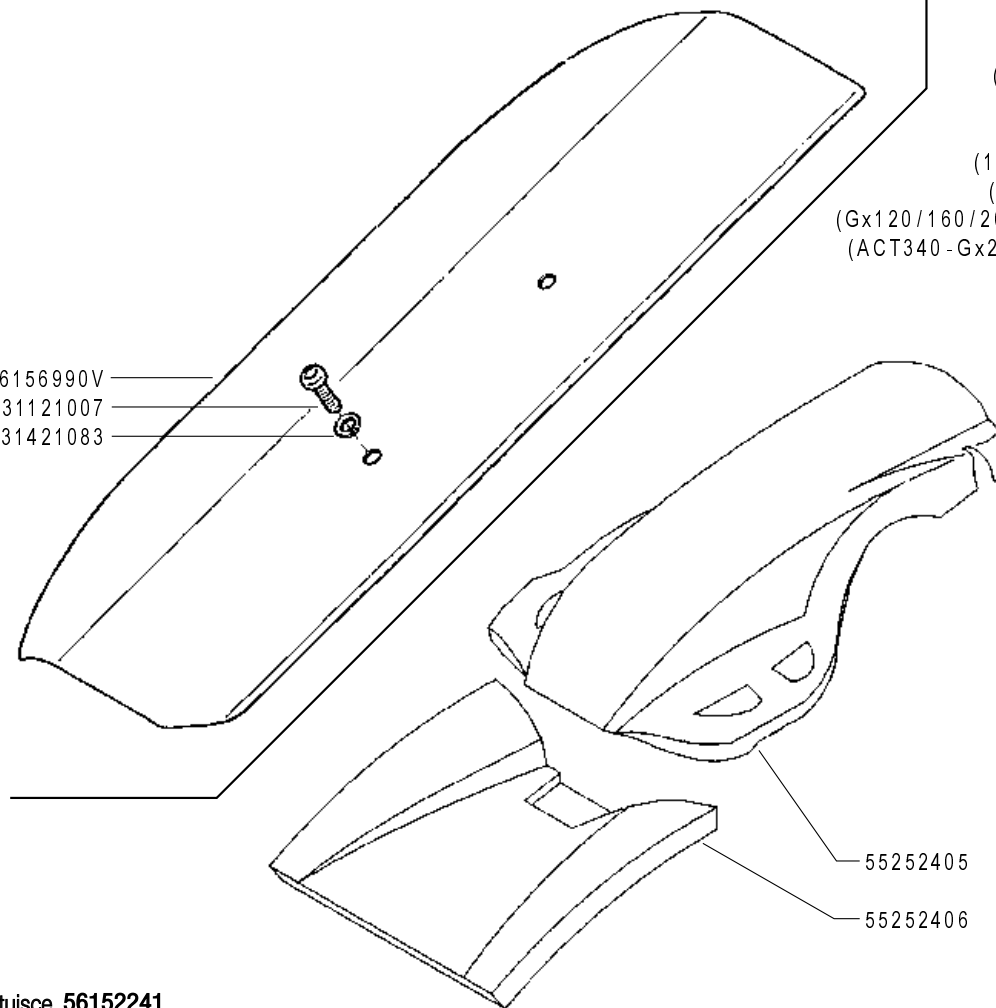

(1) sostituisce 56152241

FERRARI

500 serie GRIFON

RIPARI MOTORE

(500GR - 515GR - 515L GR - 515S GR - 515SL GR ★)

ENGINE GUARDS
PROTECCIONES MOTOR

PROTECTIONS MOTEUR
MOTOR SCHUTZ

DALLA MACCHINA
DE LA MAQUINA
DE LA MACHINE
FROM THE MACHINE
AB DER MASCHINE

AGGIORNAMENTO

REVISION

MISE A JOUR

APLAZAMIENTO

ANPASSUNG

★ N.

C01

02/2009

Rev.
2

ZENNE

Pos.	Code	Q.ty	Description	Notes
0	0	1		
31112093	31112093	1	SCREW TE M6X20 UNI 5739 8G	
31112154	31112154	1	SCREW TE M8X40 UNI 5739 8G	
31112213	31112213	1	SCREW TE M10X40 UNI 5739	
31121007	31121007	1	SCREW BCEI M8X20 ISO7380	
31241060	31241060	1	SELFLOCK NUT M6	
31241080	31241080	1	SELFLOCK NUT M8	
31241100	31241100	1	SELFLOCK NUT M10 6S	
31411064	31411064	1	WASHER 6,4x12,5	
31411084	31411084	1	WASHER 8,4x17	
31411104	31411104	1	WASHER 10,5x18	
31421083	31421083	1	WASHER	
55252405	55252405	1	GUARD	
55252406	55252406	1	GUARD	
58048035	58048035	1	HOLDER	
58056991	58056991	1	CABLE GLAND	
58057385	58057385	1	LINE	
59056111	59056111	1	SHIELD	
56156119	56156119N	1	SHIELD	
56156990	56156990V	1	BODYWORK	
56157393	56157393N	1	HOLDER	
56157399	56157399N	1	HOLDER	
59056051	59056051N	1	SHIELD	
59056089	59056089N	1	SHIELD	

500 GR

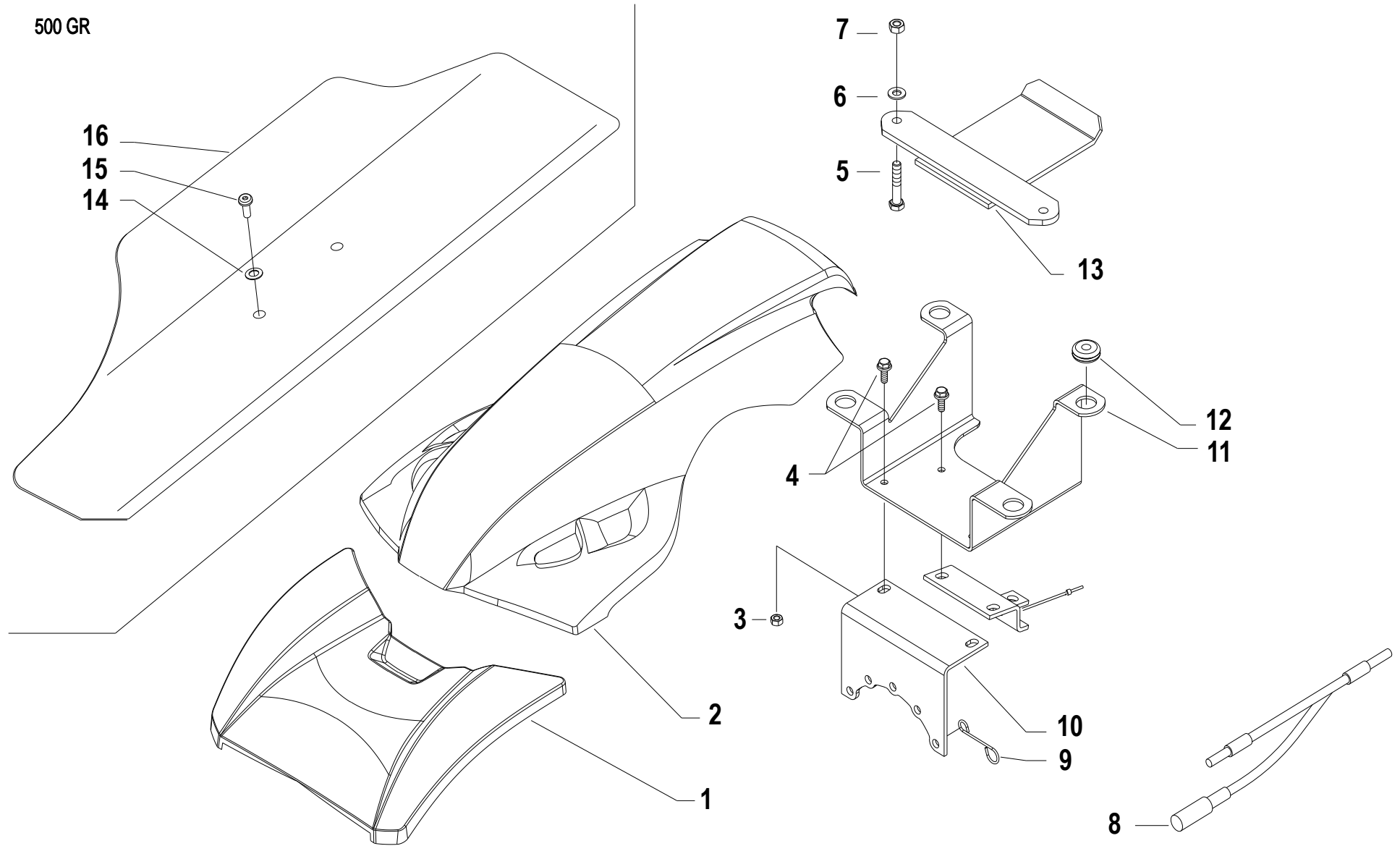

Pos.	Code	Q.ty	Description	Notes
1	55252406	1	GUARD	
2	55252405	1	GUARD	
3	31241065	1	SELFLOCK NUT M6	
4	31112085	1	SCREW TE M6X16 DIN 6921 8G	
5	31112154	1	SCREW TE M8X40 UNI 5739 8G	
5	31112213	1	SCREW TE M10X40 UNI 5739	For the engine 15LD350
6	31411084	1	WASHER 8,4x17	
6	31411104	1	WASHER 10,5x18	For the engine 15LD350
7	31241080	1	SELFLOCK NUT M8	
7	31241100	1	SELFLOCK NUT M10 6S	For the engine 15LD350
8	58057385	1	LINE	
9	58048035	1	HOLDER	
10	56157393N	1	HOLDER	
11	56157399N	1	HOLDER	
12	58056991	1	CABLE GLAND	
13	56156119N	1	SHIELD	For motors ACT340 / GX240 / GX270 / GX390
13	59056051	1	SHIELD	For the engine 15LD350
13	59056089N	1	SHIELD	For motors GX120 / GX160 / GX200 / EX21
13	59056111N	1	SHIELD	For the engine L100AE
14	31421083	1	WASHER	
15	31121007	1	SCREW BCEI M8X20 ISO7380	
16	56156990V	1	BODYWORK	

ENGINE GUARDS

SERIAL START 953111

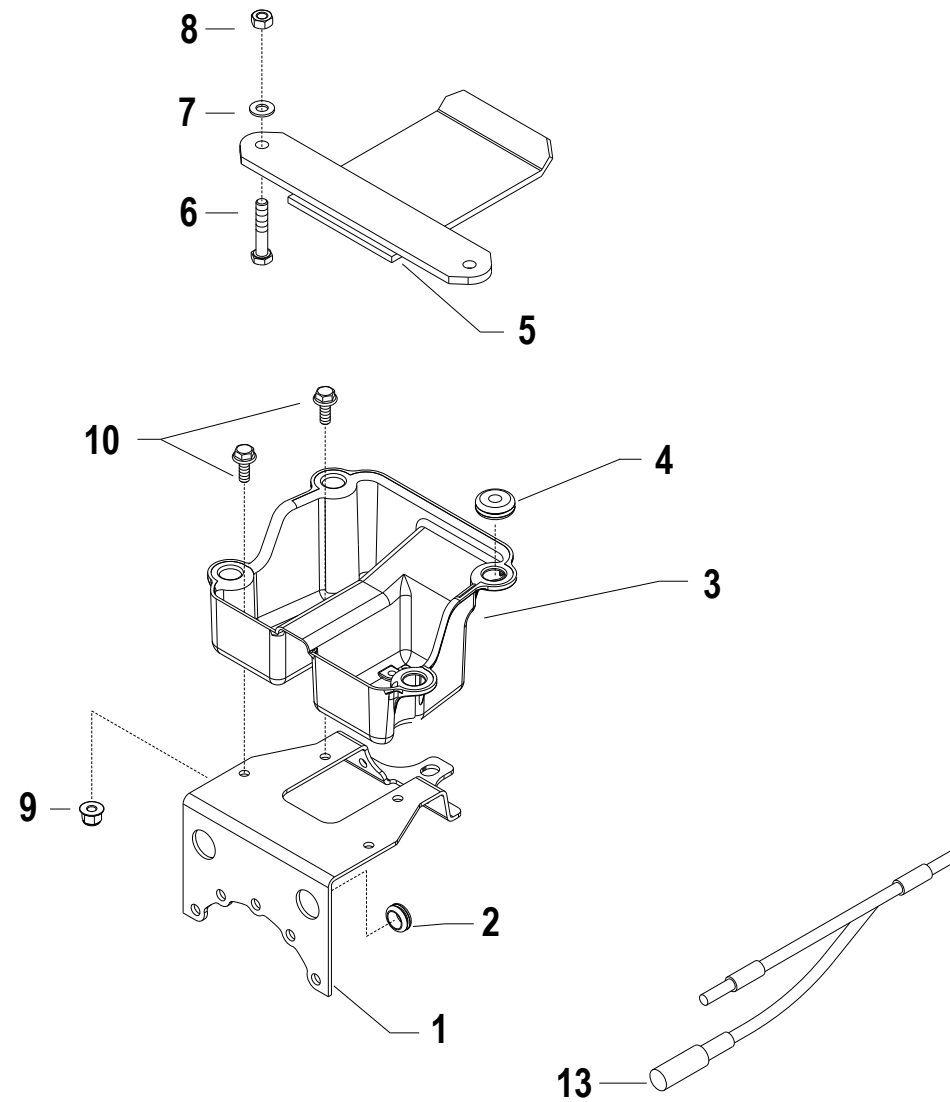
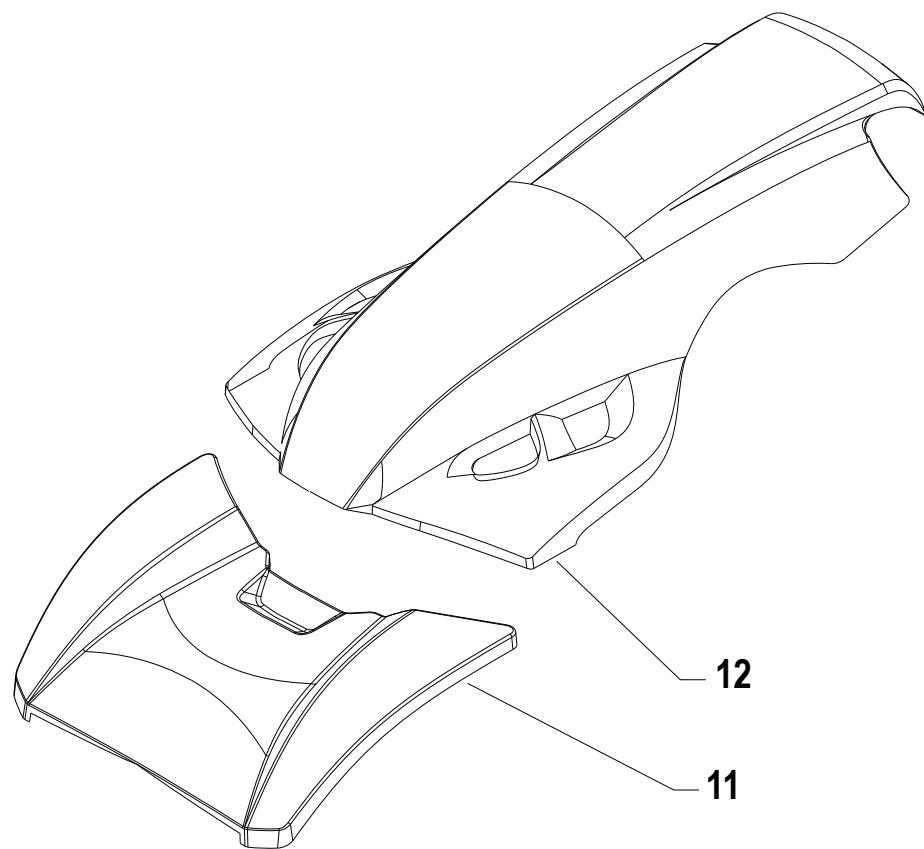

Pos.	Code	Q.ty	Description	Notes
1	561C1002N		SOSTEGNO SCATOLA BATTERIA C/C	
2	581C1004		PASSACAVO 18X22X27X3 DK	
3	552C1001		COFANETTO SOST.CARENATURA	Replaces 56157399N
4	58056991		CABLE GLAND	
5	56156119N		SHIELD	ACT340/GX240/GX270/GX390
5	59056051N		SHIELD	15LD350
5	59056089N		SHIELD	GX120/GX160/GX200/EX21
5	59056111N		SHIELD	L100AE
6	31112154		SCREW TE M8X40 UNI 5739 8G	
6	31112213		SCREW TE M10X40 UNI 5739	15LD350
7	31411084		WASHER 8,4x17	
7	31411104		WASHER 10,5x18	15LD350
8	31241080		SELFLOCK NUT M8	
8	31241100		SELFLOCK NUT M10 6S	15LD350
9	31241066		SELFLOCK M6 FL NY DIN 6926	
10	31112081		SCREW TE C/F M6X20 DIN 6921 8G	
11	55252406		GUARD	
12	55252405		GUARD	
13	58057385		LINE	

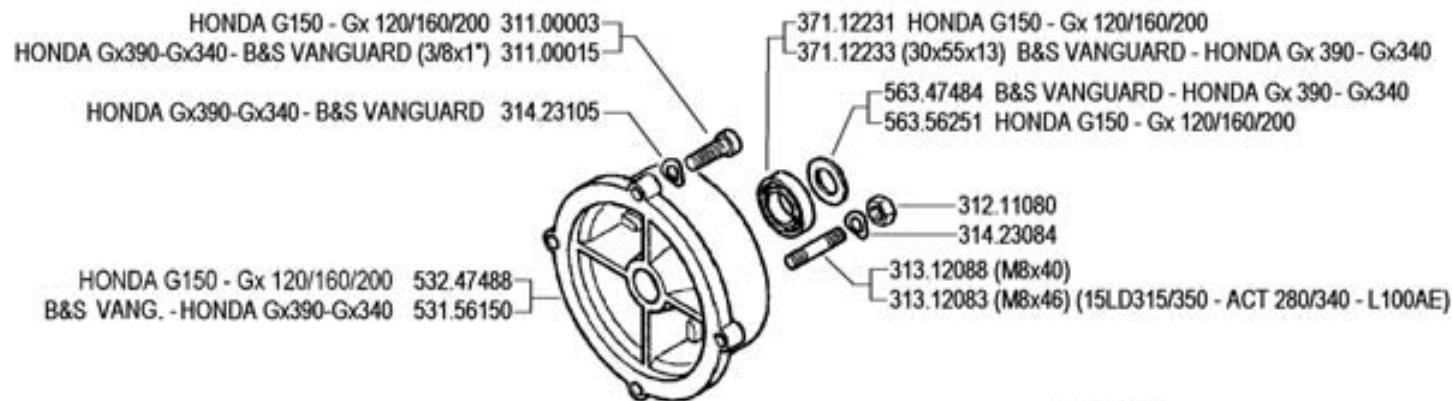

MOTORE ENGINE MOTEUR MOTOR MOTOR	A	FRIZIONE EMBRAGUE EMBRAYAGE KUPPLUNG CLUTCH
Acme A220	592.47884	
Acme ACT 280 - A349 - A360	592.47884	
Acme ACT 340	592.47971	
Briggs & Stratton 9 Hp Vanguard	592.56253	
Honda Gx 390-Gx340	592.56257	
Honda G150 - Gx 120 / 160 / 200	592.56265	
Lombardini 15LD315 / 350	592.47884	
Lombardini 6LD435 / 400	592.47971	
Yanmar L100AE	592.47971	

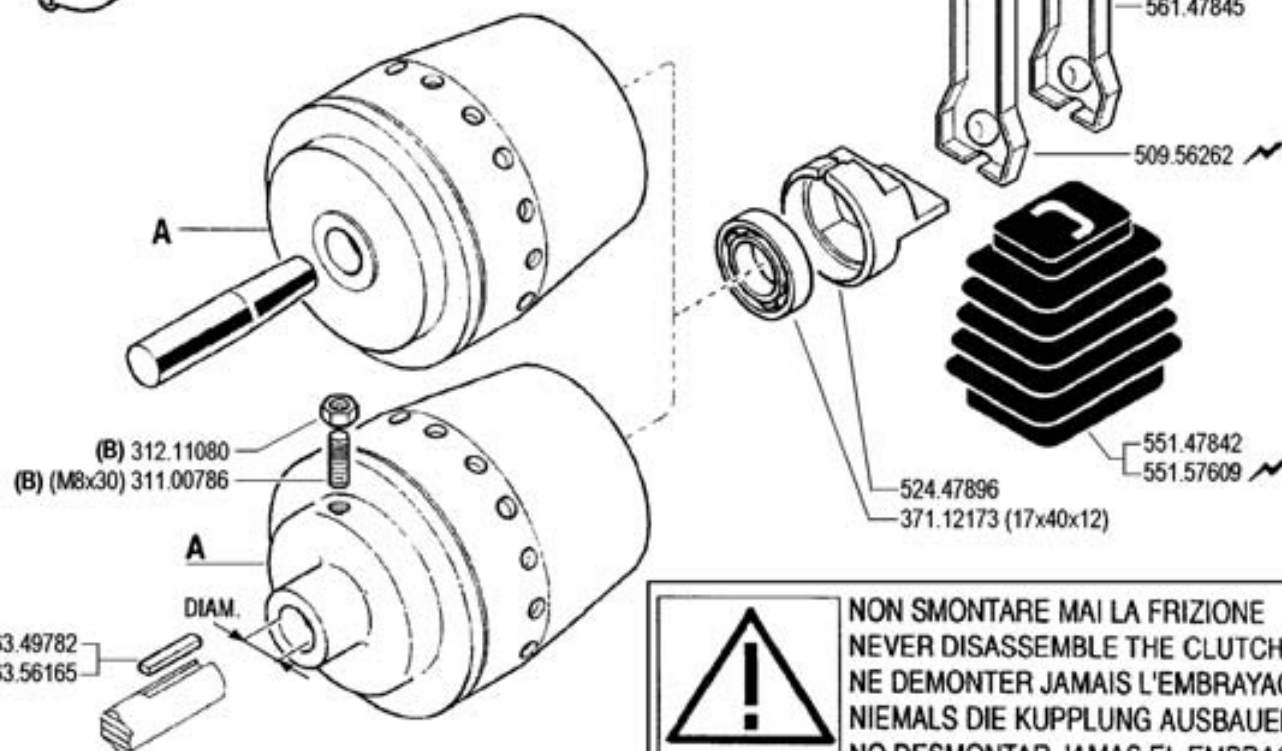

(HONDA Gx 390-Gx340-B&S VANGUARD) 563.49782
 (HONDA G150 - Gx120/160/200) 563.56165

NON SMONTARE MAI LA FRIZIONE
NEVER DISASSEMBLE THE CLUTCH
NE DEMONTER JAMAIS L'EMBRAYAGE
NIEMALS DIE KUPPLUNG AUSBAUEN
NO DESMONTAR JAMAS EL EMBRAGUE

(B) serrare a 2 Kg

FERRARI

500 serie GRIFON

FRIZIONE A CONO AUTOVENTILANTE

CLUTCH
EMBRAGUE

EMBRAYAGE
KUPPLUNG

DALLA MACCHINA
 DE LA MAQUINA
 DE LA MACHINE
 FROM THE MACHINE
 AB DER MASCHINE

N.

D01

Rev.

0

09/2004

ZENE

Pos.	Code	Q.ty	Description	Notes
31100003	31100003	1	SCREW TE 5/16X7/8	
31100015	31100015	1	SCREW TE 3/8X1	
31100786	31100786	1	SCREW STEI M8X30 UNI5923 8G	
31211080	31211080	1	NUT M8	
31312083	31312083	1	STUD BOLT M8X46X16X16	
31312088	31312088	1	STUD BOLT M8X40X14X14	
31423084	31423084	1	SPRING WASHER 8,4	
31423105	31423105	1	SPRING WASHER 10,5	
37112173	37112173	1	BEARING	
37112231	37112231	1	BEARING	
37112233	37112233	1	BEARING	
50956262	50956262	1	CLUTCH LEVER	
52447896	52447896	1	PRESSURE PLATE	
53156150	53156150	1	ENGINE FLANGE	
53247488	53247488	1	ENGINE FLANGE	
55147842	55147842	1	BELLOWS	
55157609	55157609	1	BELLOWS	
56147845	56147845	1	CLUTCH LEVER	
56347484	56347484	1	SHIM	
56349782	56349782	1	DOWEL	
56356165	56356165	1	DOWEL	
56356251	56356251	1	SHIM D=19,6	
59247884	59247884	1	CLUTCH ASSY	
59247971	59247971	1	CLUTCH	
59256253	59256253	1	CLUTCH ASSY	
59256257	59256257	1	CLUTCH ASSY	
59256265	59256265	1	CLUTCH ASSY	

SERIAL

CLUTCH

CODE REV

D01_0_22506

HONDA G150 - Gx120/160/200 31100003
 HONDA Gx390 - Gx340 (3/8x1") 31100015

HONDA Gx390 - Gx340 31423105

HONDA G150 - Gx120/160/200 53247488
 HONDA Gx390 - Gx340 53156150

37112231 HONDA G150 - Gx120/160/200
 37112233 (30x55x13) HONDA Gx390 - Gx340

56347484 HONDA Gx390 - Gx340
 56356251 HONDA G150 - Gx120/160/200

31211080
 31423084

31312088 (M8x40)
 31312083 (M8x46)
 (15LD315/350 - ACT280/340 - L100AE)

56147845
 50956262 ⚡
 52447896

55147842
 55157609 ⚡

MOTORE ENGINE MOTEUR MOTOR	FRIZIONE CLUTCH A EMBRAYAGE EMBRAGUE KUPPLUNG
Acme A220	59247884
Acme ACT 280 - A349 - A360	59247884
Acme ACT 340	59247971
Honda Gx 390 - Gx 340 D=25,4	59256280 ★(2)
Honda G150 - Gx120/160/200 D=19	59256275 ★(1)
Lombardini 15LD315/350	59247884
Lombardini 6LD435/400	59247971
Yanmar L100AE	59247971

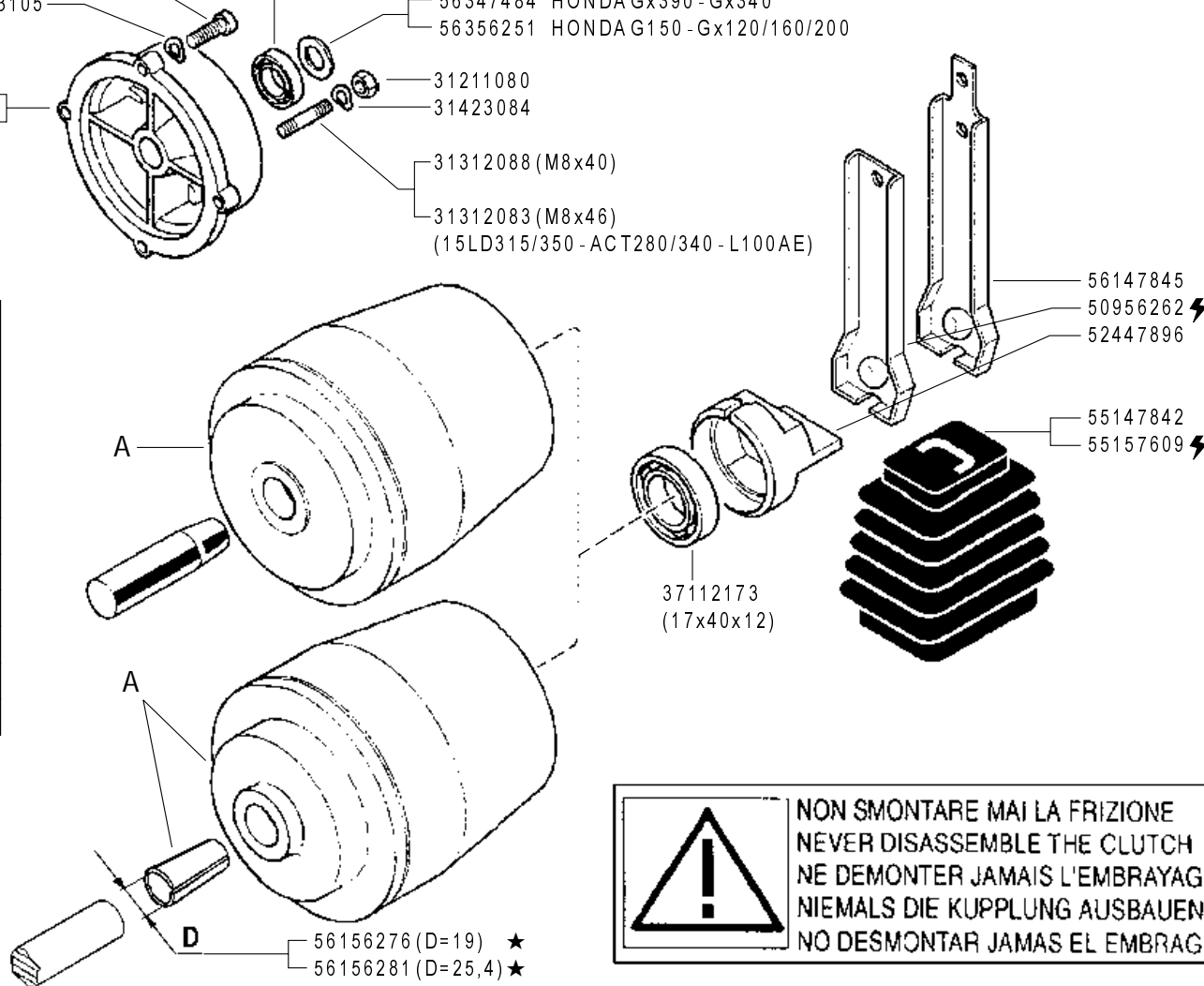

(2) sostituisce 59256257
 (1) sostituisce 59256265

**! NON SMONTARE MAI LA FRIZIONE
 NEVER DISASSEMBLE THE CLUTCH
 NE DEMONTER JAMAIS L'EMBRAYAGE
 NIEMALS DIE KUPPLUNG AUSBAUEN
 NO DESMONTAR JAMAS EL EMBRAGUE**

FERRARI

500 serie GRIFON

FRIZIONE A CONO AUTOVENTILANTE

CLUTCH
 EMBRAGUE

EMBRAYAGE
 KUPPLUNG

DALLA MACCHINA
 DE LA MAQUINA
 DE LA MACHINE
 FROM THE MACHINE
 AB DER MASCHINE

CHIEDERE A S.A.T.
 ASK TO S.A.T.
 DEMANDER A S.A.T.
 SOLICITAR EL S.A.T.
 ANFRAGEN DER S.A.T.

★ N.

D01

Rev. 1

11/2006

ZENNE

Pos.	Code	Q.ty	Description	Notes
31100003	31100003	1	SCREW TE 5/16X7/8	
31100015	31100015	1	SCREW TE 3/8X1	
31211080	31211080	1	NUT M8	
31312083	31312083	1	STUD BOLT M8X46X16X16	
31312088	31312088	1	STUD BOLT M8X40X14X14	
31423084	31423084	1	SPRING WASHER 8,4	
31423105	31423105	1	SPRING WASHER 10,5	
37112173	37112173	1	BEARING	
37112231	37112231	1	BEARING	
37112233	37112233	1	BEARING	
50956262	50956262	1	CLUTCH LEVER	
52447896	52447896	1	PRESSURE PLATE	
53156150	53156150	1	ENGINE FLANGE	
53247488	53247488	1	ENGINE FLANGE	
55147842	55147842	1	BELLOWS	
55157609	55157609	1	BELLOWS	
56147845	56147845	1	CLUTCH LEVER	
56156276	56156276	1	SLEEVE	
56156281	56156281	1	CENTRING BUSH	
56347484	56347484	1	SHIM	
56356251	56356251	1	SHIM D=19,6	
59247884	59247884	1	CLUTCH ASSY	
59247971	59247971	1	CLUTCH	
59256275	59256275	1	CLUTCH ASSY	
59256280	59256280	1	CLUTCH ASSY	

SERIAL

CLUTCH

CODE REV

D01_1_27654

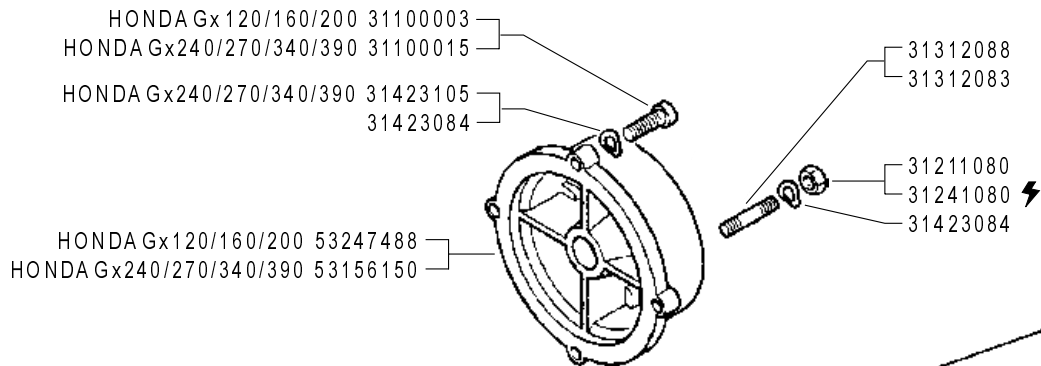

MOTORE ENGINE MOTEUR MOTOR MOTOR	FRIZIONE CLUTCH A EMBRAYAGE EMBRAGUE KUPPLUNG
Acme A220	59247884
Acme A220 (REF.)	59256255
Acme ACT280 - A349 - A360	59247884
Acme ACT340	59247971
Honda Gx390 - Gx340 D=25,4	59256280
Honda Gx240/270 D=25,4	59256279
Honda Gx120/160/200 D=19	59256275
Lombardini 15LD315/350	59247884
Lombardini 15LD500	59247924
Yanmar L100AE	59247971
Yanmar L70AE	59247884

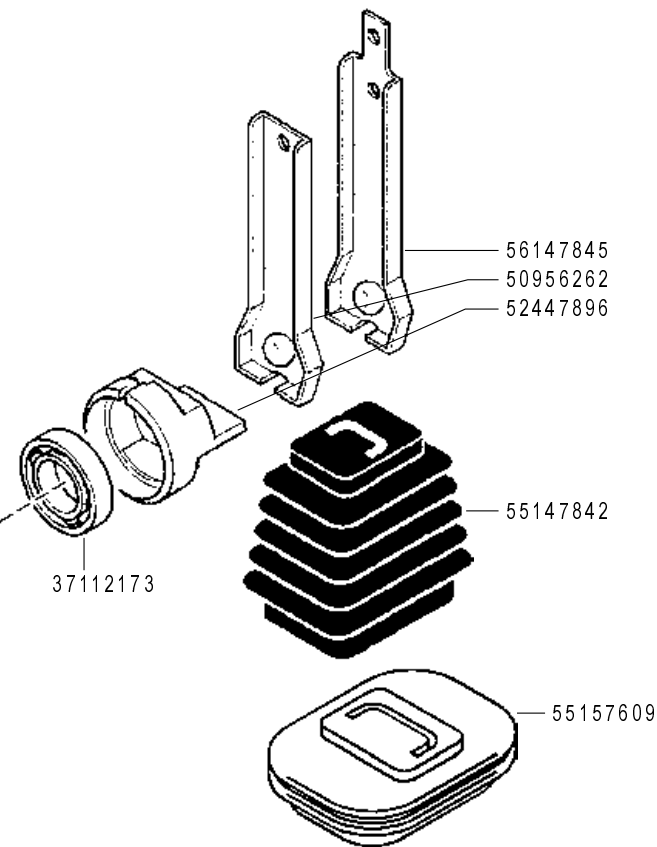
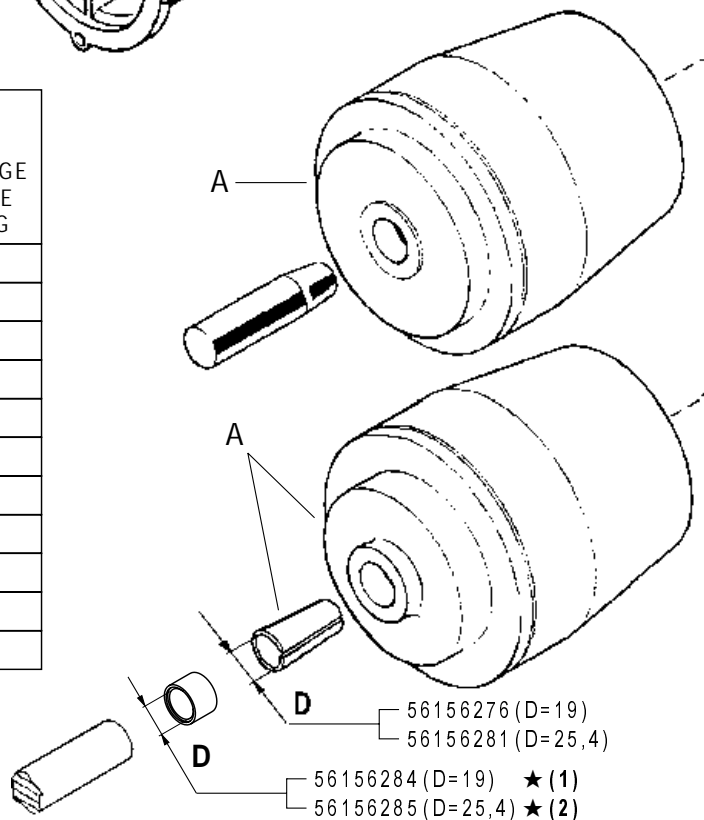

 **NON SMONTARE MAI LA FRIZIONE
NEVER DISASSEMBLE THE CLUTCH
NE DEMONTER JAMAIS L'EMBRAYAGE
NIEMALS DIE KUPPLUNG AUSBAUEN
NO DESMONTAR JAMAS EL EMBRAGUE**

FERRARI

500 serie GRIFON

FRIZIONE A CONO AUTOVENTILANTE

CLUTCH
EMBRAGUE

EMBRAYAGE
KUPPLUNG

DALLA MACCHINA
DE LA MAQUINA
FROM THE MACHINE
AB DER MASCHINE

★ N.

(2) 779519
(1) 779324

D01

11/2006

Rev.
2

ZENNE

Pos.	Code	Q.ty	Description	Notes
31100003	31100003	1	SCREW TE 5/16X7/8	
31100015	31100015	1	SCREW TE 3/8X1	
31211080	31211080	1	NUT M8	
31241080	31241080	1	SELFLOCK NUT M8	
31312083	31312083	1	STUD BOLT M8X46X16X16	
31312088	31312088	1	STUD BOLT M8X40X14X14	
31423084	31423084	1	SPRING WASHER 8,4	
31423105	31423105	1	SPRING WASHER 10,5	
37112173	37112173	1	BEARING	
50956262	50956262	1	CLUTCH LEVER	
52447896	52447896	1	PRESSURE PLATE	
53156150	53156150	1	ENGINE FLANGE	
53247488	53247488	1	ENGINE FLANGE	
55147842	55147842	1	BELLOWS	
55157609	55157609	1	BELLOWS	
56147845	56147845	1	CLUTCH LEVER	
56156276	56156276	1	SLEEVE	
56156281	56156281	1	CENTRING BUSH	
56156284	56156284	1	SPACER	
56156285	56156285	1	SPACER	
59247884	59247884	1	CLUTCH ASSY	
59247924	59247924	1	CLUTCH	
59247971	59247971	1	CLUTCH	
59256255	59256255	1	CLUTCH ASSY	
59256275	59256275	1	CLUTCH ASSY	
59256279	59256279	1	CLUTCH ASSY	
59256280	59256280	1	CLUTCH ASSY	

SERIAL

CLUTCH

CODE REV

D01_2_33546

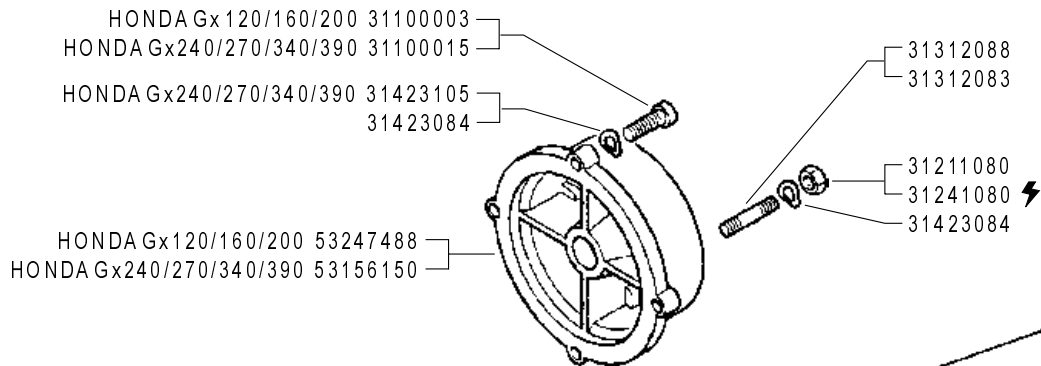

MOTORE ENGINE MOTEUR MOTOR MOTOR	FRIZIONE CLUTCH A EMBRAYAGE EMBRAGUE KUPPLUNG
Acme A220	59247884
Acme ACT 280 - A349 - A360	59247884
Acme ACT 340	59247971
Honda Gx390 - Gx340 D=25,4	59256280
Honda Gx240/270 D=25,4	59256279
Honda Gx120/160/200 D=19	59256275
Lombardini 15LD315/350	59247884
Lombardini 15LD500	59247924
Lombardini LGA 340 ★	59247971
Yanmar L100AE	59247971
Yanmar L70AE	59247884

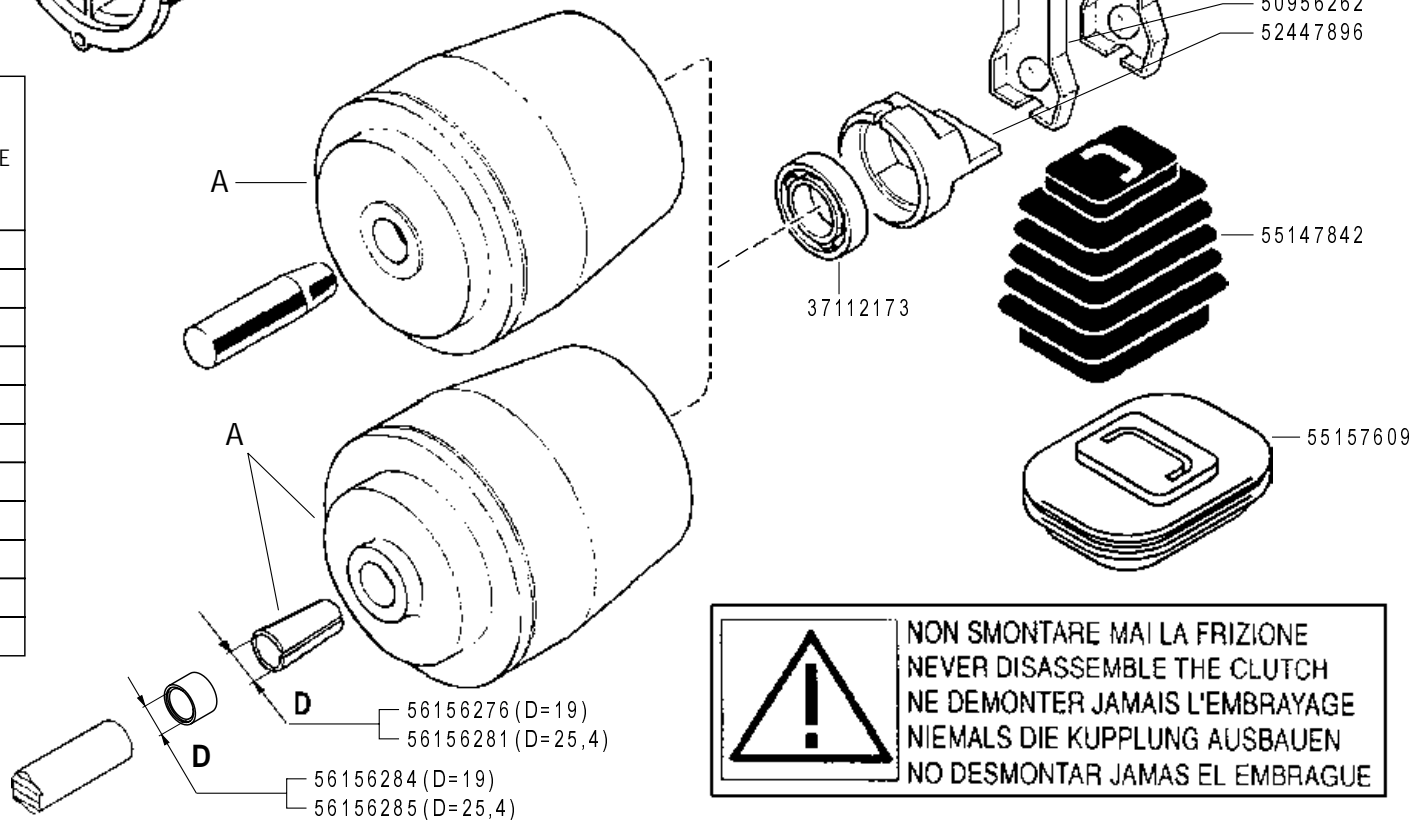

 **NON SMONTARE MAI LA FRIZIONE
NEVER DISASSEMBLE THE CLUTCH
NE DEMONTER JAMAIS L'EMBRAYAGE
NIEMALS DIE KUPPLUNG AUSBAUEN
NO DESMONTAR JAMAS EL EMBRAGUE**

FERRARI

500 serie GRIFON

FRIZIONE A CONO AUTOVENTILANTE

CLUTCH
EMBRAGUE

EMBRAYAGE
KUPPLUNG

DALLA MACCHINA
DE LA MAQUINA
FROM THE MACHINE
AB DER MASCHINE

AGGIORNAMENTO

REVISION

MISE A JOUR

APLAZAMIENTO

ANPASSUNG

★ N.

D01

01/2009

Rev. 3

ZENNE

Pos.	Code	Q.ty	Description	Notes
31100003	31100003	1	SCREW TE 5/16X7/8	
31100015	31100015	1	SCREW TE 3/8X1	
31211080	31211080	1	NUT M8	
31241080	31241080	1	SELFLOCK NUT M8	
31312083	31312083	1	STUD BOLT M8X46X16X16	
31312088	31312088	1	STUD BOLT M8X40X14X14	
31423084	31423084	1	SPRING WASHER 8,4	
31423105	31423105	1	SPRING WASHER 10,5	
37112173	37112173	1	BEARING	
50956262	50956262	1	CLUTCH LEVER	
52447896	52447896	1	PRESSURE PLATE	
53156150	53156150	1	ENGINE FLANGE	
53247488	53247488	1	ENGINE FLANGE	
55147842	55147842	1	BELLOWS	
55157609	55157609	1	BELLOWS	
56147845	56147845	1	CLUTCH LEVER	
56156276	56156276	1	SLEEVE	
56156281	56156281	1	CENTRING BUSH	
56156284	56156284	1	SPACER	
56156285	56156285	1	SPACER	
59247884	59247884	1	CLUTCH ASSY	
59247924	59247924	1	CLUTCH	
59247971	59247971	1	CLUTCH	
59256275	59256275	1	CLUTCH ASSY	
59256279	59256279	1	CLUTCH ASSY	
59256280	59256280	1	CLUTCH ASSY	

SERIAL

CLUTCH

CODE REV

D01_3_59819

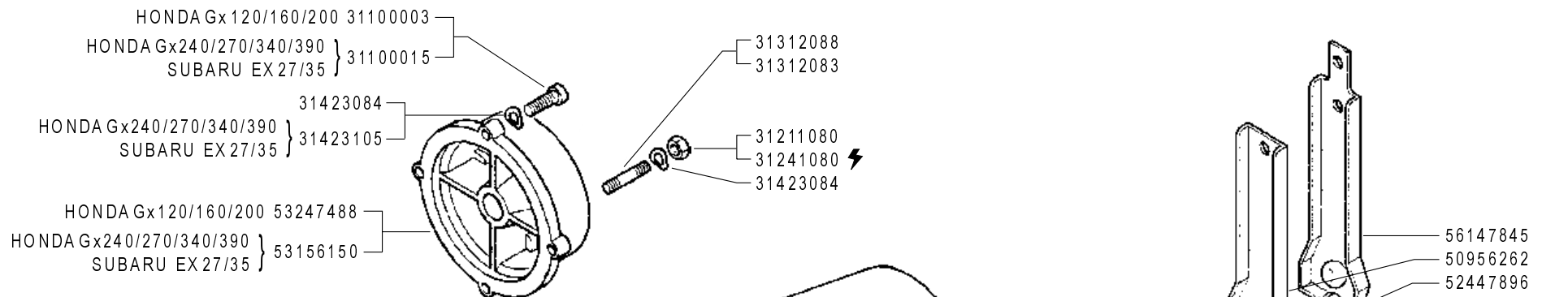

MOTORE ENGINE MOTEUR MOTOR MOTOR	FRIZIONE CLUTCH A EMBRAYAGE EMBRAGUE KUPPLUNG
Acme A220	59247884
Acme ACT 280 - A349 - A360	59247884
Acme ACT 340	59247971
Honda Gx390 - Gx340 D=25,4	59256280
Honda Gx240/270 D=25,4	59256279
Honda Gx120/160/200 D=19	59256275
Lombardini 15LD315/350	59247884
Lombardini 15LD500	59247924
Lombardini LGA 340	59247971
Subaru EX 27 ★	59256279
Subaru EX 35 ★	59256280
Yanmar L100AE	59247971
Yanmar L70AE	59247884

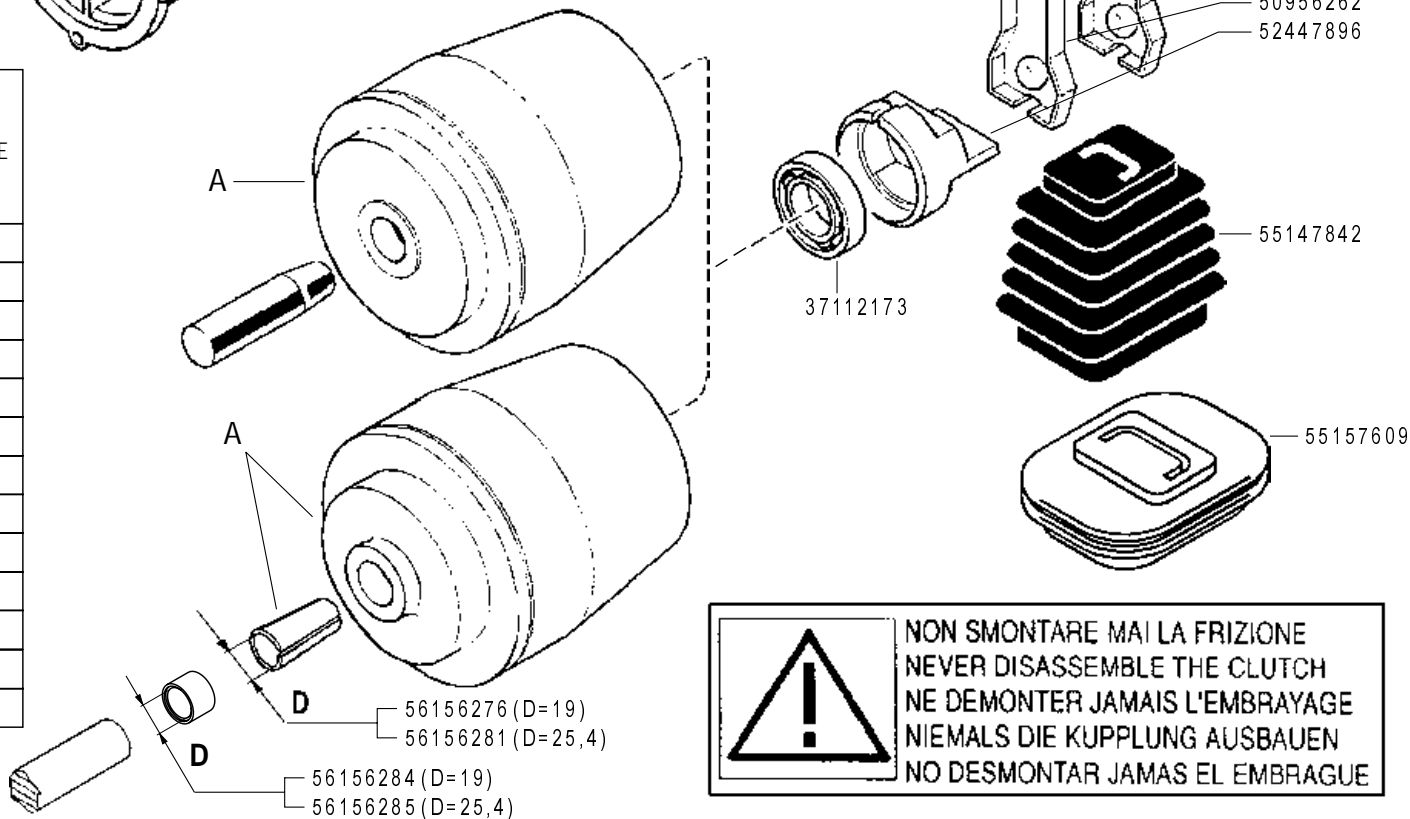

! NON SMONTARE MAI LA FRIZIONE
 NEVER DISASSEMBLE THE CLUTCH
 NE DEMONTER JAMAIS L'EMBRAYAGE
 NIEMALS DIE KUPPLUNG AUSBAUEN
 NO DESMONTAR JAMAS EL EMBRAGUE

FERRARI

500 serie GRIFON

FRIZIONE A CONO AUTOVENTILANTE

CLUTCH
EMBRAGUE

EMBAYAGE
KUPPLUNG

DALLA MACCHINA
DE LA MAQUINA
DE LA MACHINE
FROM THE MACHINE
AB DER MASCHINE

AGGIORNAMENTO
REVISION
MISE A JOUR
APLAZAMIENTO
ANPASSUNG

★ N.

D01

Rev. 4

03/2010

ZENNE

Pos.	Code	Q.ty	Description	Notes
31100003	31100003	1	SCREW TE 5/16X7/8	
31100015	31100015	1	SCREW TE 3/8X1	
31211080	31211080	1	NUT M8	
31241080	31241080	1	SELFLOCK NUT M8	
31312083	31312083	1	STUD BOLT M8X46X16X16	
31312088	31312088	1	STUD BOLT M8X40X14X14	
31423084	31423084	1	SPRING WASHER 8,4	
31423105	31423105	1	SPRING WASHER 10,5	
37112173	37112173	1	BEARING	
50956262	50956262	1	CLUTCH LEVER	
52447896	52447896	1	PRESSURE PLATE	
53156150	53156150	1	ENGINE FLANGE	
53247488	53247488	1	ENGINE FLANGE	
55147842	55147842	1	BELLOWS	
55157609	55157609	1	BELLOWS	
56147845	56147845	1	CLUTCH LEVER	
56156276	56156276	1	SLEEVE	
56156281	56156281	1	CENTRING BUSH	
56156284	56156284	1	SPACER	
56156285	56156285	1	SPACER	
59247884	59247884	1	CLUTCH ASSY	
59247924	59247924	1	CLUTCH	
59247971	59247971	1	CLUTCH	
59256275	59256275	1	CLUTCH ASSY	
59256279	59256279	1	CLUTCH ASSY	
59256280	59256280	1	CLUTCH ASSY	

SERIAL

CLUTCH

CODE REV

D01_4_72864

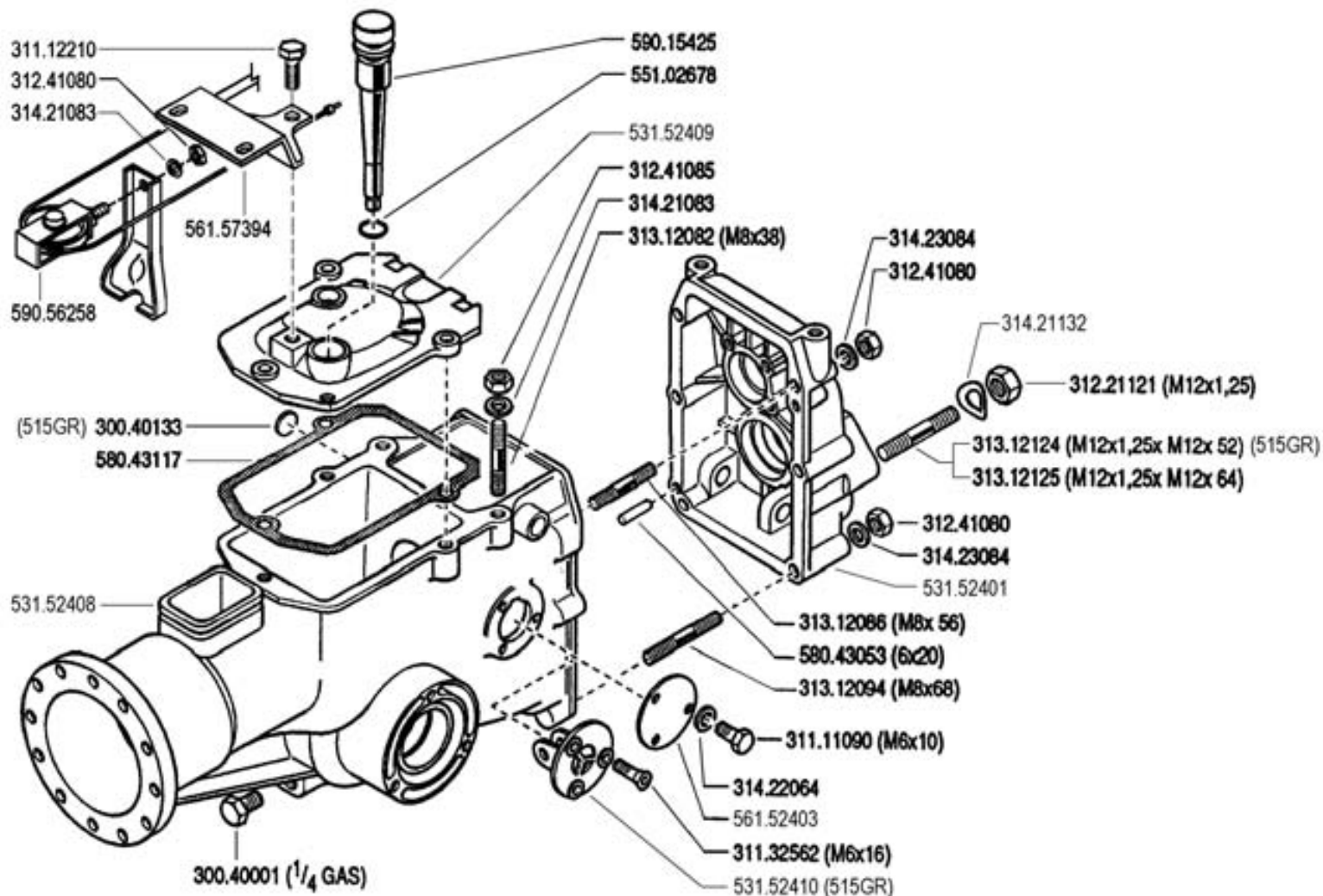

FERRARI

500 serie GRIFON

SCATOLA CAMBIO
(515 GR - 515L GR - 515S GR)

GEARBOX
CAJA DE CAMBIO

BOITE DE VITESSES
WECHSELGETRIEBE

DALLA MACCHINA
DE LA MAQUINA
DE LA MACHINE
FROM THE MACHINE
AB DER MASCHINE

N.

E01 0

09/2004

Rev.

FERRARI

Pos.	Code	Q.ty	Description	Notes
30040001	30040001	1	PLUG	
30040133	30040133	1	PLUG 22 DIN 470	
31111090	31111090	1	SCREW TE M5X10 UNI 5739 8G	
31112210	31112210	1	SCREW TE M10X20 UNI 5739	
31132562	31132562	1	SCREW TSVEI M6X16 UNI 5933	
31221121	31221121	1	NUT M12X1,25	
31241080	31241080	1	SELFLOCK NUT M8	
31241085	31241085	1	SELFLOCK NUT M8 6S	
31312082	31312082	1	STUD BOLT M8X38X14X20	
31312086	31312086	1	STUD BOLT M8X56X20X14	
31312094	31312094	1	STUD BOLT M8X68X14X36	
31312124	31312124	1	STUD BOLT	
31312125	31312125	1	STUD BOLT	
31421083	31421083	1	WASHER	
31421132	31421132	1	WASHER 13X24X2,8	
31422064	31422064	1	SPRING WASHER 6,4	
31423084	31423084	1	SPRING WASHER 8,4	
53152401	53152401	1	REAR COVER	
53152408	53152408	1	BODY	
53152409	53152409	1	COVER	
53152410	53152410	1	GEAR SUPPORT	
55102678	55102678	1	RUBBER RING	
56152403	56152403	1	COVER	
56157394	56157394	1	STOP	
58043053	58043053	1	CYLINDRICAL PLUG	
58043117	58043117	1	COVER GASKET	
59015425	59015425	1	PLUG	
59056258	59056258	1	CLUTCH FORK	

SERIAL

GEARBOX

CODE REV

E01_0_22534

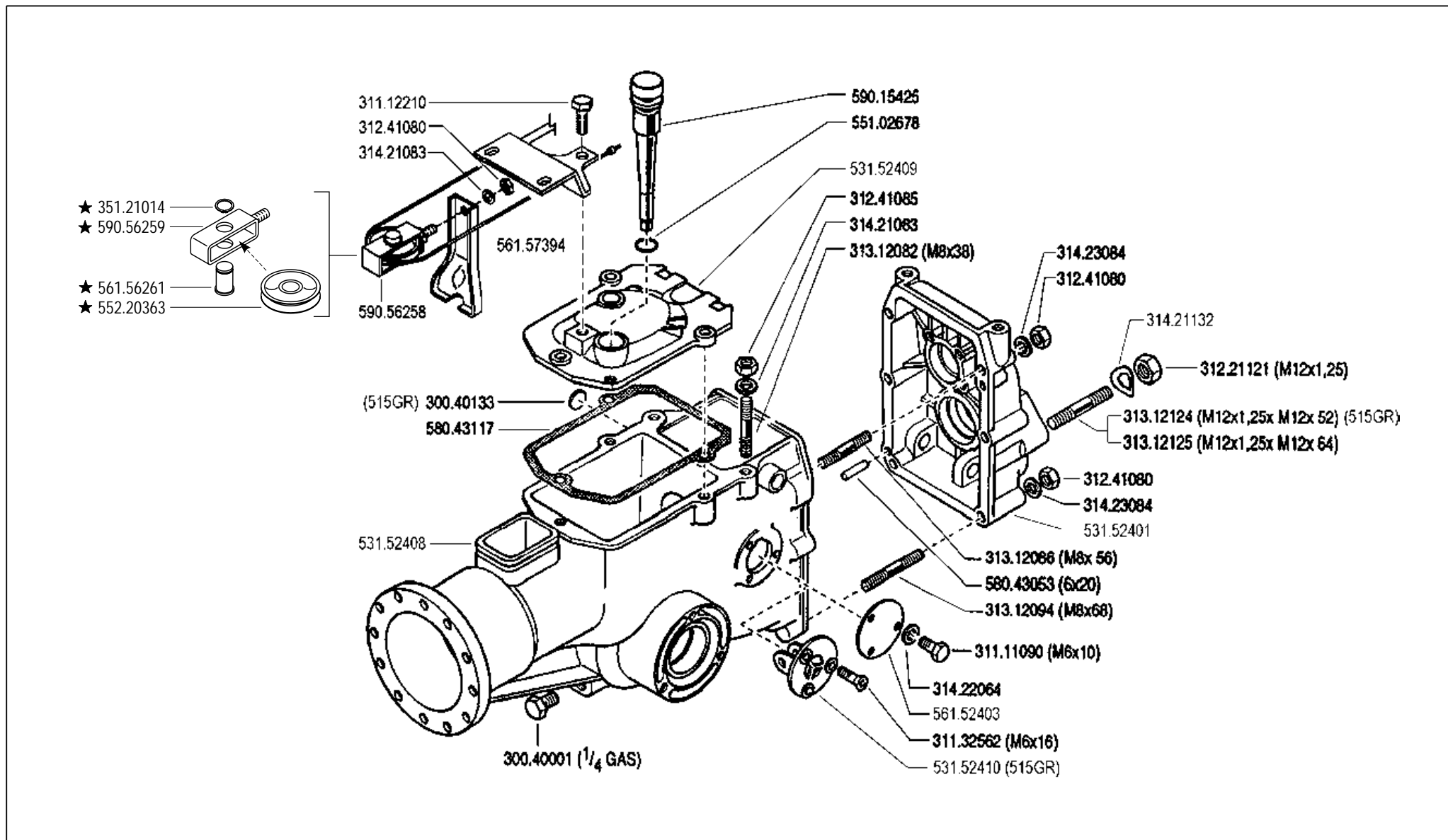

FERRARI

500 serie **GRIFON**

GEARBOX
CAJA DE CAMBIO

SCATOLA CAMBIO
(515 GR - 515L GR - 515S GR)

BOITE DE VITESSES
WECHSELGETRIEBE

DALLA MACCHINA
FROM THE MACHINE
DE LA MACHINE
DE LA MAQUINA
AB DER MASCHINE

AGGIORNAMENTO
APLAZAMIENTO
MISE A JOUR
REVISION
ANPASSUNG

★N.

E01

07/2005

Rev.
1

ZENNE

Pos.	Code	Q.ty	Description	Notes
30040001	30040001	0	PLUG	
30040133	30040133	0	PLUG 22 DIN 470	
31111090	31111090	0	SCREW TE M5X10 UNI 5739 8G	
31112210	31112210	0	SCREW TE M10X20 UNI 5739	
31132562	31132562	0	SCREW TSVEI M6X16 UNI 5933	
31221121	31221121	0	NUT M12X1,25	
31241080	31241080	0	SELFLOCK NUT M8	
31241085	31241085	0	SELFLOCK NUT M8 6S	
31312082	31312082	0	STUD BOLT M8X38X14X20	
31312086	31312086	0	STUD BOLT M8X56X20X14	
31312094	31312094	0	STUD BOLT M8X68X14X36	
31312124	31312124	0	STUD BOLT	
31312125	31312125	0	STUD BOLT	
31421083	31421083	0	WASHER	
31421132	31421132	0	WASHER 13X24X2,8	
31422064	31422064	0	SPRING WASHER 6,4	
31423084	31423084	0	SPRING WASHER 8,4	
35121014	35121014	1	SEEGER RING E 14 DIN 471	
53152401	53152401	0	REAR COVER	
53152408	53152408	0	BODY	
53152409	53152409	0	COVER	
53152410	53152410	0	GEAR SUPPORT	
55102678	55102678	0	RUBBER RING	
55220363	55220363	1	PULLEY	
56152403	56152403	0	COVER	
56156261	56156261	1	PIN	
56157394	56157394	0	STOP	
58043053	58043053	0	CYLINDRICAL PLUG	
58043117	58043117	0	COVER GASKET	
59015425	59015425	0	PLUG	
59056258	59056258	0	CLUTCH FORK	
59056259	59056259	1	CLUTCH FORK	

SERIAL

GEARBOX

CODE REV

E01_1_23274

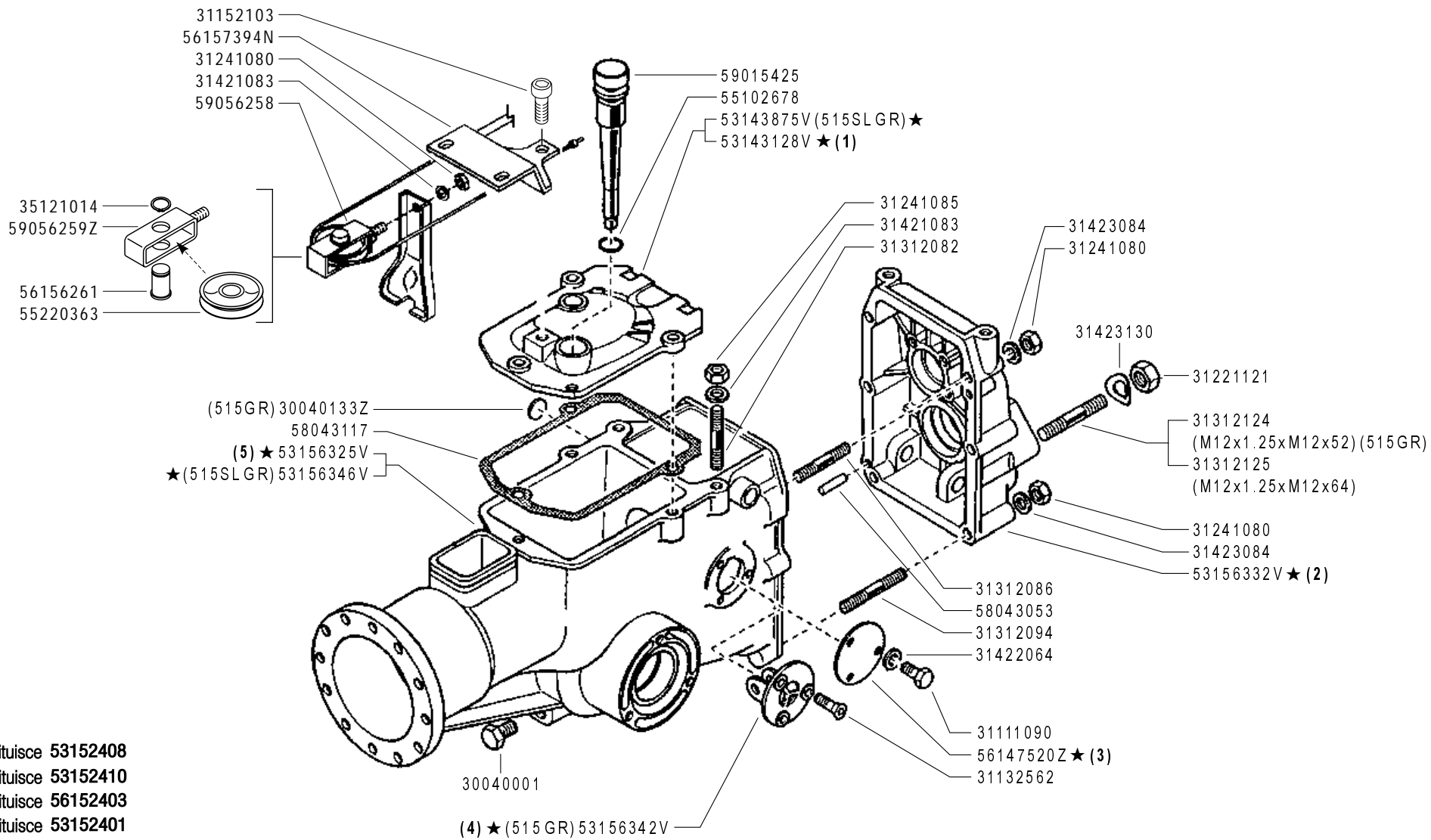

- (5) sostituisce 53152408
- (4) sostituisce 53152410
- (3) sostituisce 56152403
- (2) sostituisce 53152401
- (1) sostituisce 53152409

FERRARI

500 serie GRIFON

SCATOLA CAMBIO
(515GR - 515L GR - 515S GR - 515SL GR ★)
GEARBOX
CAJA DE CAMBIO

BOITE DE VITESSES
WECHSELGETRIEBE

DALLA MACCHINA
DE LA MAQUINA
DE LA MACHINE
FROM THE MACHINE
AB DER MASCHINE

AGGIORNAMENTO
REVISION
MISE A JOUR
APLAZAMIENTO
ANPASSUNG

★ N.

E01

Rev.
2

02/2009

ZENNE

Pos.	Code	Q.ty	Description	Notes
30040001	30040001	1	PLUG	
31111090	31111090	1	SCREW TE M5X10 UNI 5739 8G	
31132562	31132562	1	SCREW TSVEI M6X16 UNI 5933	
31152103	31152103	1	SCREW TCEI M10X25 UNI 5931	
31221121	31221121	1	NUT M12X1,25	
31241080	31241080	1	SELFLOCK NUT M8	
31241085	31241085	1	SELFLOCK NUT M8 6S	
31312082	31312082	1	STUD BOLT M8X38X14X20	
31312086	31312086	1	STUD BOLT M8X56X20X14	
31312094	31312094	1	STUD BOLT M8X68X14X36	
31312124	31312124	1	STUD BOLT	
31312125	31312125	1	STUD BOLT	
31421083	31421083	1	WASHER	
31422064	31422064	1	SPRING WASHER 6,4	
31423084	31423084	1	SPRING WASHER 8,4	
31423130	31423130	1	SPRING WASHER 13	
35121014	35121014	1	SEEGER RING E 14 DIN 471	
55102678	55102678	1	RUBBER RING	
55220363	55220363	1	PULLEY	
56156261	56156261	1	PIN	
58043053	58043053	1	CYLINDRICAL PLUG	
58043117	58043117	1	COVER GASKET	
59015425	59015425	1	PLUG	
59056258	59056258	1	CLUTCH FORK	
30040133	30040133Z	1	PLUG 22 DIN 470	
53143128	53143128V	1	COVER	
53143875	53143875V	1	GEARBOX HOUSING COVER	
53156325	53156325V	1	BODY	
53156332	53156332B	1	REAR COVER	
53156342	53156342V	1	GEAR SUPPORT	
53156346	53156346V	1	BODY	
56147520	56147520Z	1	COVER	
56157394	56157394N	1	STOP	
59056259	59056259Z	1	CLUTCH FORK	

SERIAL

GEARBOX

CODE REV

E01_2_67697

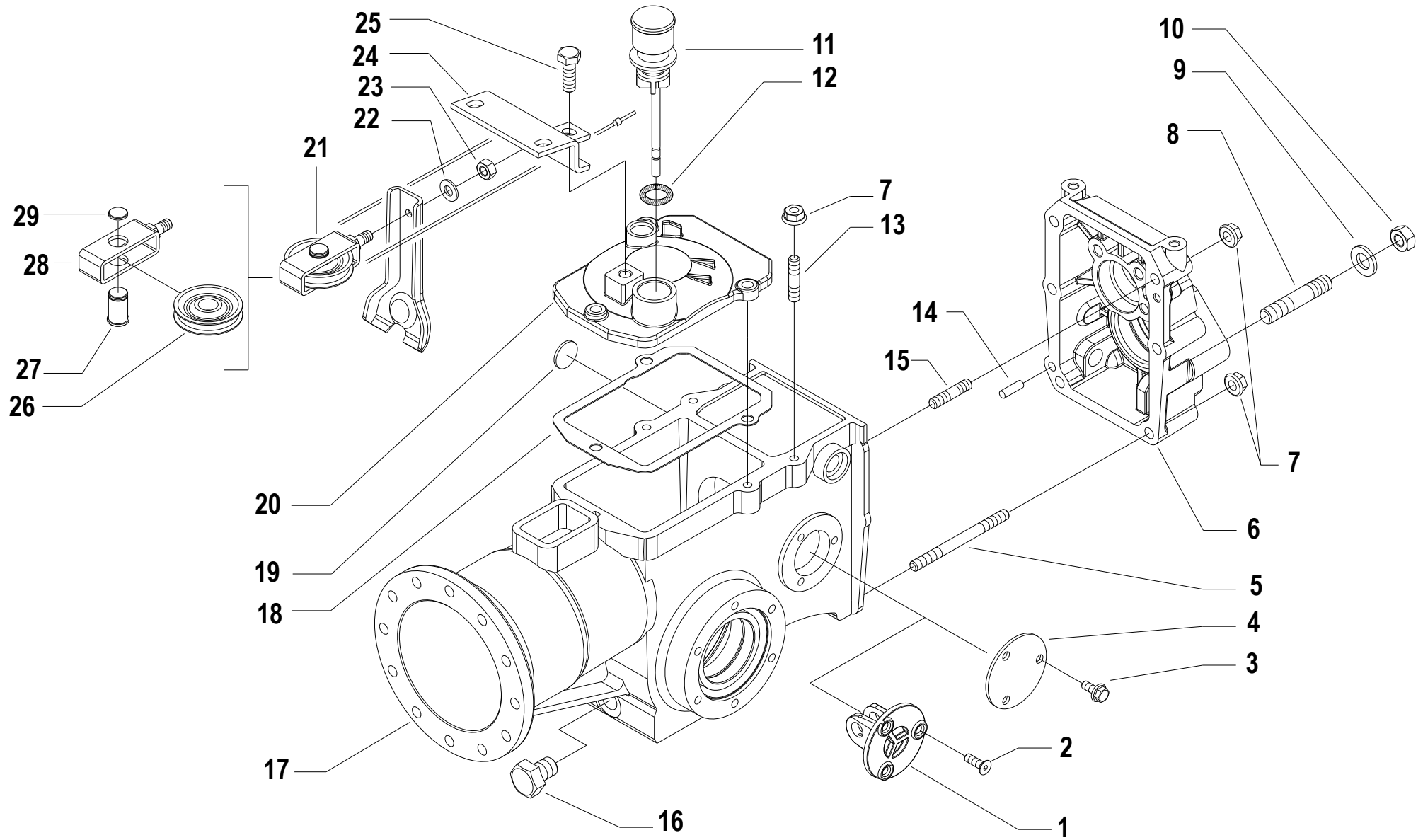

Pos.	Code	Q.ty	Description	Notes
1	53156342V	1	GEAR SUPPORT	
2	31132562	1	SCREW TSVEI M6X16 UNI 5933	
3	31112083	1	SCREW M6X12	
4	56147520Z	1	COVER	
5	31312094	1	STUD BOLT M8X68X14X36	
6	53156332V	1	REAR COVER	
7	31241084	1	SELFLOCK NUT M8 6S	
8	31312124	1	STUD BOLT	For the model 515G
8	31312125	1	STUD BOLT	
9	31421130	1	WASHER	
10	31221121	1	NUT M12X1,25	
11	59015425	1	PLUG	
12	55102678	1	RUBBER RING	
13	31312082	1	STUD BOLT M8X38X14X20	
14	58043053	1	CYLINDRICAL PLUG	
15	31312086	1	STUD BOLT M8X56X20X14	
16	30040001	1	PLUG	
17	53156325V	1	BODY	
17	53156346V	1	BODY	For the model 515SLGR
18	58043117	1	COVER GASKET	
19	30040133Z	1	PLUG 22 DIN 470	For the model 515GR
20	53143128V	1	COVER	
20	53143875V	1	GEARBOX HOUSING COVER	
21	59056258	1	CLUTCH FORK	
22	31421083	1	WASHER	
23	31241080	1	SELFLOCK NUT M8	
24	56157394N	1	STOP	
25	31152103	1	SCREW TCEI M10X25 UNI 5931	
26	55220363	1	PULLEY	
27	56156261	1	PIN	
28	59056259Z	1	CLUTCH FORK	
29	35121014	1	SEEGER RING E 14 DIN 471	

SERIAL

GEARBOX

CODE REV

E.01.02.A0011_03

GEARBOX

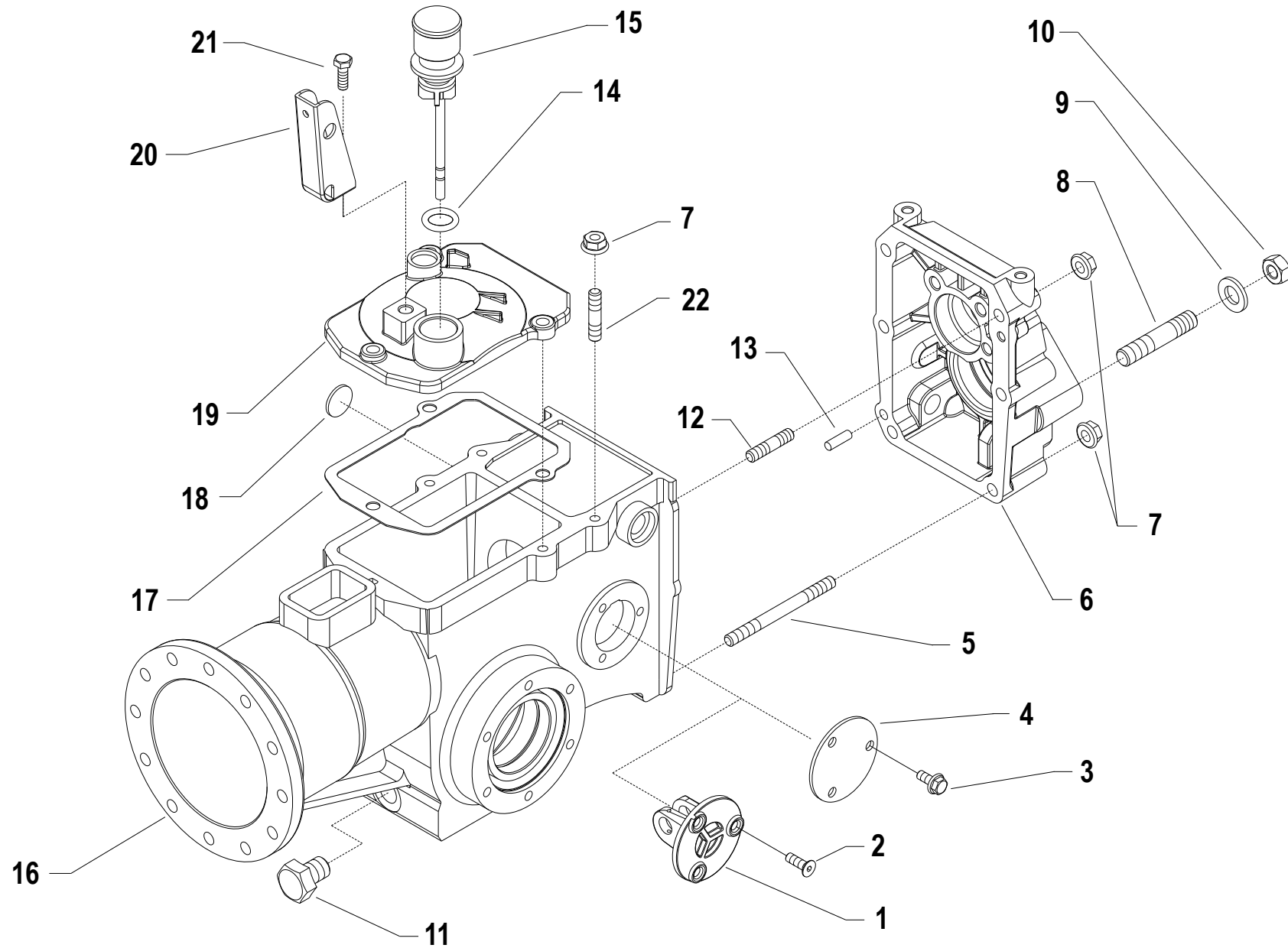

Pos.	Code	Q.ty	Description	Notes
1	53156342V		GEAR SUPPORT	515GR
2	31132562		SCREW TSVEI M6X16 UNI 5933	
3	31112083		SCREW M6X12	
4	56147520Z		COVER	
5	31312094		STUD BOLT M8X68X14X36	
6	53156332V		REAR COVER	
7	31241084		SELFLOCK NUT M8 6S	
8	31312124		STUD BOLT	515GR
8	31312125		STUD BOLT	
9	31421130		WASHER	
10	31221121		NUT M12X1,25	
11	30040001		PLUG	
12	31312086		STUD BOLT M8X56X20X14	
13	58043053		CYLINDRICAL PLUG	
14	55102678		RUBBER RING	
15	59015425		PLUG	
16	53156325V		BODY	
16	53156346V		BODY	
17	58043117		COVER GASKET	
18	30040133Z		PLUG 22 DIN 470	
19	53143128V		COVER	
19	53143875V		GEARBOX HOUSING COVER	515SLGR
20	56147923N		BRACKET	
21	31152103		SCREW TCEI M10X25 UNI 5931	
22	31312082		STUD BOLT M8X38X14X20	

SERIAL
START
953111

GEARBOX

CODE REV

E.01.02.A0011_04

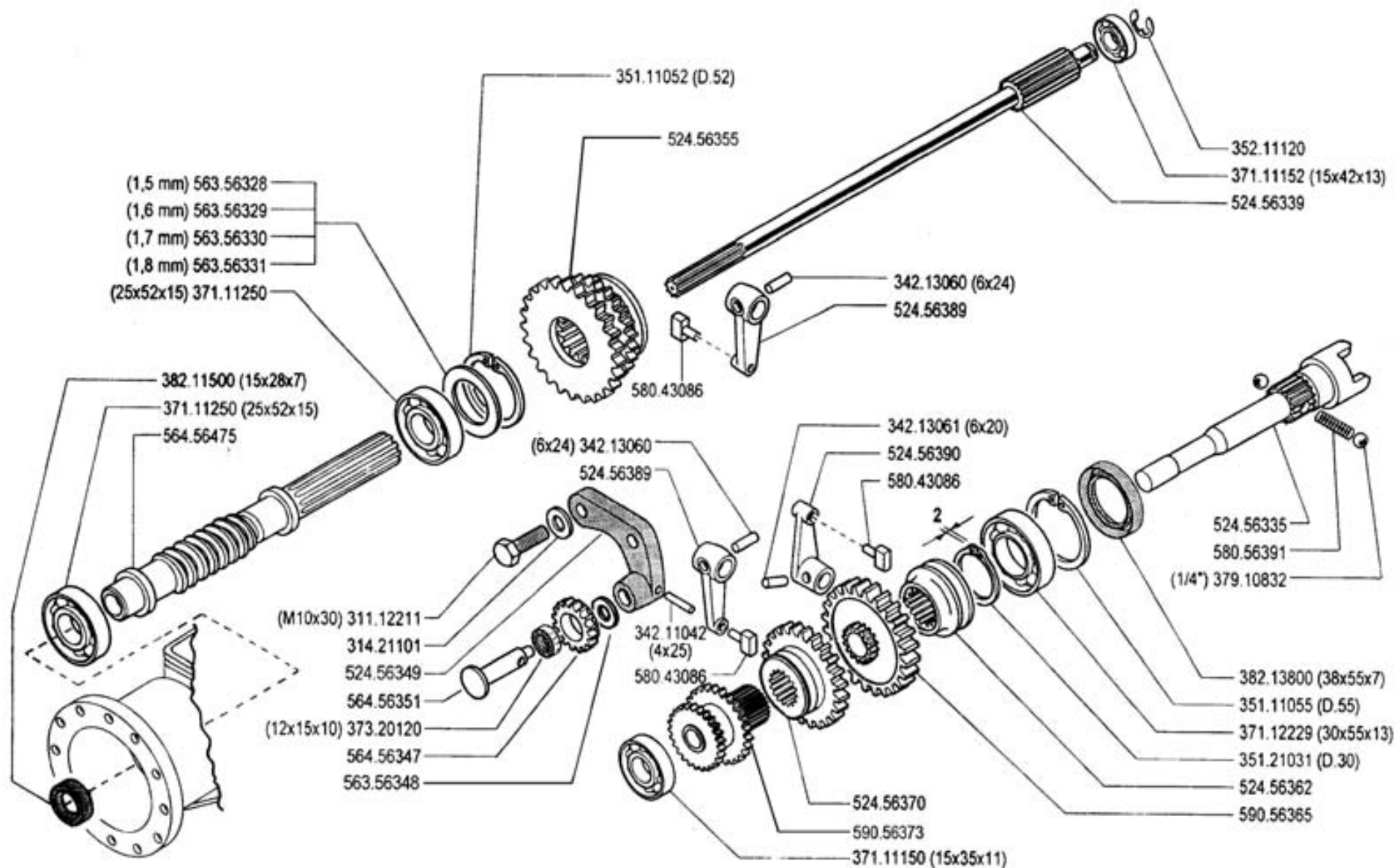

FERRARI

500 serie GRIFON

INGRANAGGI CAMBIO (515L GR - 515S GR)

GEARBOX
CAJA DE CAMBIO

BOITE DE VITESSES
WECHSELGETRIEBE

DALLA MACCHINA
DE LA MAQUINA
DE LA MACHINE
FROM THE MACHINE
AB DER MASCHINE

N.

F02

Rev.
0

09/2004

FITTE

Pos.	Code	Q.ty	Description	Notes
31112211	31112211	1	SCREW TE M10X30 UNI 5739	
31421101	31421101	1	WASHER	
34211042	34211042	1	ROLL PIN	
34213060	34213060	1	ROLL PIN	
34213061	34213061	1	ROLL PIN	
35111052	35111052	1	SEEGER RING I 52 DIN 472	
35111055	35111055	1	SEEGER RING I 55 DIN 472	
35121031	35121031	1	SEEGER RING E 30 UNI 7436	
35211120	35211120	1	SEEGER RING E 12 UNI 7434	
37111150	37111150	1	BEARING	
37111152	37111152	1	BEARING	
37111250	37111250	1	BEARING	
37112229	37112229	1	BEARING	
37320120	37320120	1	ROLLER CAGE 12X15/10	
37910832	37910832	1	BALL 1/4	
38211500	38211500	1	OIL SEAL 15X28X7	
38213800	38213800	1	OIL SEAL 38X55X7	
52456335	52456335	1	PTO SHAFT	
52456339	52456339	1	SHAFT	
52456349	52456349	1	GEAR SUPPORT	
52456355	52456355	1	SLIDER	
52456362	52456362	1	COUPLING	
52456370	52456370	1	SLIDER	
52456389	52456389	1	LEVER	
52456390	52456390	1	LEVER	
56356328	56356328	1	ADJUSTING RING SP=1,5	
56356329	56356329	1	ADJUSTING RING SP=1,6	
56356330	56356330	1	ADJUSTING RING SP=1,7	
56356331	56356331	1	ADJUSTING RING SP=1,8	
56356348	56356348	1	ADJUSTING RING	
56456347	56456347	1	GEAR	
56456351	56456351	1	GEAR PIN	
56456475	56456475	1	SCREW	
58043086	58043086	1	SHOE	

SERIAL

GEARBOX

CODE REV

F02_0_22647

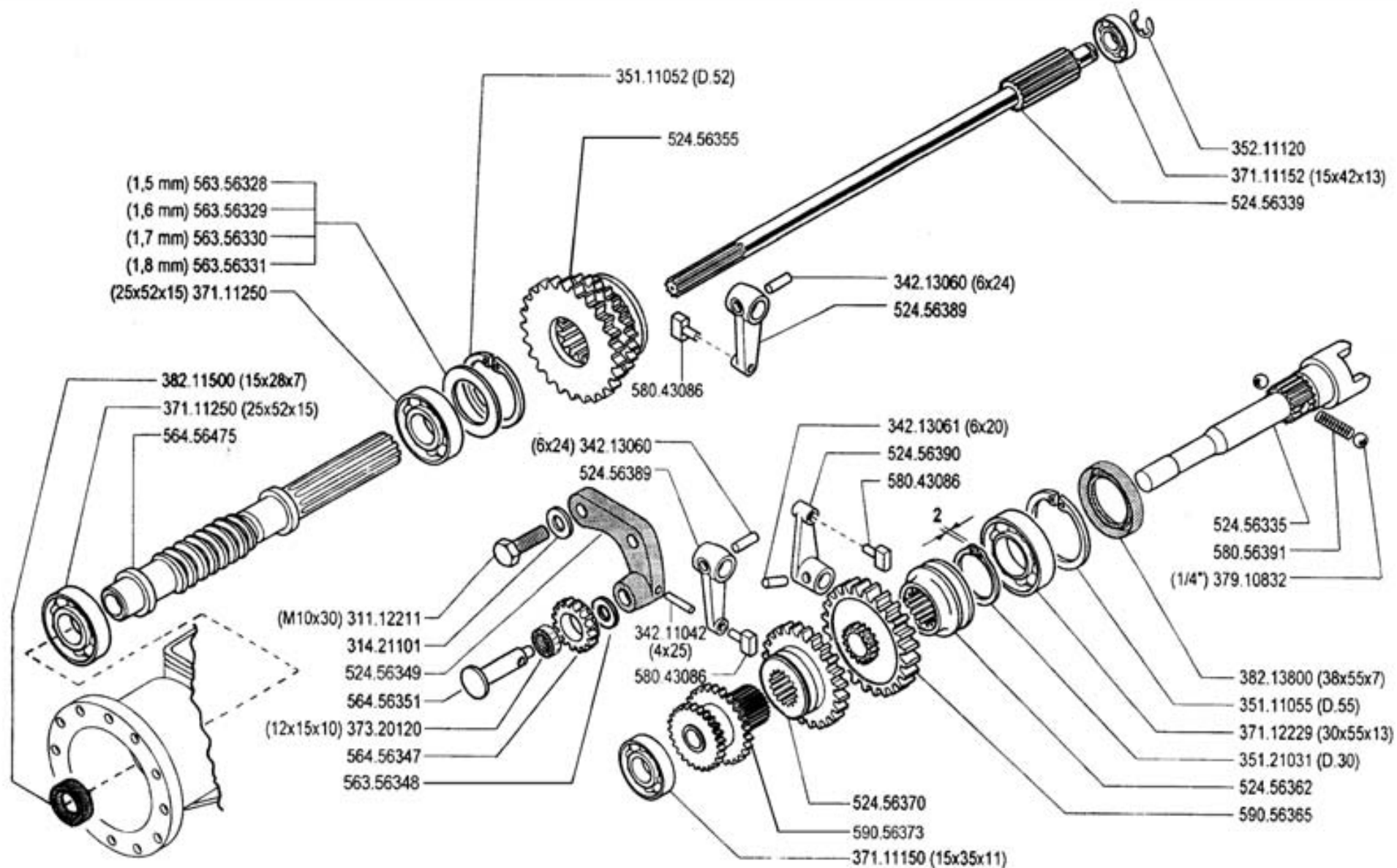

FERRARI

500 serie GRIFON

INGRANAGGI CAMBIO (515L GR - 515S GR)

GEARBOX
CAJA DE CAMBIO

BOITE DE VITESSES
WECHSELGETRIEBE

DALLA MACCHINA
DE LA MAQUINA
DE LA MACHINE
FROM THE MACHINE
AB DER MASCHINE

N.

F02

Rev.

0

09/2004

72786

Pos.	Code	Q.ty	Description	Notes
58056391	58056391	1	SPRING	
59056365	59056365	1	PTO GEAR	
59056373	59056373	1	DOUBLE GEAR	

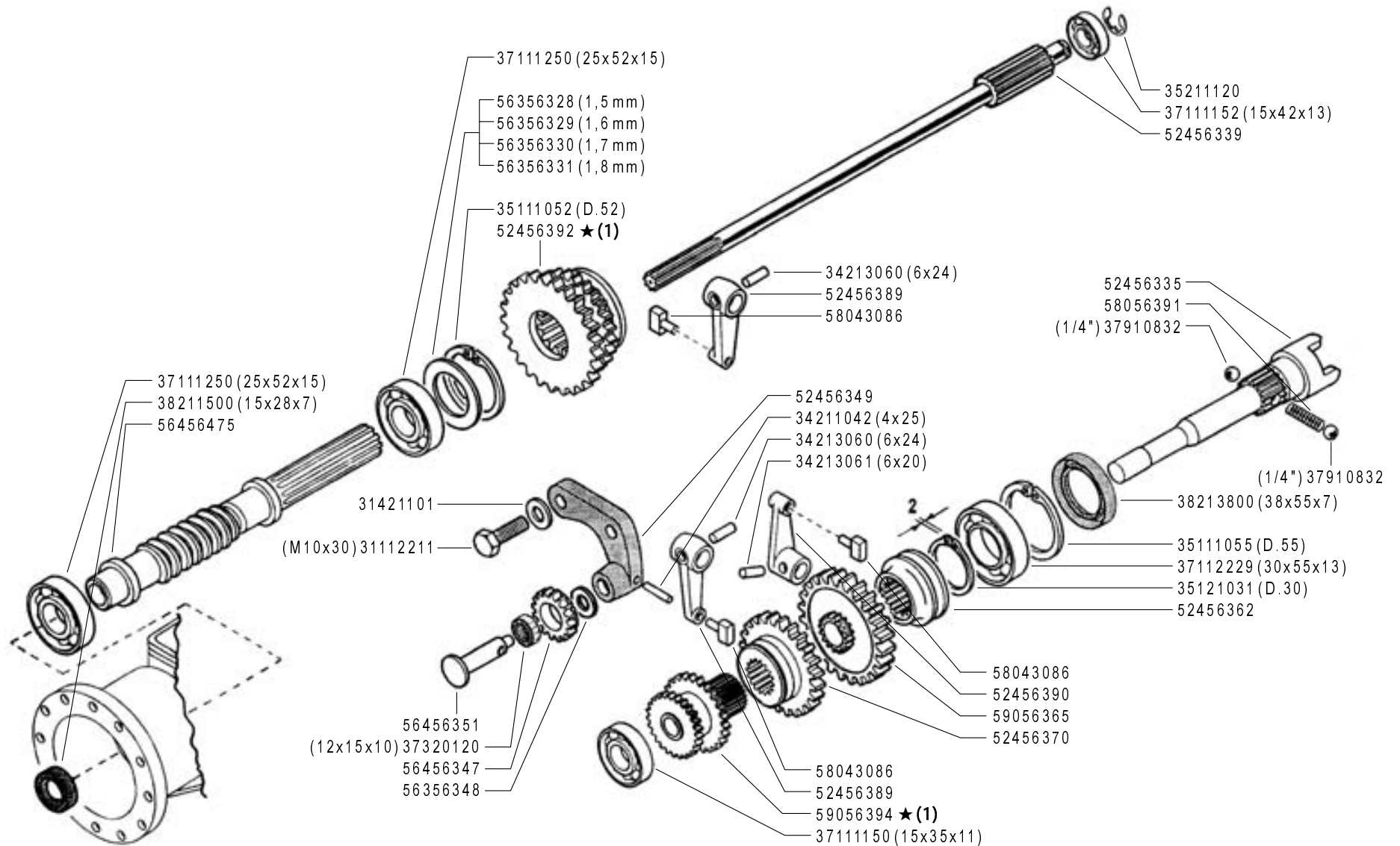

(1) sostituisce (52456355 + 59056373)

FERRARI

500 serie GRIFON

INGRANAGGI CAMBIO (515L GR - 515S GR)

GEARBOX
CAJA DE CAMBIO

BOITE DE VITESSES
WECHSELGETRIEBE

DALLA MACCHINA
DE LA MAQUINA
DE LA MACHINE
FROM THE MACHINE
AB DER MASCHINE

★ N.

809850

F02

03/2008

Rev.
1

ZENNE

Pos.	Code	Q.ty	Description	Notes
31112211	31112211	1	SCREW TE M10X30 UNI 5739	
31421101	31421101	1	WASHER	
34211042	34211042	1	ROLL PIN	
34213060	34213060	1	ROLL PIN	
34213061	34213061	1	ROLL PIN	
35111052	35111052	1	SEEGER RING I 52 DIN 472	
35111055	35111055	1	SEEGER RING I 55 DIN 472	
35121031	35121031	1	SEEGER RING E 30 UNI 7436	
35211120	35211120	1	SEEGER RING E 12 UNI 7434	
37111150	37111150	1	BEARING	
37111152	37111152	1	BEARING	
37111250	37111250	1	BEARING	
37112229	37112229	1	BEARING	
37320120	37320120	1	ROLLER CAGE 12X15/10	
37910832	37910832	1	BALL 1/4	
38211500	38211500	1	OIL SEAL 15X28X7	
38213800	38213800	1	OIL SEAL 38X55X7	
52456335	52456335	1	PTO SHAFT	
52456339	52456339	1	SHAFT	
52456349	52456349	1	GEAR SUPPORT	
52456362	52456362	1	COUPLING	
52456370	52456370	1	SLIDER	
52456389	52456389	1	LEVER	
52456390	52456390	1	LEVER	
52456392	52456392	1	SLIDER	
56356328	56356328	1	ADJUSTING RING SP=1,5	
56356329	56356329	1	ADJUSTING RING SP=1,6	
56356330	56356330	1	ADJUSTING RING SP=1,7	
56356331	56356331	1	ADJUSTING RING SP=1,8	
56356348	56356348	1	ADJUSTING RING	
56456347	56456347	1	GEAR	
56456351	56456351	1	GEAR PIN	
56456475	56456475	1	SCREW	
58043086	58043086	1	SHOE	

SERIAL
START
809850

GEARBOX

CODE REV
F02_1_59847

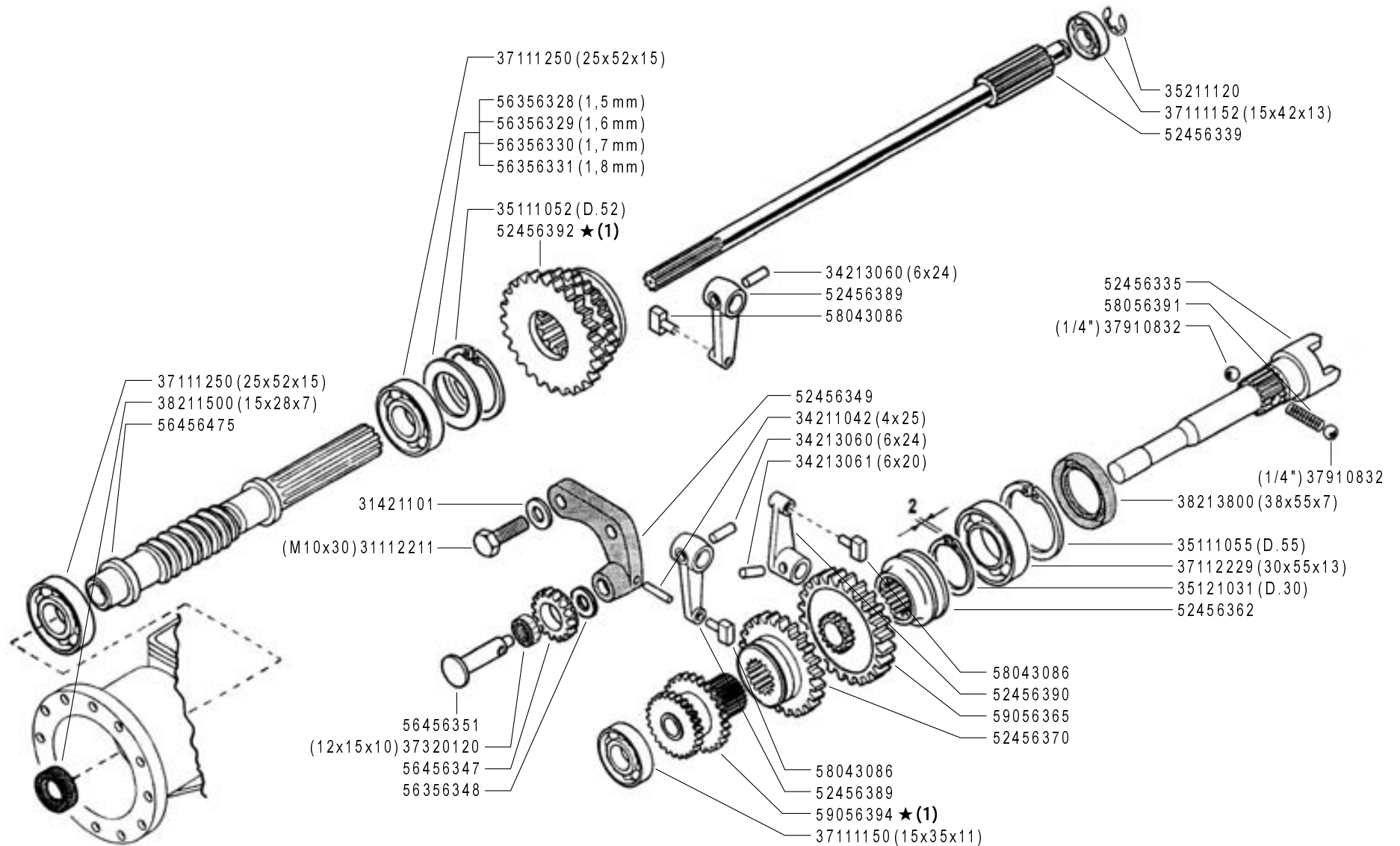

(1) sostituisce (52456355 + 59056373)

FERRARI

500 serie GRIFON

INGRANAGGI CAMBIO (515L GR - 515S GR)

GEARBOX
CAJA DE CAMBIO

BOITE DE VITESSES
WECHSELGETRIEBE

DALLA MACCHINA
DE LA MAQUINA
DE LA MACHINE
FROM THE MACHINE
AB DER MASCHINE

★ N.

809850

F02

03/2008

Rev.
1

ZENNE

Pos.	Code	Q.ty	Description	Notes
58056391	58056391	1	SPRING	
59056365	59056365	1	PTO GEAR	
59056394	59056394	1	DOUBLE GEAR	

SERIAL
START
809850

GEARBOX

CODE REV
F02_1_59847

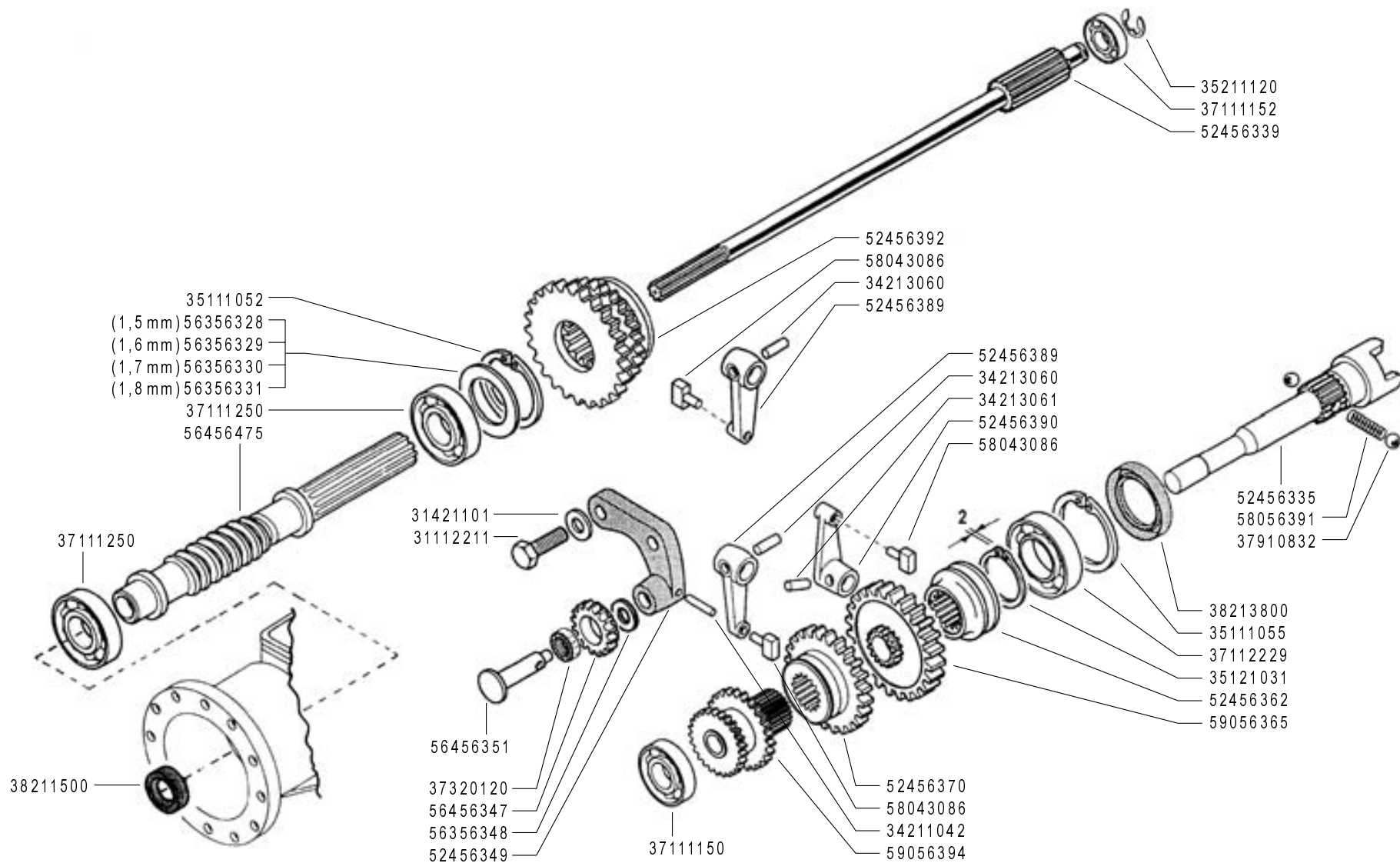

FERRARI

500 serie **GRIFON**

**INGRANAGGI CAMBIO
(515L GR - 515S GR - 515SL GR ★)**

GEARS
ENGRANAJES

ENGRANAGES
ZÄHNRÄDER

DALLA MACCHINA
DE LA MAQUINA
DE LA MACHINE
FROM THE MACHINE
AB DER MASCHINE

★N.

AGGIORNAMENTO
REVISION
MISE A JOUR
APLAZAMIENTO
ANPASSUNG

F02

02/2009

Rev.
2

ZENNE

Pos.	Code	Q.ty	Description	Notes
31112211	31112211	1	SCREW TE M10X30 UNI 5739	
31421101	31421101	1	WASHER	
34211042	34211042	1	ROLL PIN	
34213060	34213060	1	ROLL PIN	
34213061	34213061	1	ROLL PIN	
35111052	35111052	1	SEEGER RING I 52 DIN 472	
35111055	35111055	1	SEEGER RING I 55 DIN 472	
35121031	35121031	1	SEEGER RING E 30 UNI 7436	
35211120	35211120	1	SEEGER RING E 12 UNI 7434	
37111150	37111150	1	BEARING	
37111152	37111152	1	BEARING	
37111250	37111250	1	BEARING	
37112229	37112229	1	BEARING	
37320120	37320120	1	ROLLER CAGE 12X15/10	
37910832	37910832	1	BALL 1/4	
38211500	38211500	1	OIL SEAL 15X28X7	
38213800	38213800	1	OIL SEAL 38X55X7	
52456335	52456335	1	PTO SHAFT	
52456339	52456339	1	SHAFT	
52456349	52456349	1	GEAR SUPPORT	
52456362	52456362	1	COUPLING	
52456370	52456370	1	SLIDER	
52456389	52456389	1	LEVER	
52456390	52456390	1	LEVER	
52456392	52456392	1	SLIDER	
56356328	56356328	1	ADJUSTING RING SP=1,5	
56356329	56356329	1	ADJUSTING RING SP=1,6	
56356330	56356330	1	ADJUSTING RING SP=1,7	
56356331	56356331	1	ADJUSTING RING SP=1,8	
56356348	56356348	1	ADJUSTING RING	
56456347	56456347	1	GEAR	
56456351	56456351	1	GEAR PIN	
56456475	56456475	1	SCREW	
58043086	58043086	1	SHOE	

SERIAL

GEARS

CODE REV

F02_2_67738

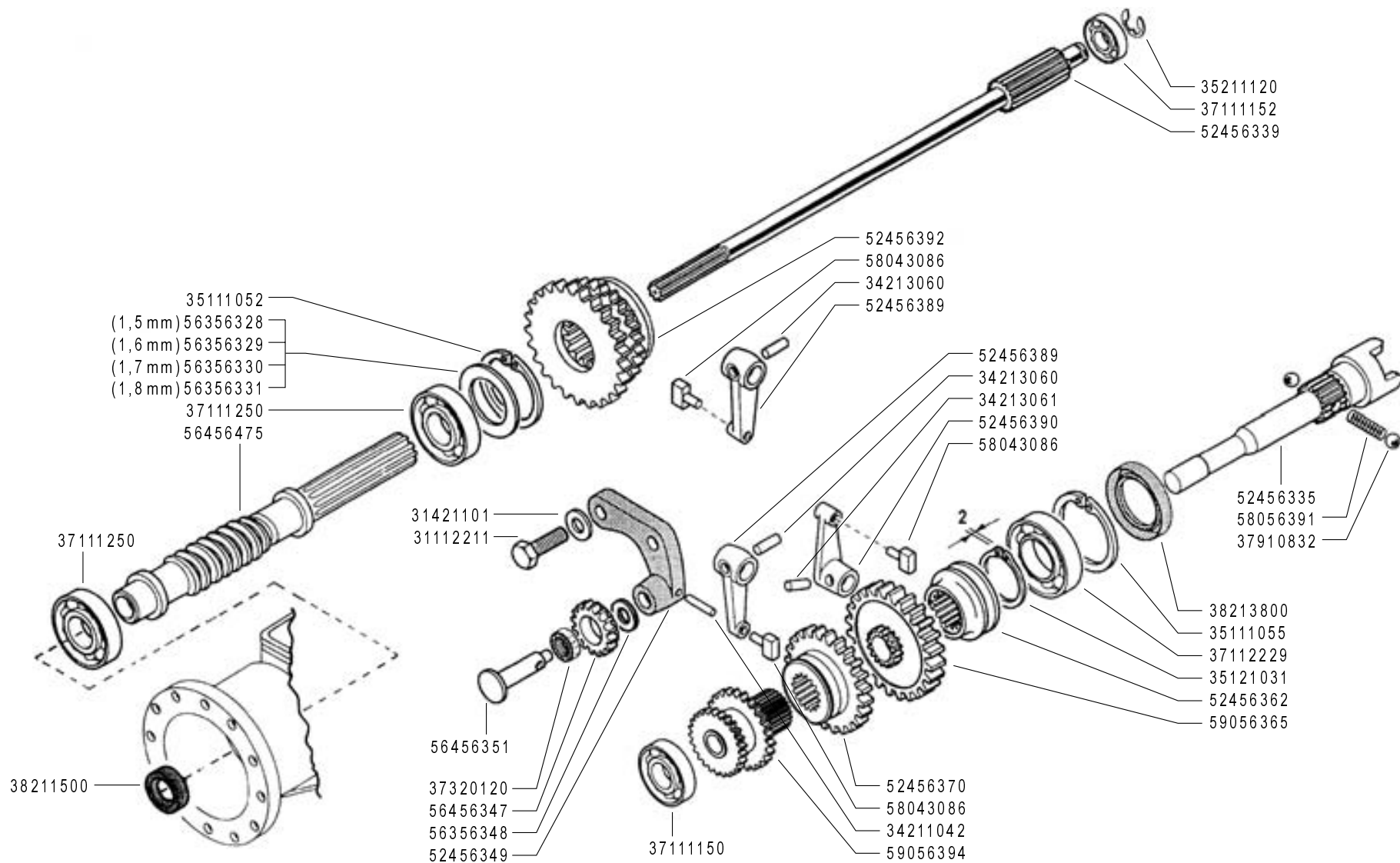

FERRARI

500 serie GRIFON

INGRANAGGI CAMBIO
(515L GR - 515S GR - 515SL GR ★)

GEARS
ENGRANAJES

ENGRANAGES
ZÄHNÄDER

DALLA MACCHINA
DE LA MAQUINA
DE LA MACHINE
FROM THE MACHINE
AB DER MASCHINE

★ N.

AGGIORNAMENTO
REVISION
MISE A JOUR
APLAZAMIENTO
ANPASSUNG

F02

02/2009

Rev.
2

ZENNE

Pos.	Code	Q.ty	Description	Notes
58056391	58056391	1	SPRING	
59056365	59056365	1	PTO GEAR	
59056394	59056394	1	DOUBLE GEAR	

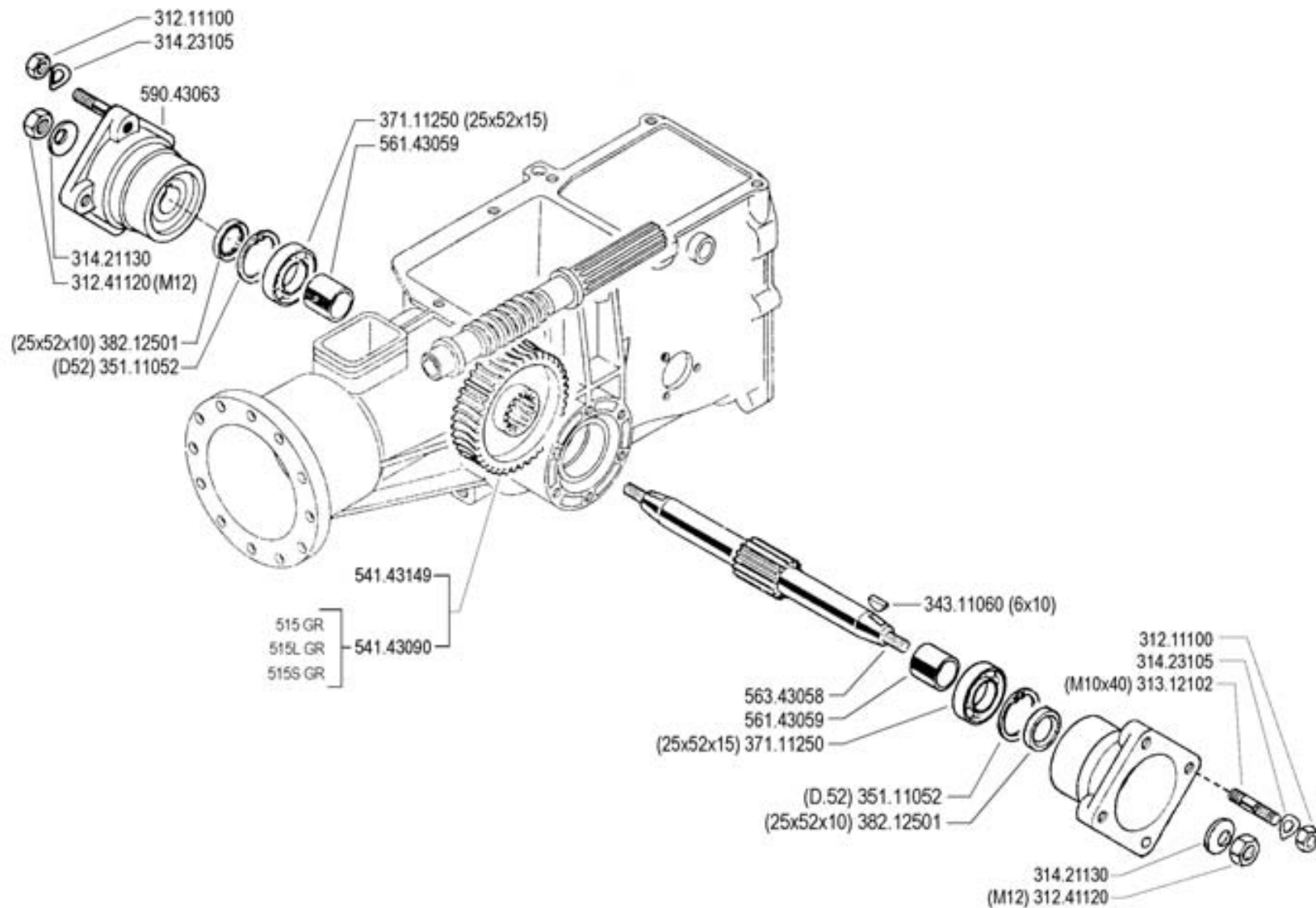

FERRARI

500 serie GRIFON

**ASSE RUOTE
(515 GR - 515L GR - 515S GR - 520 GR)**

WHEEL AXLE
EJE RUEDAS

ESSIEU ROUES
RADACHSE

DALLA MACCHINA
DE LA MAQUINA
DE LA MACHINE
FROM THE MACHINE
AB DER MASCHINE

N.

G01 0

09/2004

Rev.

ZENE

Pos.	Code	Q.ty	Description	Notes
31211100	31211100	1	NUT M10	
31241120	31241120	1	SELFLOCK NUT M12	
31312102	31312102	1	STUD BOLT M10X40X24X12	
31421130	31421130	1	WASHER	
31423105	31423105	1	SPRING WASHER 10,5	
34311060	34311060	1	KEY 6X10 UNI 6606	
35111052	35111052	1	SEEGER RING I 52 DIN 472	
37111250	37111250	1	BEARING	
38212501	38212501	1	OIL SEAL 25X52X10	
54143090	54143090	1	CROWN WHEEL	
54143149	54143149	1	CROWN WHEEL	
56143059	56143059	1	SPACER	
56343058	56343058	1	AXLE SHAFT	
59043063	59043063	1	WHEEL HUB	

GEARS

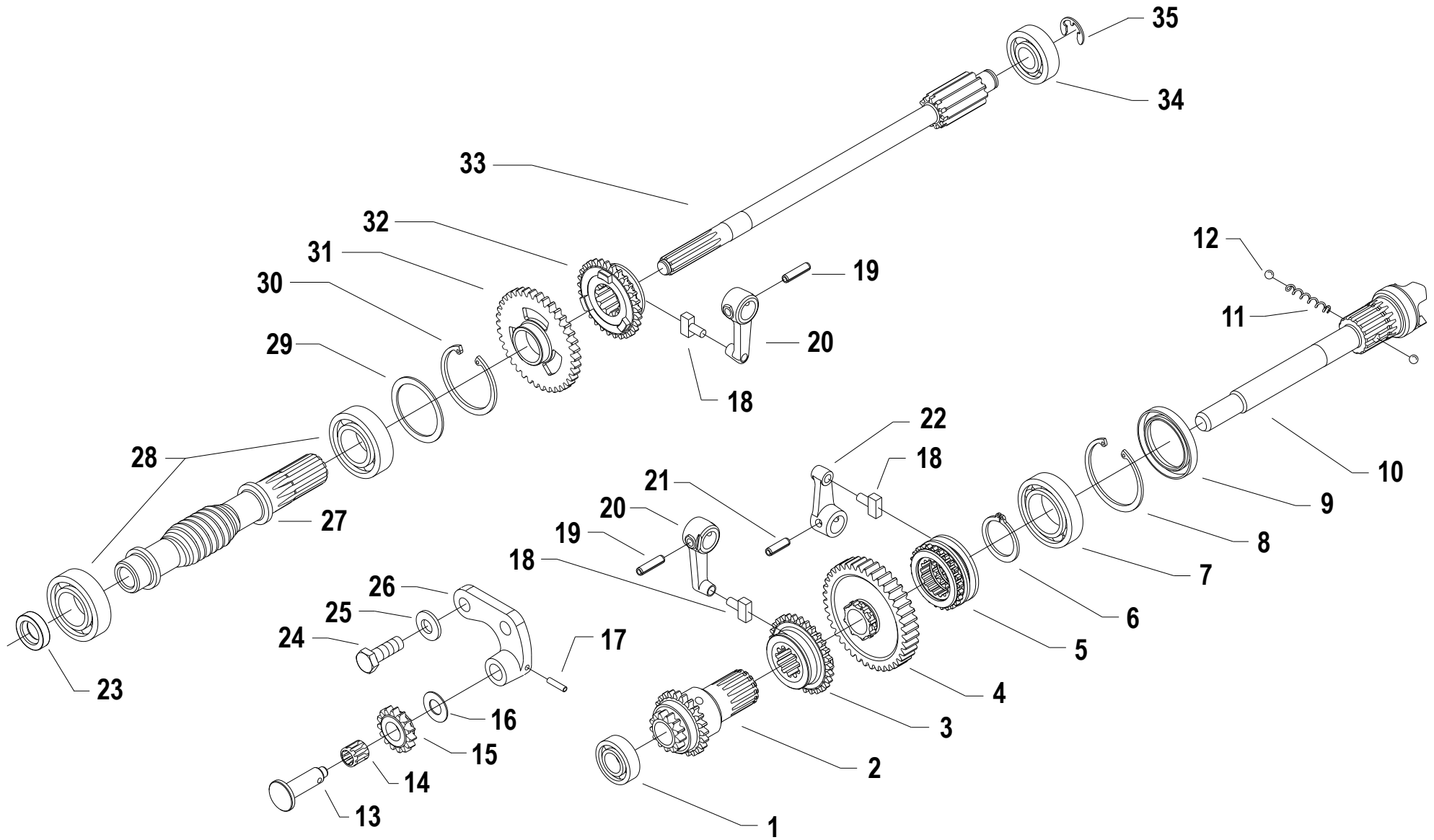

Pos.	Code	Q.ty	Description	Notes
1	37111150		BEARING	
2	59056384		DOUBLE GEAR	
3	52456370		SLIDER	
4	59056707		PTO GEAR	Replaces 59056365 + 52456362
5	52456706		PTO COUPLING	Replaces 59056365 + 52456362
6	35121031		SEEGER RING E 30 UNI 7436	
7	37112229		BEARING	
8	35111055		SEEGER RING I 55 DIN 472	
9	38213800		OIL SEAL 38X55X7	
10	52456335		PTO SHAFT	
11	58056391		SPRING	
12	37910832		BALL 1/4	
13	56456736		PERNO INGRANAGGIO OZIOSO	Replaces 56456351
14	37320120		ROLLER CAGE 12X15/10	
15	56456347		GEAR	
16	56356348		ADJUSTING RING	
17	34211042		ROLL PIN	
18	58043086		SHOE	
19	34213060		ROLL PIN	
20	52456389		LEVER	
21	34213061		ROLL PIN	
22	52456390		LEVER	
23	38211500		OIL SEAL 15X28X7	
24	31112211		SCREW TE M10X30 UNI 5739	
25	31421101		WASHER	
26	52456349		GEAR SUPPORT	
27	56456475		SCREW	
28	37111255		BEARING	
29	56356328		ADJUSTING RING SP=1,5	
29	56356329		ADJUSTING RING SP=1,6	
29	56356330		ADJUSTING RING SP=1,7	
29	56356331		ADJUSTING RING SP=1,8	
30	35111052		SEEGER RING I 52 DIN 472	
31	52456354		GEAR	

SERIAL
START
937702

GEARS

CODE REV

F.02.02.A0011_03

GEARS

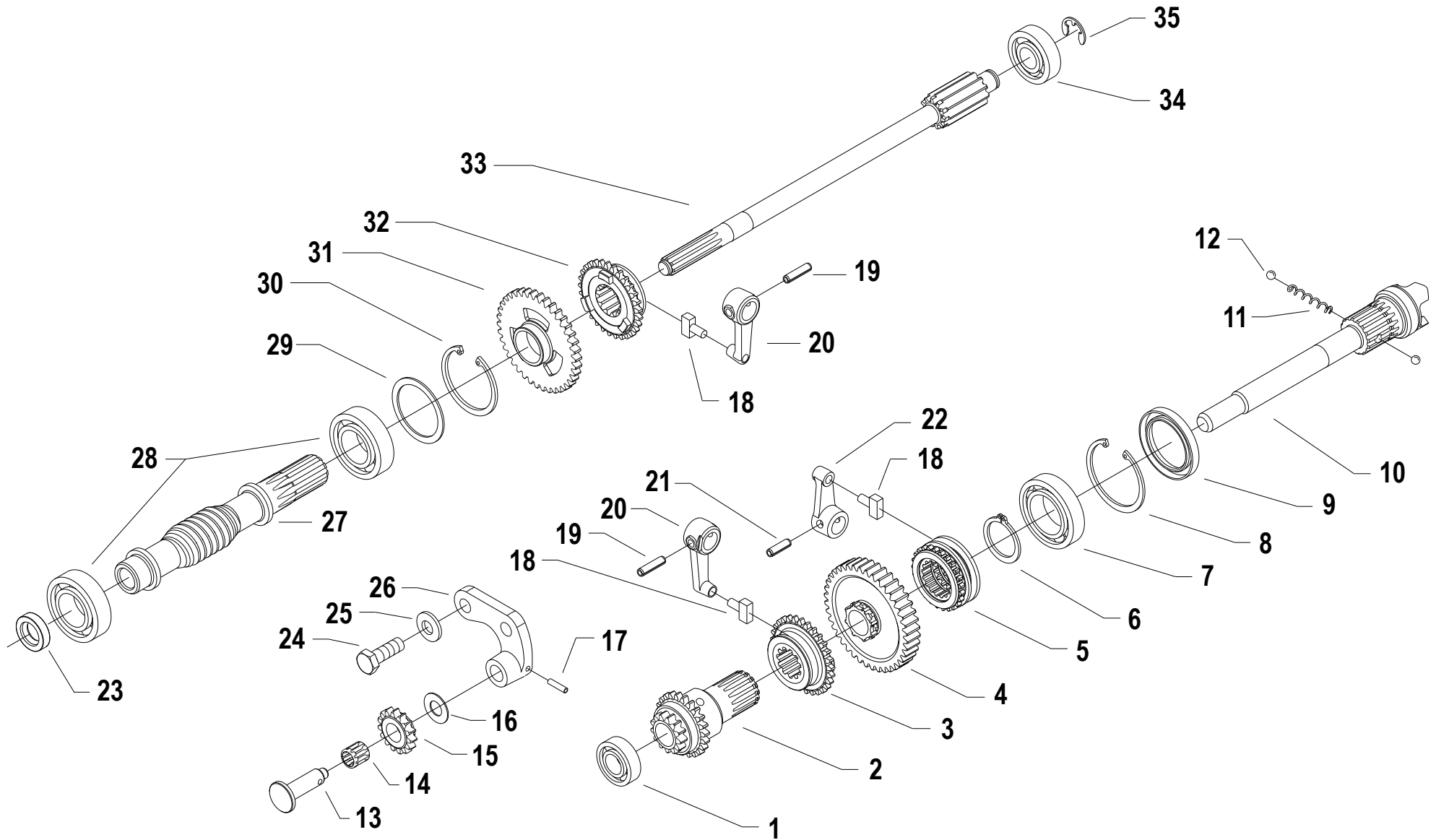

Pos.	Code	Q.ty	Description	Notes
32	52456361		SLIDER	
33	52456339		SHAFT	
34	37111152		BEARING	
35	35211120		SEEGER RING E 12 UNI 7434	

SERIAL
START
937702

GEARS

CODE REV
F.02.02.A0011_03

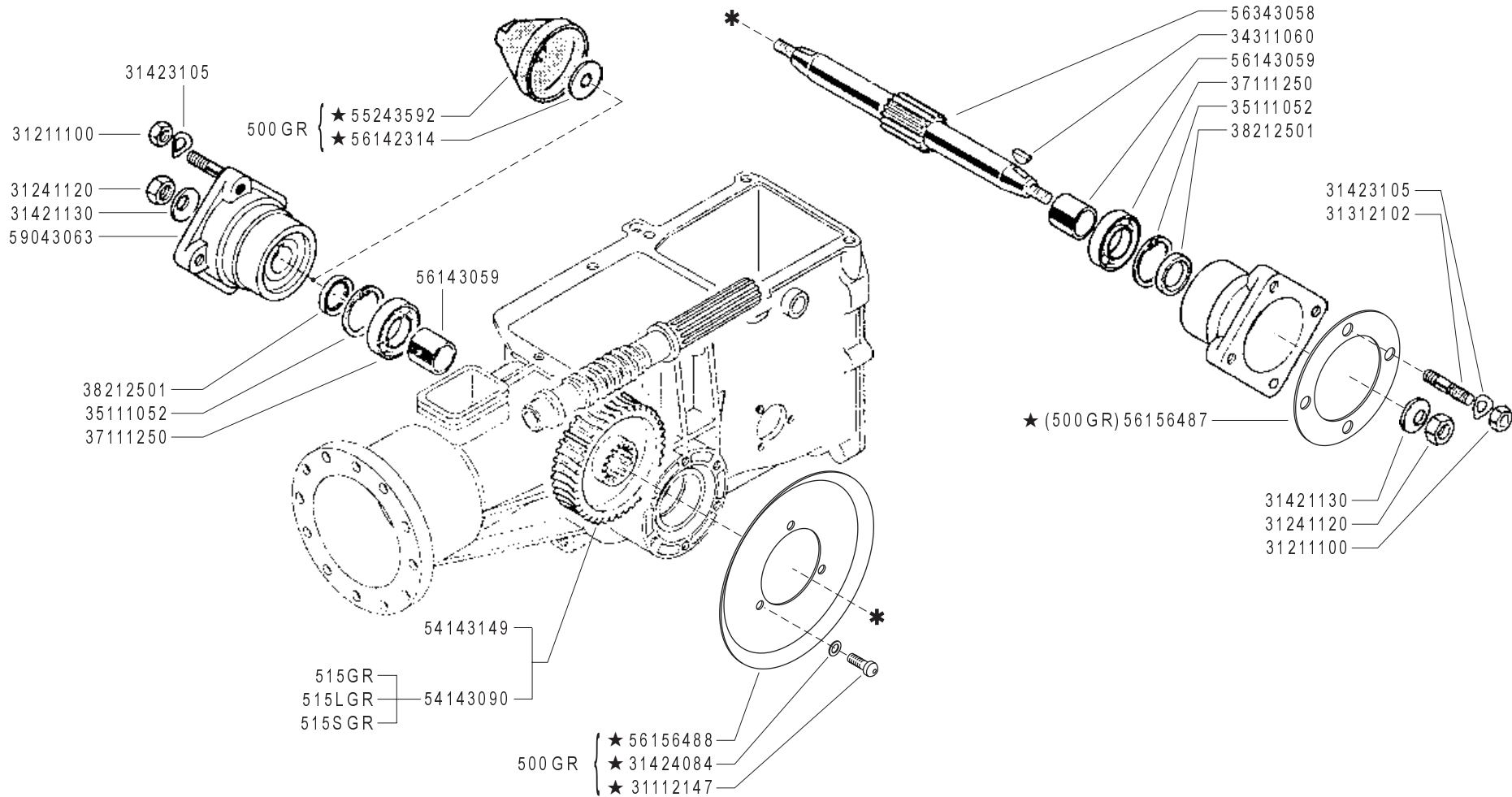

FERRARI

500 serie **GRIFON**

ASSE RUOTE
 (500 GR ★ - 515 GR - 515L GR - 515S GR - 520 GR)
 WHEEL AXLE
 EJE RUEDAS
 ESSIEU ROUES
 RADACHSE

DALLA MACCHINA
 DE LA MAQUINA
 DE LA MACHINE
 FROM THE MACHINE
 AB DER MASCHINE

★ N.

AGGIORNAMENTO
REVISION
MISE A JOUR
APLAZAMIENTO
ANPASSUNG

G01

Rev.
1

06/2006

ZENNE

Pos.	Code	Q.ty	Description	Notes
31112147	31112147	1	SCREW TE M8X18 UNI 5739 8G	
31211100	31211100	1	NUT M10	
31241120	31241120	1	SELFLOCK NUT M12	
31312102	31312102	1	STUD BOLT M10X40X24X12	
31421130	31421130	1	WASHER	
31423105	31423105	1	SPRING WASHER 10,5	
31424084	31424084	1	SPRING WASHER 8,4	
34311060	34311060	1	KEY 6X10 UNI 6606	
35111052	35111052	1	SEEGER RING I 52 DIN 472	
37111250	37111250	1	BEARING	
38212501	38212501	1	OIL SEAL 25X52X10	
54143090	54143090	1	CROWN WHEEL	
54143149	54143149	1	CROWN WHEEL	
55243592	55243592	1	CAP	
56142314	56142314	1	WASHER 12,5x34/4	
56143059	56143059	1	SPACER	
56156487	56156487	1	SPACER	
56156488	56156488	1	GUARD	
56343058	56343058	1	AXLE SHAFT	
59043063	59043063	1	WHEEL HUB	

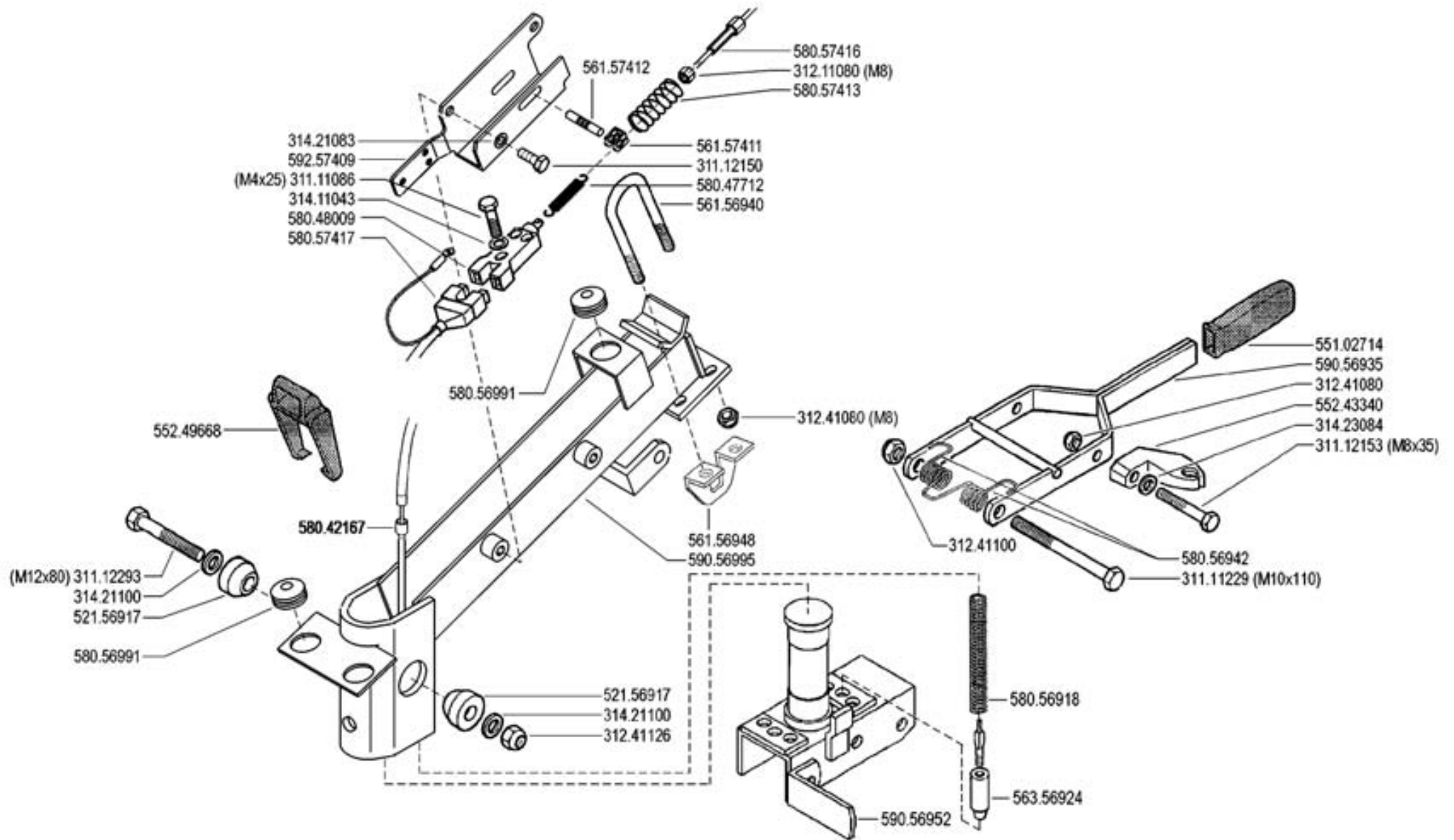

FERRARI

500 serie GRIFON

PIANTONE (515 GR - 515L GR - 515S GR)

STEERING COLUMN
COLUMNNA

PLANTON
LENKSÄULE

DALLA MACCHINA
DE LA MAQUINA
DE LA MACHINE
FROM THE MACHINE
AB DER MASCHINE

N.

H01

Rev.
0

09/2004

ZITONE

Pos.	Code	Q.ty	Description	Notes
31111086	31111086	1	SCREW TE M4X25 UNI 5739 8G	
31111229	31111229	1	SCREW TE M10X110 UNI 5737 8G	
31112150	31112150	1	SCREW TE M8X20 UNI 5739 8G	
31112153	31112153	1	SCREW TE M8X35 UNI 5739 8G	
31112293	31112293	1	SCREW TE M12X80 UNI 5737	
31211080	31211080	1	NUT M8	
31241080	31241080	1	SELFLOCK NUT M8	
31241100	31241100	1	SELFLOCK NUT M10 6S	
31241126	31241126	1	SELFLOCK NUT M12	
31411043	31411043	1	WASHER 4,3X9	
31421083	31421083	1	WASHER	
31421100	31421100	1	CUP SPRING	
31423084	31423084	1	SPRING WASHER 8,4	
52156917	52156917	1	WEDGE	
55102714	55102714	1	KNOB	
55243340	55243340	1	SUPPORT	
55249668	55249668	1	PASSING	
56156940	56156940	1	U BOLT	
56156948	56156948	1	STOP	
56157411	56157411	1	FORK	
56157412	56157412	1	PIN	
56356924	56356924	1	FERRULE	
58042167	58042167	1	SHEATH TERMINAL	
58047712	58047712	1	SPRING	
58048009	58048009	1	SWITCH	
58056918	58056918	1	SPRING	
58056942	58056942	1	SPRING	
58056991	58056991	1	CABLE GLAND	
58057413	58057413	1	RETAINING SPRING	
58057416	58057416	1	LINE AND SHEATH	
58057417	58057417	1	WIRING	
59056935	59056935	1	LEVER	
59056952	59056952	1	SUPPORT	
59056995	59056995	1	COLUMN	

SERIAL

STEERING COLUMN

CODE REV

H01_0_22844

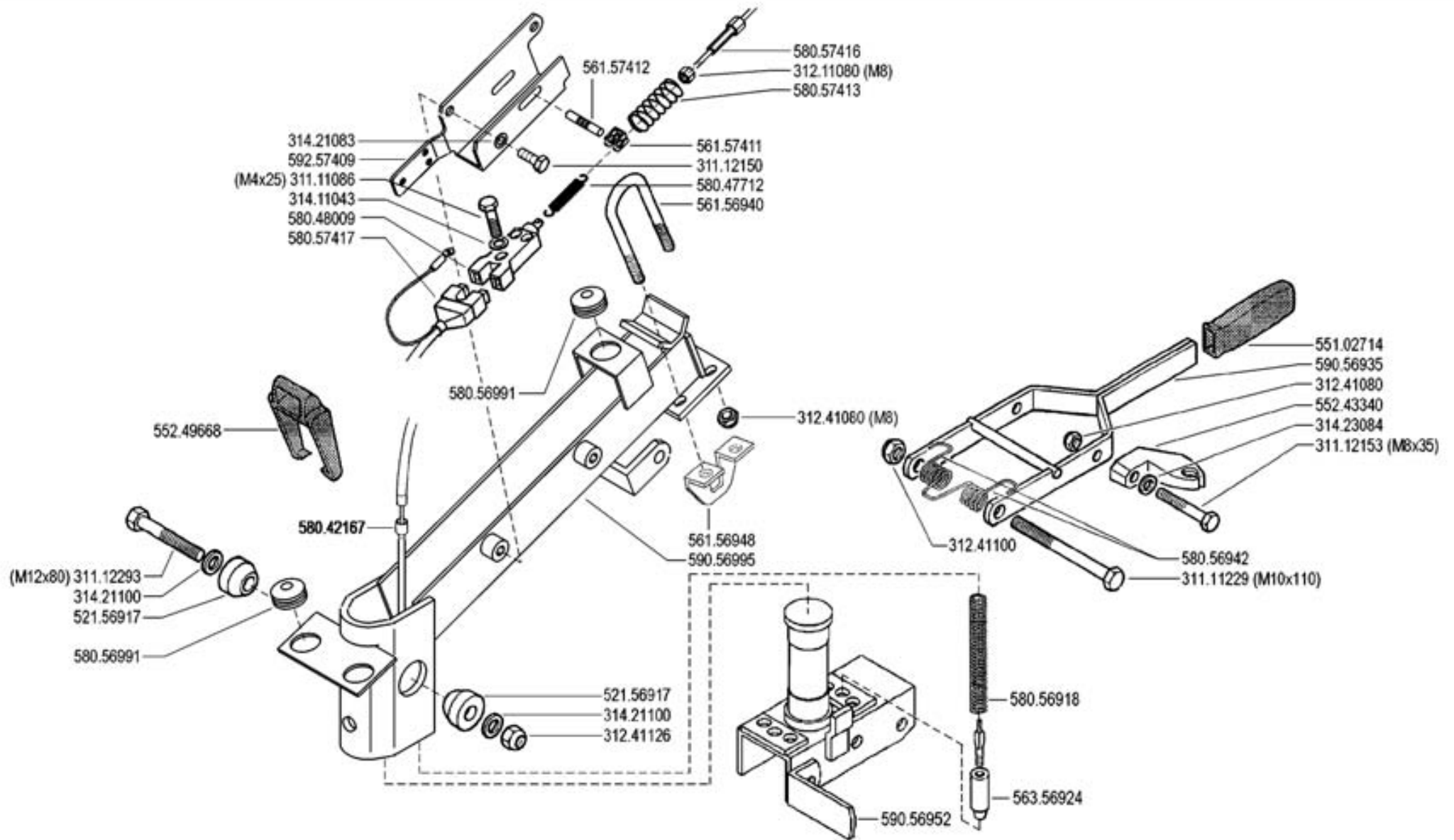

FERRARI

500 serie GRIFON

PIANTONE (515 GR - 515L GR - 515S GR)

STEERING COLUMN
COLUMNNA

PLANTON
LENKSÄULE

DALLA MACCHINA
DE LA MAQUINA
DE LA MACHINE
FROM THE MACHINE
AB DER MASCHINE

N.

H01

Rev.
0

09/2004

ZITONE

Pos.	Code	Q.ty	Description	Notes
59257409	59257409	1	SUPPORT	

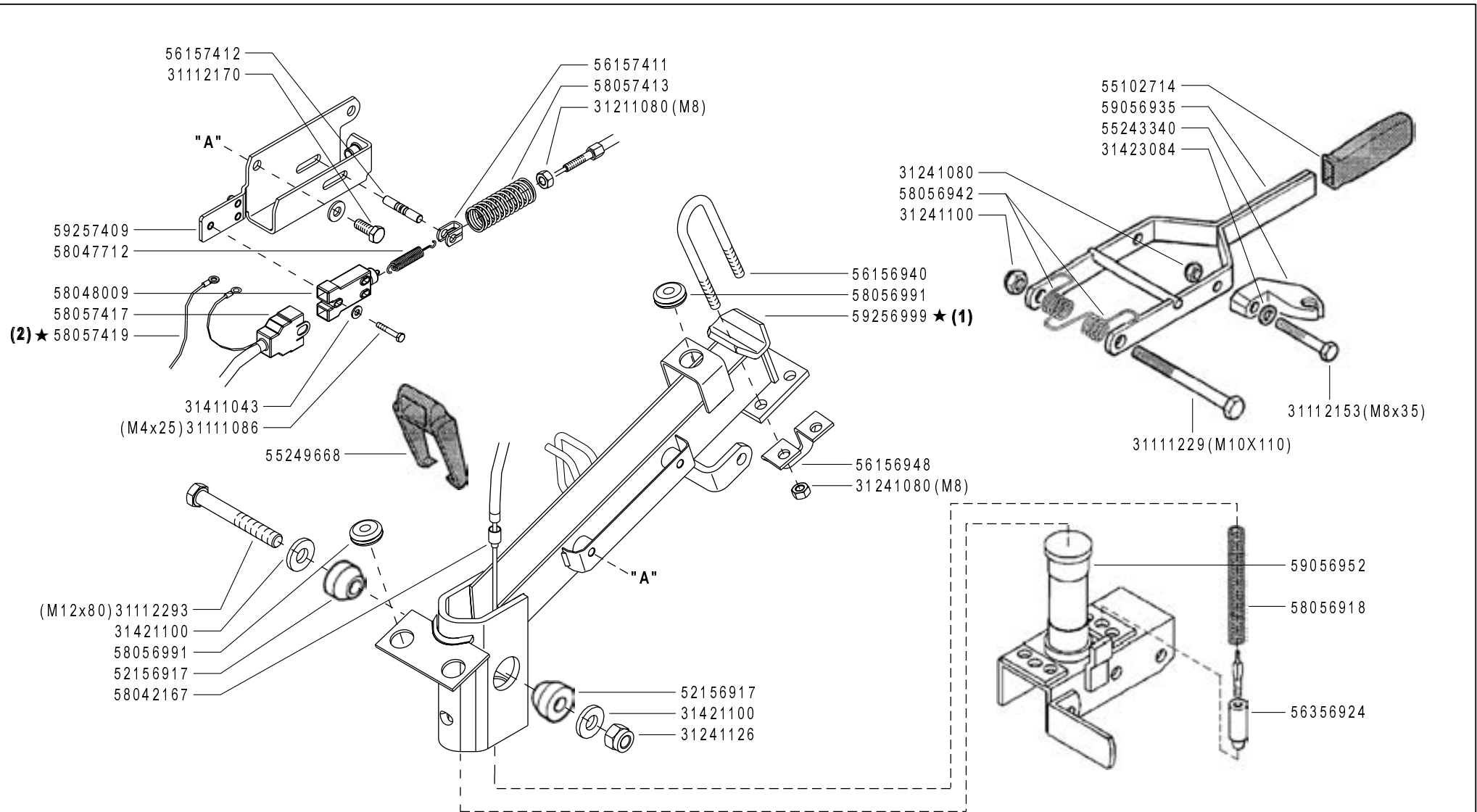

(1) sostituisce 59056995

 500 serie GRIFON	PIANTONE (515GR - 515L GR - 515S GR)		DALLA MACCHINA DE LA MAQUINA DE LA MACHINE FROM THE MACHINE AB DER MASCHINE ★ N.	Rev.	H01	1
	STEERING COLUMN COLUMNNA	PLANTON LENKSÄULE				
				(1) 822388	09/2008	
				(2) 794196		

Pos.	Code	Q.ty	Description	Notes
31111086	31111086	1	SCREW TE M4X25 UNI 5739 8G	
31111229	31111229	1	SCREW TE M10X110 UNI 5737 8G	
31112153	31112153	1	SCREW TE M8X35 UNI 5739 8G	
31112170	31112170	1	SCREW TE C/F M8X20 DIN 6921	
31112293	31112293	1	SCREW TE M12X80 UNI 5737	
31211080	31211080	1	NUT M8	
31241080	31241080	1	SELFLOCK NUT M8	
31241126	31241126	1	SELFLOCK NUT M12	
31411043	31411043	1	WASHER 4,3X9	
31421100	31421100	1	CUP SPRING	
31423084	31423084	1	SPRING WASHER 8,4	
52156917	52156917	1	WEDGE	
55102714	55102714	1	KNOB	
55243340	55243340	1	SUPPORT	
55249668	55249668	1	PASSING	
56156940	56156940	1	U BOLT	
56156948	56156948	1	STOP	
56157411	56157411	1	FORK	
56157412	56157412	1	PIN	
56356924	56356924	1	FERRULE	
58042167	58042167	1	SHEATH TERMINAL	
58047712	58047712	1	SPRING	
58048009	58048009	1	SWITCH	
58056918	58056918	1	SPRING	
58056942	58056942	1	SPRING	
58056991	58056991	1	CABLE GLAND	
58057413	58057413	1	RETAINING SPRING	
58057417	58057417	1	WIRING	
58057419	58057419	1	WIRING	
59056935	59056935	1	LEVER	
59056952	59056952	1	SUPPORT	
59256999	59256999	1	COLUMN	
59257409	59257409	1	SUPPORT	

SERIAL

STEERING COLUMN

CODE REV

H01_1_59887

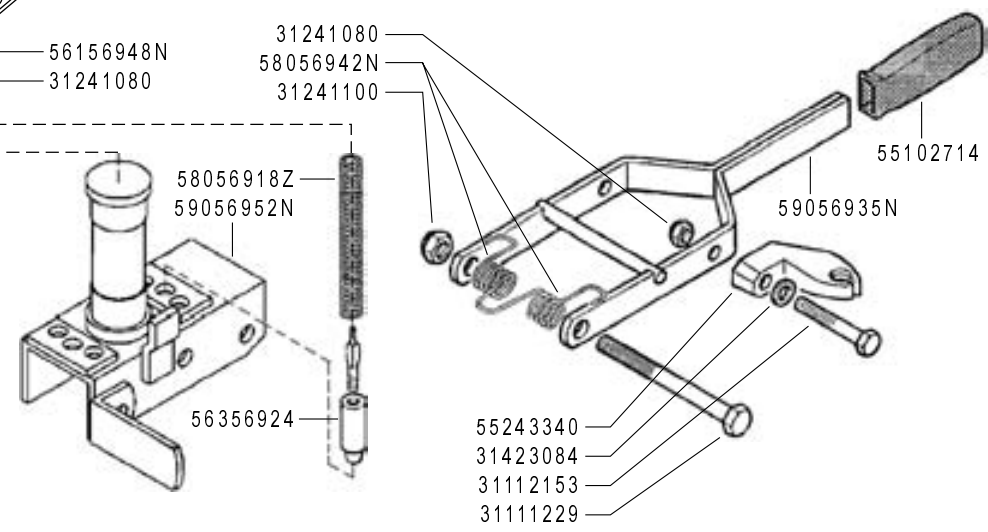
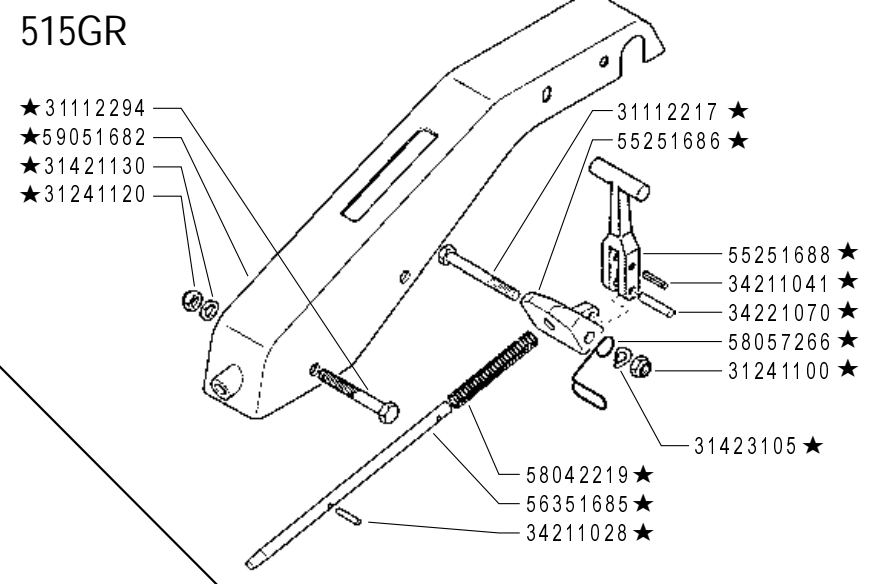
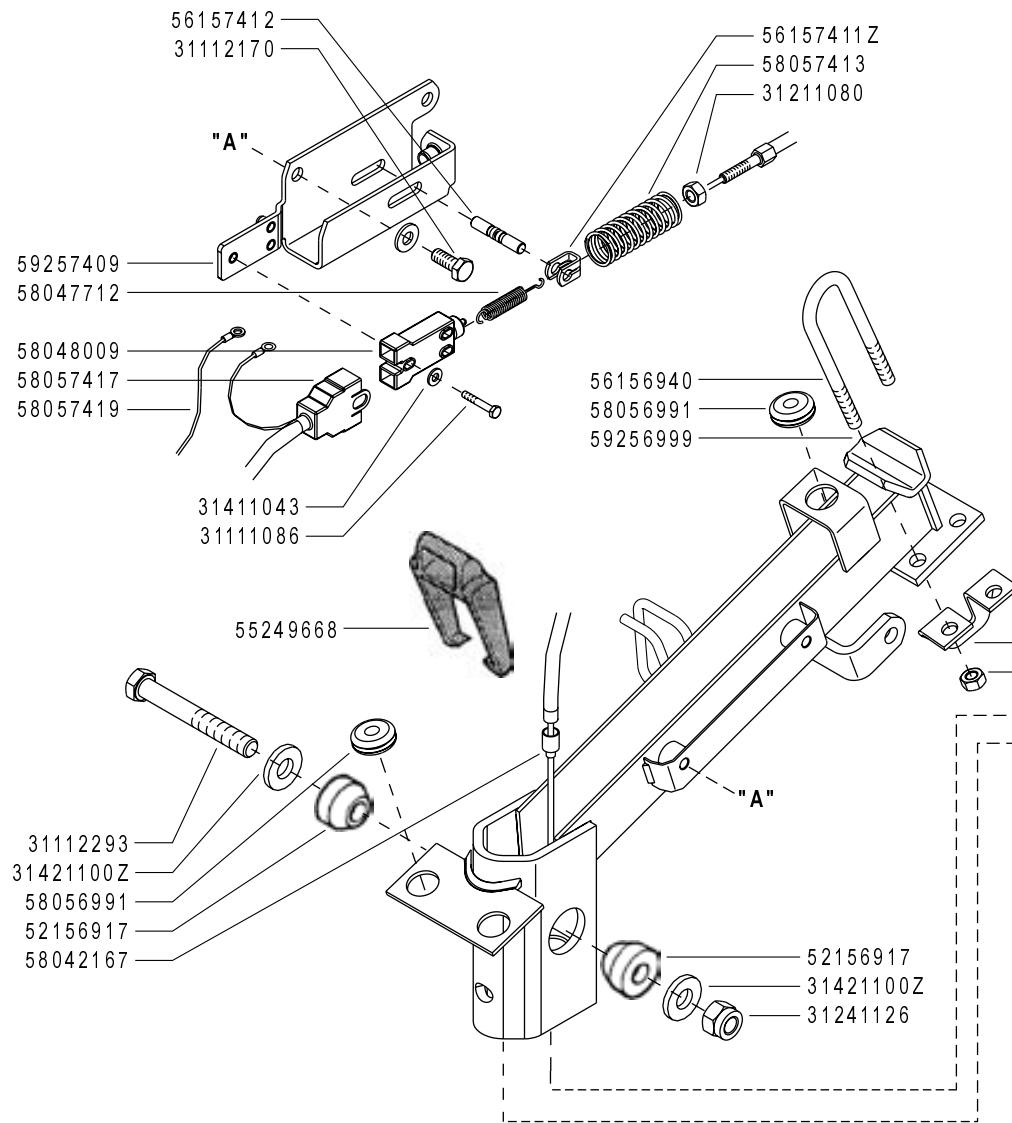

FERRARI 500 serie GRIFON

PIANTONE
(515GR - 515L GR - 515S GR - 515SL GR ★)
STEERING COLUMN
COLUMNNA

PLANTON
LENKSÄULE

DALLA MACCHINA
DE LA MAQUINA
DE LA MACHINE
FROM THE MACHINE
AB DER MASCHINE

★N.

ERRATA CORRIGE
825532 (515GR)

Rev. **H01** 2
02/2009

Pos.	Code	Q.ty	Description	Notes
31111086	31111086	1	SCREW TE M4X25 UNI 5739 8G	
31111229	31111229	1	SCREW TE M10X110 UNI 5737 8G	
31112153	31112153	1	SCREW TE M8X35 UNI 5739 8G	
31112170	31112170	1	SCREW TE C/F M8X20 DIN 6921	
31112217	31112217	1	SCREW TE M10X80 UNI 5737	
31112293	31112293	1	SCREW TE M12X80 UNI 5737	
31112294	31112294	1	SCREW TE M12X85 UNI 5737	
31211080	31211080	1	NUT M8	
31241080	31241080	1	SELFLOCK NUT M8	
31241100	31241100	1	SELFLOCK NUT M10 6S	
31241120	31241120	1	SELFLOCK NUT M12	
31241126	31241126	1	SELFLOCK NUT M12	
31411043	31411043	1	WASHER 4,3X9	
31421130	31421130	1	WASHER	
31423084	31423084	1	SPRING WASHER 8,4	
31423105	31423105	1	SPRING WASHER 10,5	
34211028	34211028	1	ROLL PIN	
34211041	34211041	1	ROLL PIN	
34221070	34221070	1	CYLINDRICAL PLUG 8X50 UNI 1707	
52156917	52156917	1	WEDGE	
55102714	55102714	1	KNOB	
55243340	55243340	1	SUPPORT	
55249668	55249668	1	PASSING	
55251686	55251686	1	LEVER BEARING	
55251688	55251688	1	LEVER	
56156940	56156940	1	U BOLT	
56157412	56157412	1	PIN	
56351685	56351685	1	ROD	
56356924	56356924	1	FERRULE	
58042167	58042167	1	SHEATH TERMINAL	
58042219	58042219	1	SPRING	
58047712	58047712	1	SPRING	
58048009	58048009	1	SWITCH	
58056991	58056991	1	CABLE GLAND	

SERIAL
START
825532

STEERING COLUMN

Version: 515GR, 515L GR, 515S GR, 515SL GR

CODE REV

H01_2_67804

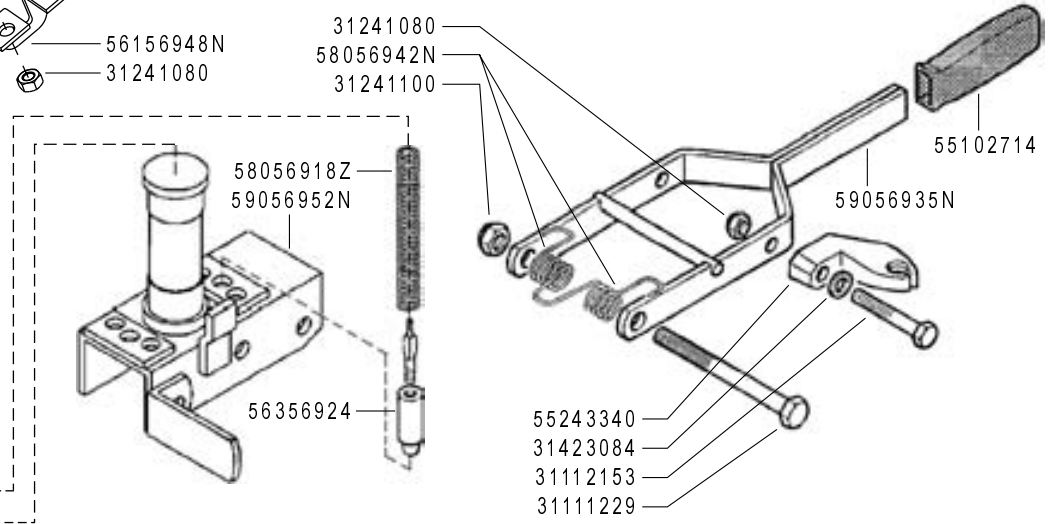
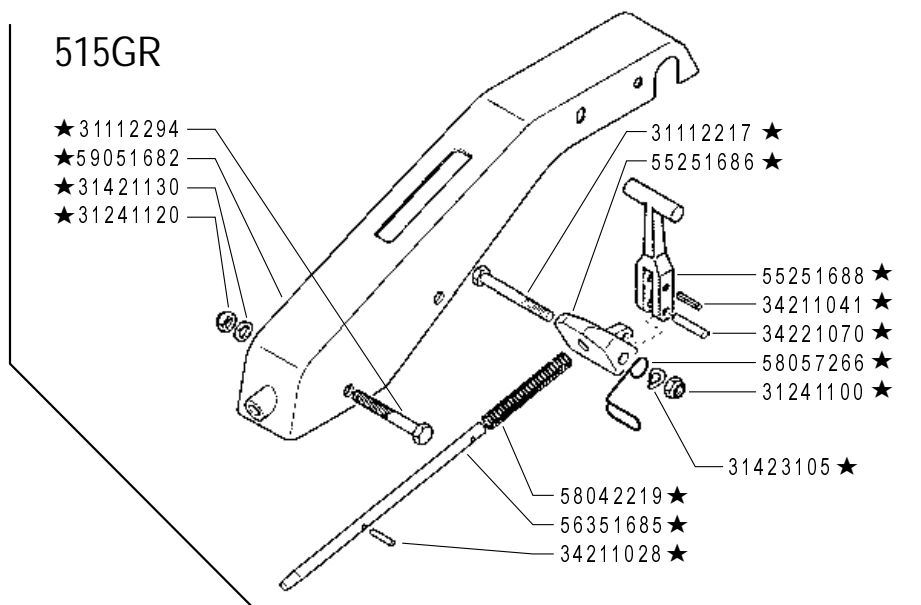
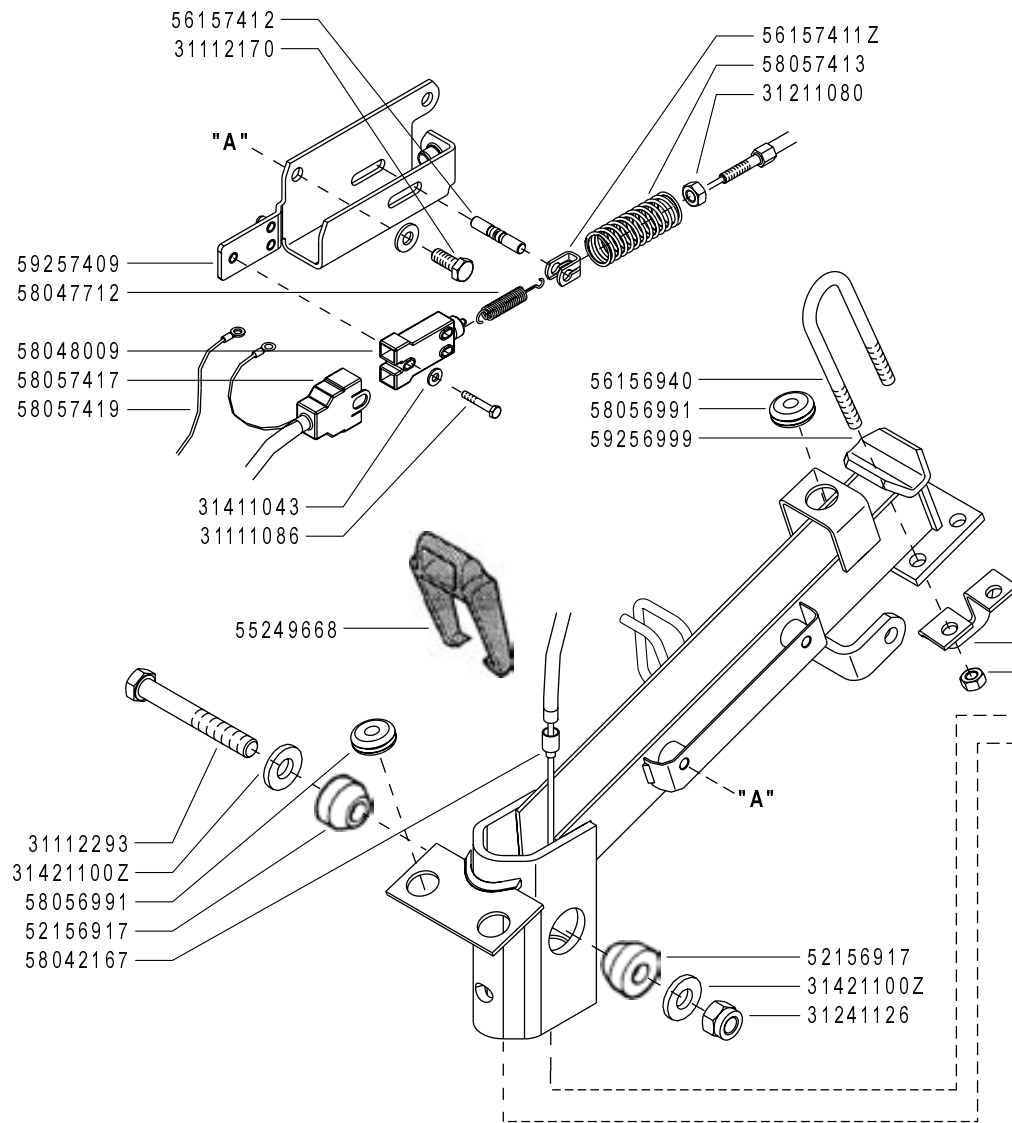

	500 serie GRIFON	PIANTONE (515GR - 515L GR - 515S GR - 515SL GR ★)		DALLA MACCHINA DE LA MAQUINA FROM THE MACHINE AB DER MASCHINE	ERRATA CORRIGE	Rev. H01 2
		STEERING COLUMN COLUMNNA	PLANTON LENKSÄULE		★ N.	

Pos.	Code	Q.ty	Description	Notes
58057266	58057266	1	HOLDER	
58057413	58057413	1	RETAINING SPRING	
58057417	58057417	1	WIRING	
58057419	58057419	1	WIRING	
59051682	59051682	1	HANDLE BAR COLUMN	
59256999	59256999	1	COLUMN	
59257409	59257409	1	SUPPORT	
31421100	31421100Z	1	CUP SPRING	
56156948	56156948N	1	STOP	
56157411	56157411Z	1	FORK	
58056918	58056918Z	1	SPRING	
58056942	58056942N	1	SPRING	
59056935	59056935N	1	LEVER	
59056952	59056952N	1	SUPPORT	

SERIAL
START
825532

STEERING COLUMN

Version: 515GR, 515L GR, 515S GR, 515SL GR

CODE REV

H01_2_67804

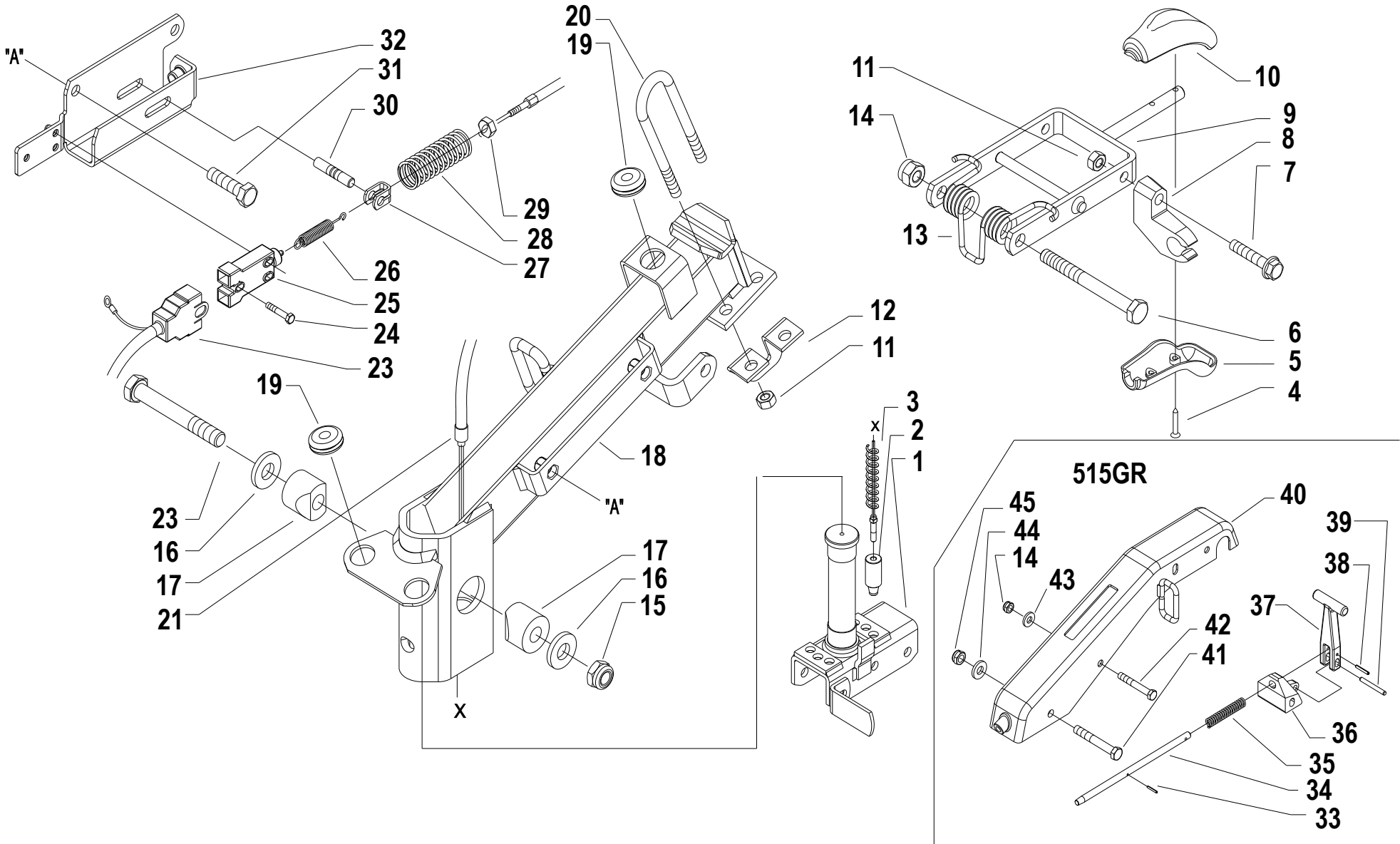

Pos.	Code	Q.ty	Description	Notes
1	59056952N	1	SUPPORT	
2	56356924	1	FERRULE	
3	58056918Z	1	SPRING	
4	31100451	1	SCREW 3,5X25	
5	55157213	1	GRIP	
6	31111229	1	SCREW TE M10X110 UNI 5737 8G	
7	31112165	1	SCREW TE C/F M8X35 DIN 6921 8G	
8	55243340	1	SUPPORT	
9	59057010N	1	LEVER	
10	55157212	1	GRIP	
11	31241080	1	SELFLOCK NUT M8	
12	56156948N	1	STOP	
13	58056942N	1	SPRING	
14	31241100	1	SELFLOCK NUT M10 6S	
15	31241126	1	SELFLOCK NUT M12	
16	31421100Z	1	CUP SPRING	
17	52156917	1	WEDGE	
18	59256999	1	COLUMN	
19	58056991	1	CABLE GLAND	
20	56156940	1	U BOLT	
21	58042167	1	SHEATH TERMINAL	
22	31112293	1	SCREW TE M12X80 UNI 5737	
23	58057417	1	WIRING	
24	31121024	1	SCREW TBCEI FL.M4X25	
25	58048009	1	SWITCH	
26	58047712	1	SPRING	
27	56157411Z	1	FORK	
28	58057413	1	RETAINING SPRING	
29	31211080	1	NUT M8	
30	56157412	1	PIN	
31	31112170	1	SCREW TE C/F M8X20 DIN 6921	
32	59257409	1	SUPPORT	
33	34211028	1	ROLL PIN	
34	56351685Z	1	ROD	

SERIAL

STEERING COLUMN

CODE REV

H.01.02.A0011_03

Pos.	Code	Q.ty	Description	Notes
35	58042219	1	SPRING	
36	55251686	1	LEVER BEARING	
37	55251688	1	LEVER	
38	34211041	1	ROLL PIN	
39	34221070	1	CYLINDRICAL PLUG 8X50 UNI 1707	
40	59056817V	1	COLUMN	
41	31112294	1	SCREW TE M12X85 UNI 5737	
42	31112217	1	SCREW TE M10X80 UNI 5737	
43	31423105	1	SPRING WASHER 10,5	
44	31421130	1	WASHER	
45	31241120	1	SELFLOCK NUT M12	

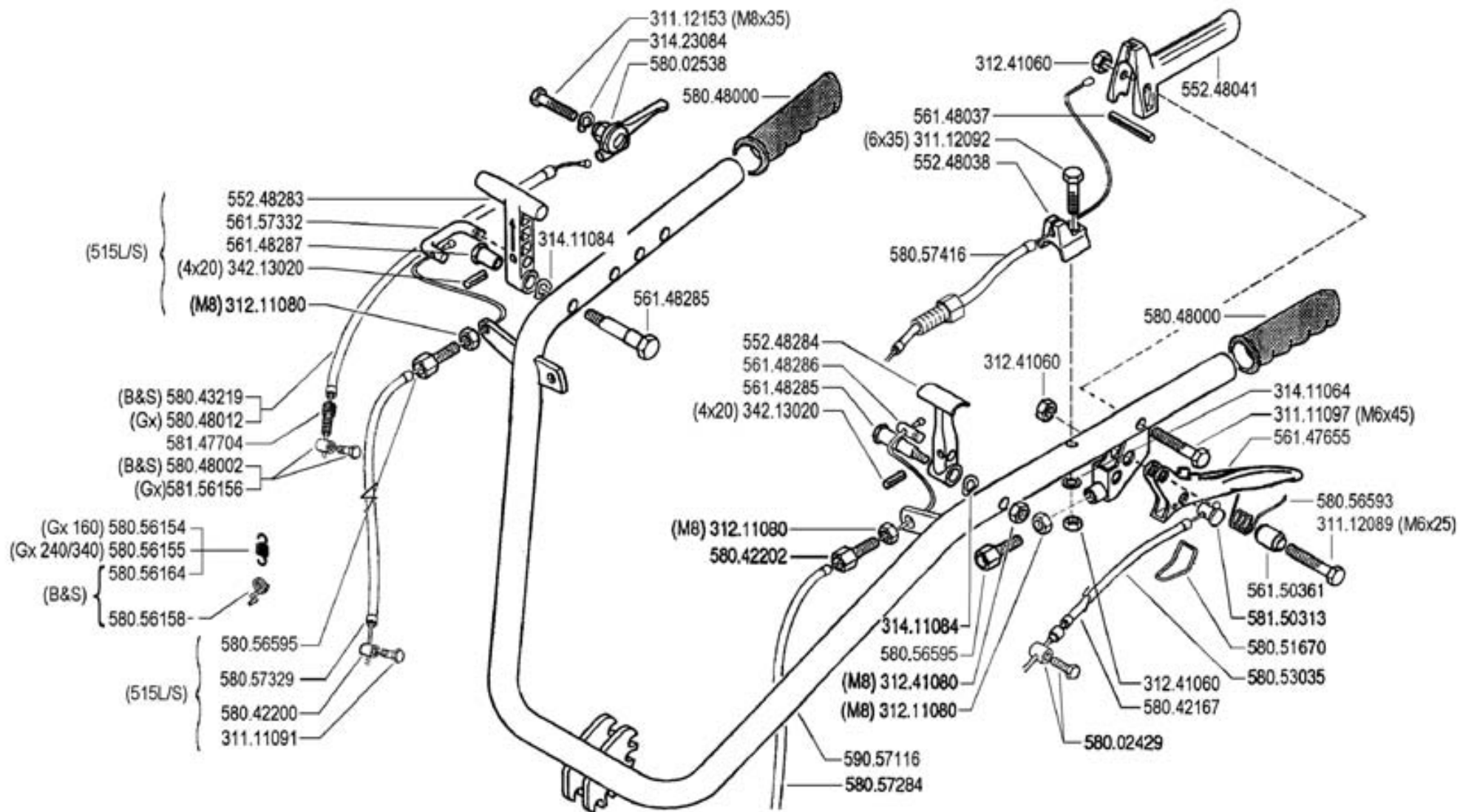

FERRARI

500 serie GRIFON

MANUBRIO (515 GR - 515L GR - 515S GR)

HANDLEBAR
 MANILLAR

MANCHERON
 LENKER

DALLA MACCHINA
 DE LA MAQUINA
 DE LA MACHINE
 FROM THE MACHINE
 AB DER MASCHINE

N.

I01

Rev.
0

09/2004

ZITNE

Pos.	Code	Q.ty	Description	Notes
31111091	31111091	1	SCREW E M6X14 UNI 5739 8G	
31111097	31111097	1	SCREW TE M6X45 UNI 5737 8G	
31112089	31112089	1	SCREW TE M6X25 UNI 5739 8G	
31112092	31112092	1	SCREW TE M6X35 UNI 5739 8G	
31112153	31112153	1	SCREW TE M8X35 UNI 5739 8G	
31211080	31211080	1	NUT M8	
31241060	31241060	1	SELFLOCK NUT M6	
31241080	31241080	1	SELFLOCK NUT M8	
31411064	31411064	1	WASHER 6,4x12,5	
31411084	31411084	1	WASHER 8,4x17	
31423084	31423084	1	SPRING WASHER 8,4	
34213020	34213020	1	ROLL PIN	
55248038	55248038	1	STOP	
55248041	55248041	1	LEVER	
55248283	55248283	1	COMMAND LEVER	
55248284	55248284	1	LEVER	
56147655	56147655	1	CLUTCH LEVER	
56148037	56148037	1	LEVER STOP	
56148285	56148285	1	PIN	
56148286	56148286	1	PIN	
56148287	56148287	1	STUD BOLT	
56150361	56150361	1	SPACER	
56157332	56157332	1	U BOLT	
58002429	58002429	1	CLAMPING SCREW	
58002538	58002538	1	COMMAND LEVER	
58042167	58042167	1	SHEATH TERMINAL	
58042200	58042200	1	CLAMPING SCREW	
58042202	58042202	1	ADJUSTING SCREW	
58043219	58043219	1	LINE AND SHEATH	
58048000	58048000	1	KNOB	
58048002	58048002	1	CLAMPING SCREW	
58048012	58048012	1	LINE AND SHEATH	
58051670	58051670	1	CLEVIS	
58053035	58053035	1	LINE AND SHEATH	

SERIAL

HANDLEBAR

CODE REV

I01_0_22914

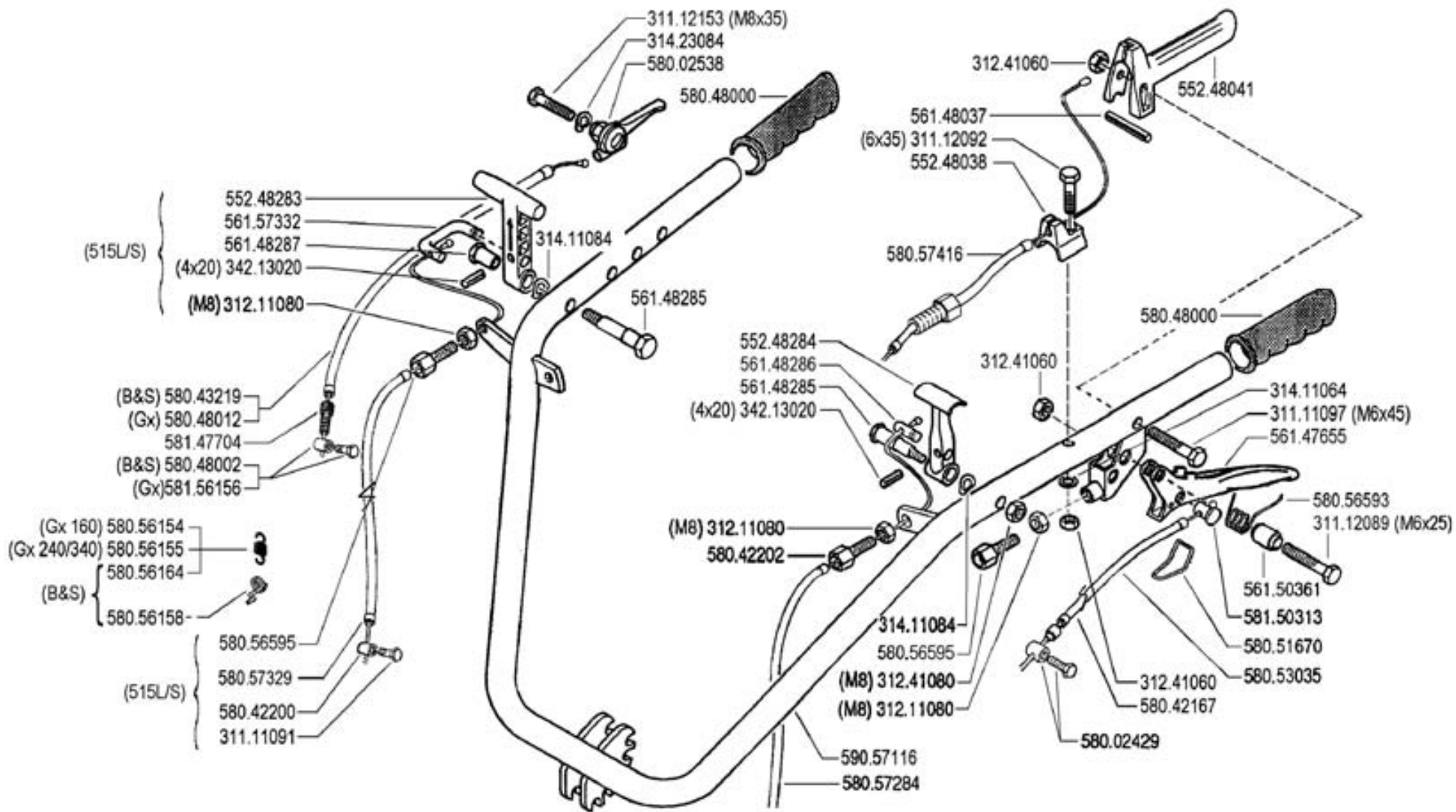

FERRARI

500 serie GRIFON

MANUBRIO (515 GR - 515L GR - 515S GR)

HANDLEBAR
MANILLAR

MANCHERON
LENKER

DALLA MACCHINA
DE LA MAQUINA
DE LA MACHINE
FROM THE MACHINE
AB DER MASCHINE

N.

I01

Rev. 0

09/2004

27/04

Pos.	Code	Q.ty	Description	Notes
58056154	58056154	1	RESTORING SPRING	Utilizzato con motore GX200
58056155	58056155	1	RESTORING SPRING	Utilizzato con motore GX270
58056158	58056158	1	COUPLING	
58056164	58056164	1	RESTORING SPRING	
58056593	58056593	1	SPRING	
58056595	58056595	1	ADJUSTING SCREW	
58057284	58057284	1	LINE AND SHEATH	
58057329	58057329	1	LINE AND SHEATH	
58057416	58057416	1	LINE AND SHEATH	
58147704	58147704	1	ADJUSTING SCREW	
58150313	58150313	1	CABLE CLAMP	
58156156	58156156	1	TERMINAL	
59057116	59057116	1	COMPLETE HANDLE BAR	

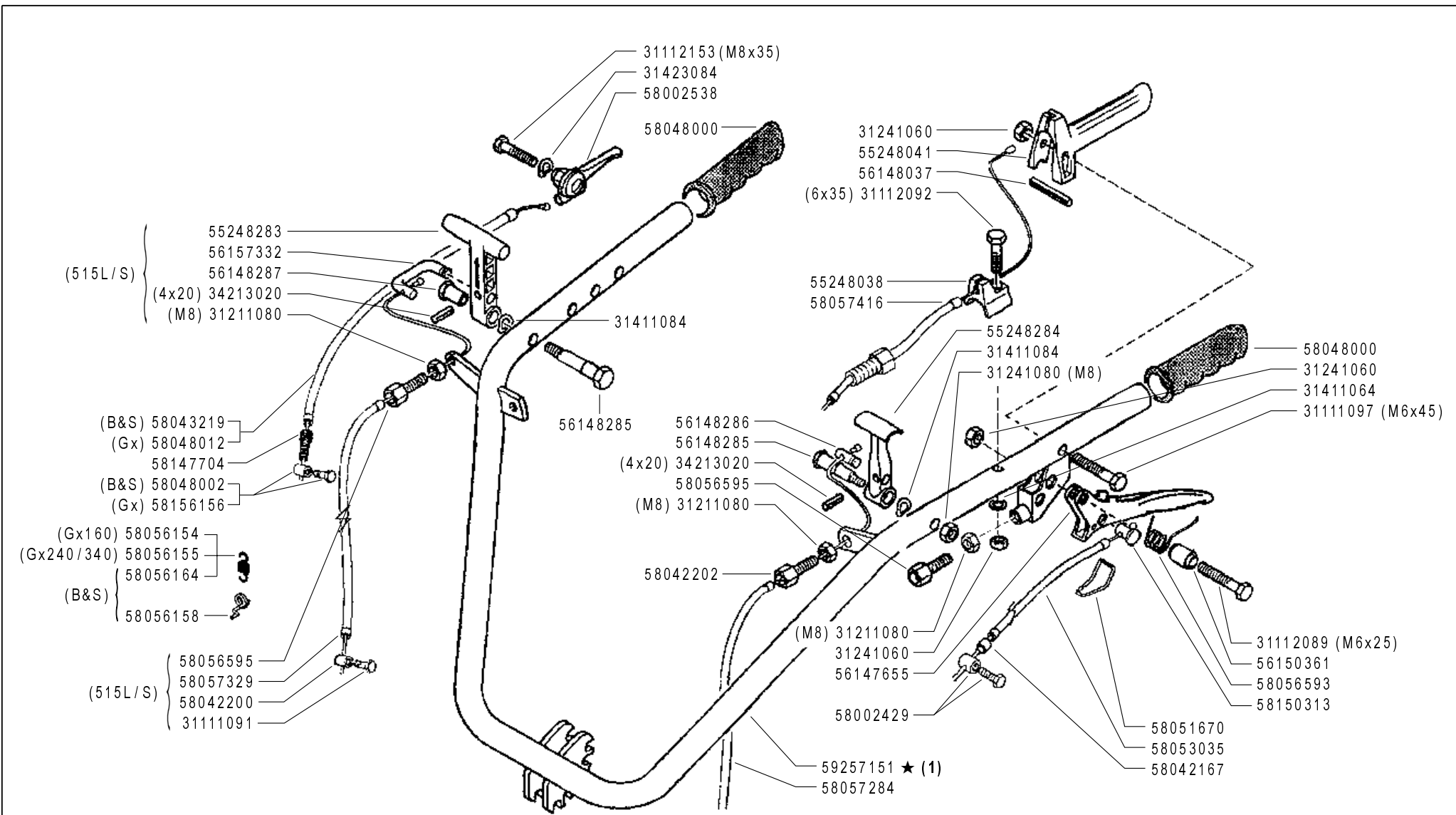

(1) sostituisce 59057116

 500 serie GRIFON	MANUBRIO (515 GR - 515L GR - 515S GR)		DALLA MACCHINA DE LA MAQUINA FROM THE MACHINE AB DER MASCHINE ★ N.	AGGIORNAMENTO	I01 07/2006	Rev.
	HANDLEBAR	MANCHERON		REVISION		1
	MANILLAR	LENKER		MISE A JOUR		
				APLAZAMIENTO		
				ANPASSUNG		

Pos.	Code	Q.ty	Description	Notes
31111091	31111091	1	SCREW E M6X14 UNI 5739 8G	
31111097	31111097	1	SCREW TE M6X45 UNI 5737 8G	
31112089	31112089	1	SCREW TE M6X25 UNI 5739 8G	
31112092	31112092	1	SCREW TE M6X35 UNI 5739 8G	
31112153	31112153	1	SCREW TE M8X35 UNI 5739 8G	
31211080	31211080	1	NUT M8	
31241060	31241060	1	SELFLOCK NUT M6	
31241080	31241080	1	SELFLOCK NUT M8	
31411064	31411064	1	WASHER 6,4x12,5	
31411084	31411084	1	WASHER 8,4x17	
31423084	31423084	1	SPRING WASHER 8,4	
34213020	34213020	1	ROLL PIN	
55248038	55248038	1	STOP	
55248041	55248041	1	LEVER	
55248283	55248283	1	COMMAND LEVER	
55248284	55248284	1	LEVER	
56147655	56147655	1	CLUTCH LEVER	
56148037	56148037	1	LEVER STOP	
56148285	56148285	1	PIN	
56148286	56148286	1	PIN	
56148287	56148287	1	STUD BOLT	
56150361	56150361	1	SPACER	
56157332	56157332	1	U BOLT	
58002429	58002429	1	CLAMPING SCREW	
58002538	58002538	1	COMMAND LEVER	
58042167	58042167	1	SHEATH TERMINAL	
58042200	58042200	1	CLAMPING SCREW	
58042202	58042202	1	ADJUSTING SCREW	
58043219	58043219	1	LINE AND SHEATH	
58048000	58048000	1	KNOB	
58048002	58048002	1	CLAMPING SCREW	
58048012	58048012	1	LINE AND SHEATH	
58051670	58051670	1	CLEVIS	
58053035	58053035	1	LINE AND SHEATH	

SERIAL

HANDLEBAR

CODE REV

I01_1_32971

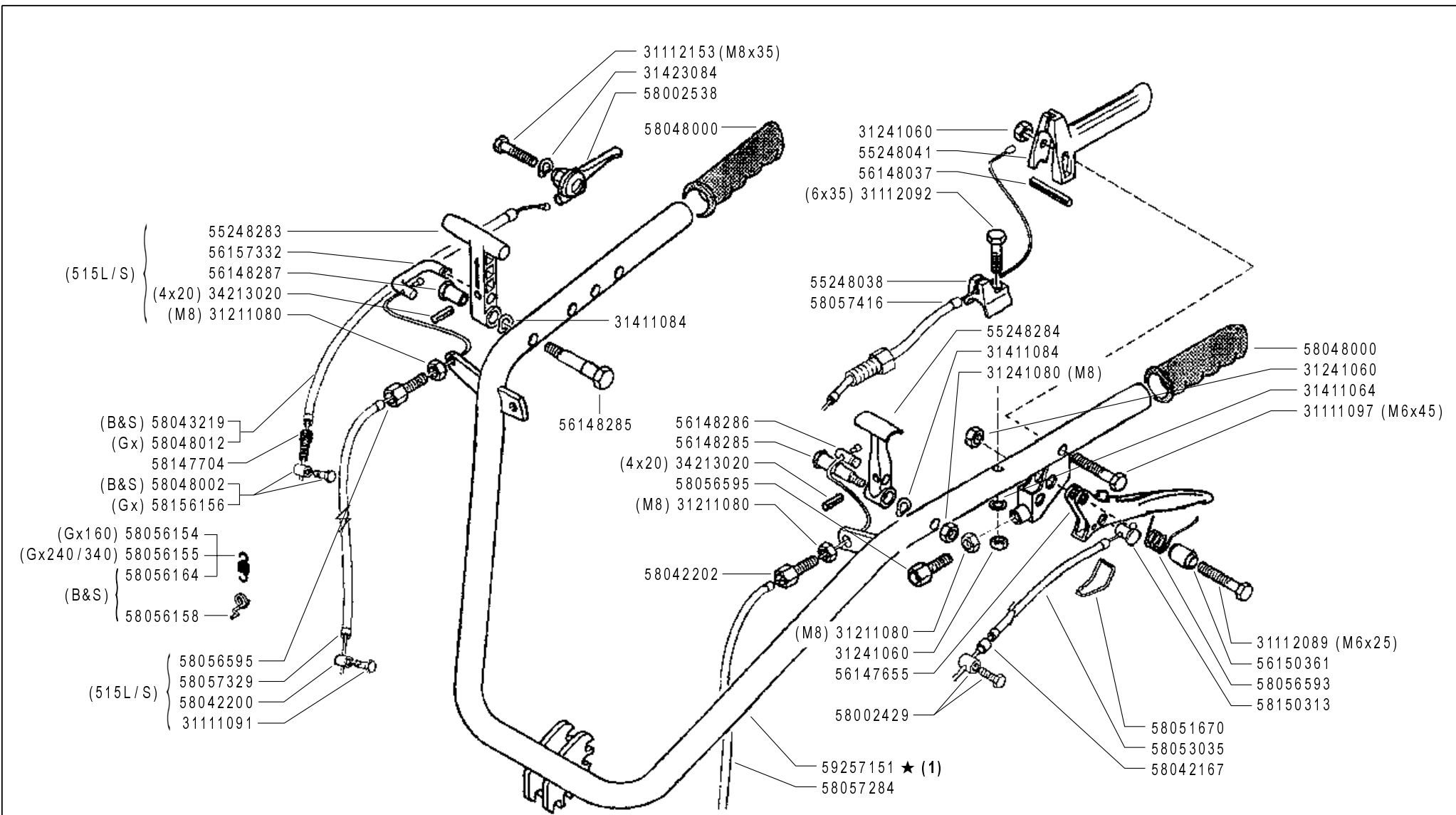

(1) sostituisce 59057116

 500 serie GRIFON	MANUBRIO (515 GR - 515L GR - 515S GR)		DALLA MACCHINA DE LA MAQUINA FROM THE MACHINE AB DER MASCHINE ★ N.	AGGIORNAMENTO	I01 07/2006	Rev.
	HANDLEBAR MANILLAR	MANCHERON LENKER		REVISION		1
				MISE A JOUR		
				APLAZAMIENTO		
				ANPASSUNG		

Pos.	Code	Q.ty	Description	Notes
58056154	58056154	1	RESTORING SPRING	Utilizzato con motore GX200
58056155	58056155	1	RESTORING SPRING	Utilizzato con motore GX270
58056158	58056158	1	COUPLING	
58056164	58056164	1	RESTORING SPRING	
58056593	58056593	1	SPRING	
58056595	58056595	1	ADJUSTING SCREW	
58057284	58057284	1	LINE AND SHEATH	
58057329	58057329	1	LINE AND SHEATH	
58057416	58057416	1	LINE AND SHEATH	
58147704	58147704	1	ADJUSTING SCREW	
58150313	58150313	1	CABLE CLAMP	
58156156	58156156	1	TERMINAL	
59257151	59257151	1	COMPLETE HANDLE BAR	

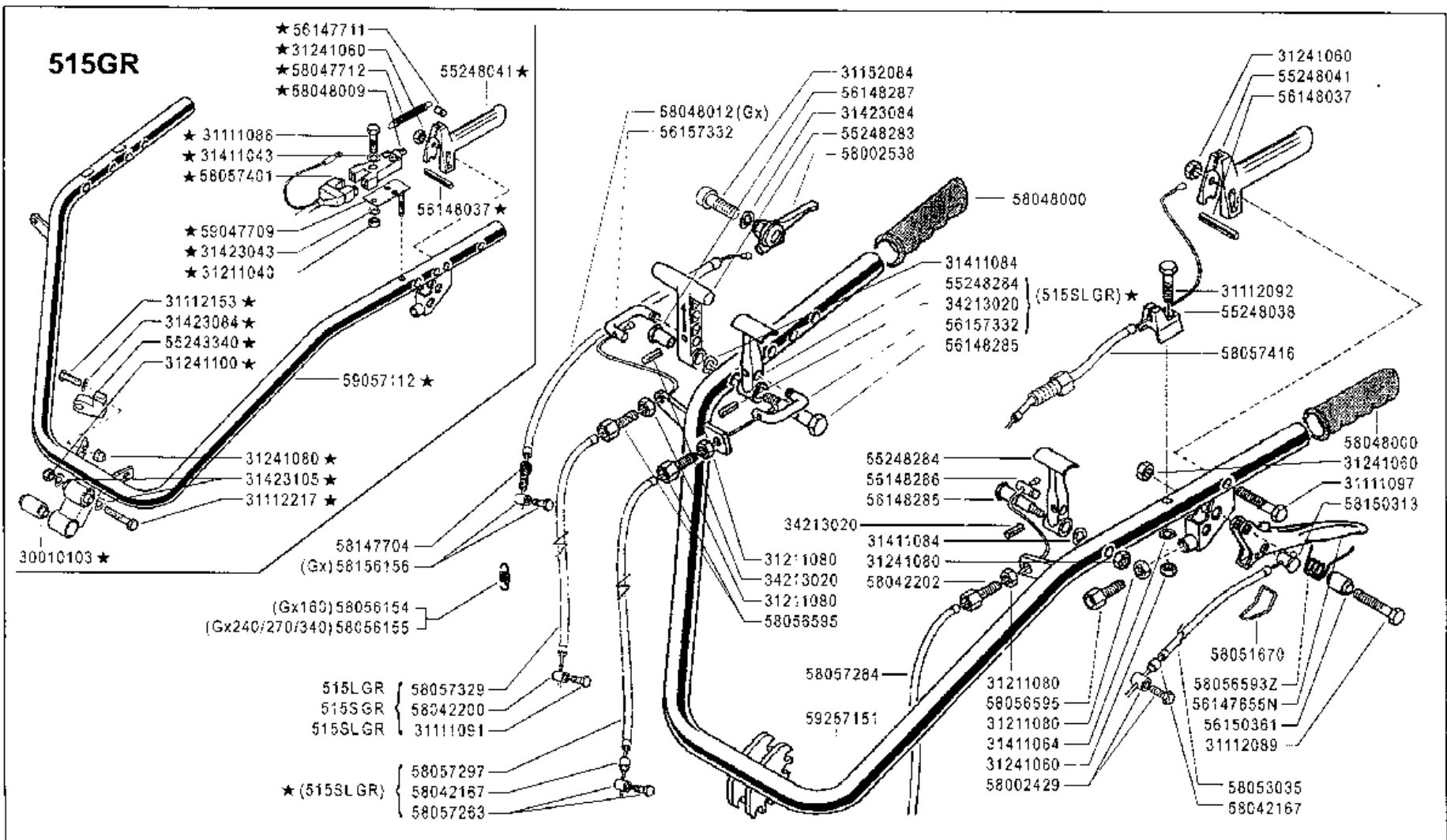

FERRARI

500 serie GRIFON

MANUBRIG
(515GR - 515LGR - 515SGR - 515SLGR ★)

ENGINE GUARDS
PROTECCIONES MOTOR

PROTECTIONS MOTEUR
MOTOR SCHUTZ

DALLA MACCHINA
DE LA MAQUINA
DE LA MACHINE
FROM THE MACHINE
AB DER MASCHINE

ERRATA CORRIGE

★ N.

825532 (515GR)

I01
2

02/2009

ZINNE

Pos.	Code	Q.ty	Description	Notes
30010103	30010103	1	SILENT-BLOCK 10,2X30X45X60,5	
31111086	31111086	1	SCREW TE M4X25 UNI 5739 8G	
31111091	31111091	1	SCREW E M6X14 UNI 5739 8G	
31111097	31111097	1	SCREW TE M6X45 UNI 5737 8G	
31112089	31112089	1	SCREW TE M6X25 UNI 5739 8G	
31112092	31112092	1	SCREW TE M6X35 UNI 5739 8G	
31112153	31112153	1	SCREW TE M8X35 UNI 5739 8G	
31112217	31112217	1	SCREW TE M10X80 UNI 5737	
31152084	31152084	1	SCREW TCEI M8X35 UNI 5931	
31211040	31211040	1	NUT M4	
31211080	31211080	1	NUT M8	
31241060	31241060	1	SELFLOCK NUT M6	
31241080	31241080	1	SELFLOCK NUT M8	
31241100	31241100	1	SELFLOCK NUT M10 6S	
31411043	31411043	1	WASHER 4,3X9	
31411064	31411064	1	WASHER 6,4x12,5	
31411084	31411084	1	WASHER 8,4x17	
31423043	31423043	1	SPRING WASHER 4,3	
31423084	31423084	1	SPRING WASHER 8,4	
31423105	31423105	1	SPRING WASHER 10,5	
34213020	34213020	1	ROLL PIN	
55243340	55243340	1	SUPPORT	
55248038	55248038	1	STOP	
55248041	55248041	1	LEVER	
55248283	55248283	1	COMMAND LEVER	
55248284	55248284	1	LEVER	
56147711	56147711	1	PIN	
56148037	56148037	1	LEVER STOP	
56148285	56148285	1	PIN	
56148286	56148286	1	PIN	
56150361	56150361	1	SPACER	
56157332	56157332	1	U BOLT	
58002429	58002429	1	CLAMPING SCREW	
58042167	58042167	1	SHEATH TERMINAL	

SERIAL
START
825532

HANDLEBAR

Version: 515GR, 515L GR, 515S GR, 515SL GR

CODE REV

I01_2_67839

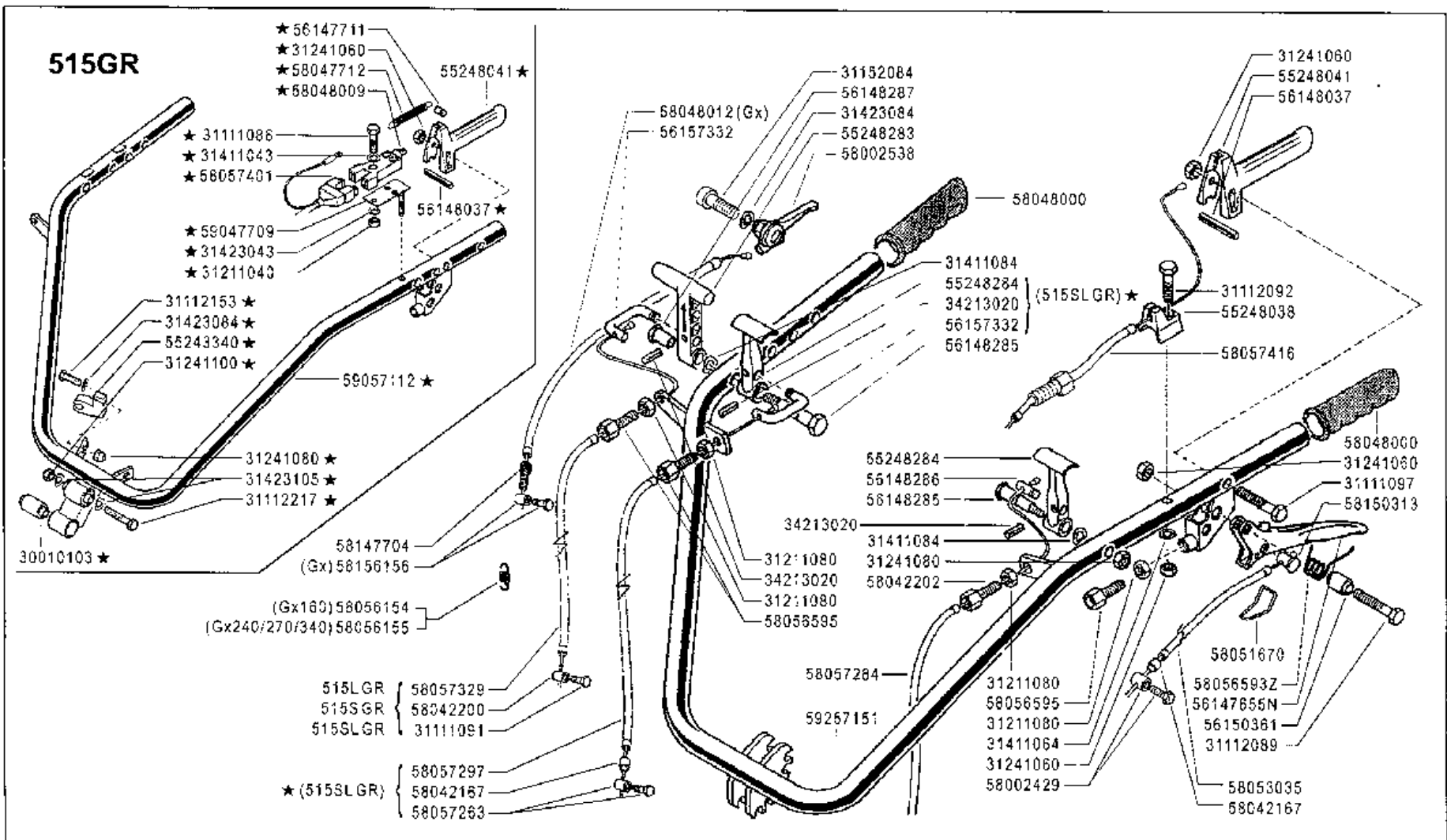

FERRARI

500 serie GRIFON

MANUBRIG
(515GR - 515LGR - 515SGR - 515SLGR ★)

ENGINE GUARDS
PROTECCIONES MOTOR

PROTECTIONS MOTEUR
MOTOR SCHUTZ

DALLA MACCHINA
DE LA MAQUINA
DE LA MACHINE
FROM THE MACHINE
AB DER MASCHINE

ERRATA CORRIGE

★ N.

825532 (515GR)

I01

Rev. **2**

02/2009

ZINNE

Pos.	Code	Q.ty	Description	Notes
58042200	58042200	1	CLAMPING SCREW	
58042202	58042202	1	ADJUSTING SCREW	
58047712	58047712	1	SPRING	
58048000	58048000	1	KNOB	
58048009	58048009	1	SWITCH	
58048012	58048012	1	LINE AND SHEATH	
58051670	58051670	1	CLEVIS	
58053035	58053035	1	LINE AND SHEATH	
58056154	58056154	1	RESTORING SPRING	Utilizzato con motore GX200
58056155	58056155	1	RESTORING SPRING	Utilizzato con motore GX270
58056158	58056158	1	COUPLING	
58056164	58056164	1	RESTORING SPRING	
58056595	58056595	1	ADJUSTING SCREW	
58057263	58057263	1	CLAMPING SCREW	
58057284	58057284	1	LINE AND SHEATH	
58057297	58057297	1	LINE AND SHEATH	
58057329	58057329	1	LINE AND SHEATH	
58057401	58057401	1	WIRING	
58057416	58057416	1	LINE AND SHEATH	
58147704	58147704	1	ADJUSTING SCREW	
58150313	58150313	1	CABLE CLAMP	
58156156	58156156	1	TERMINAL	
59047709	59047709	1	SWITCH SUPPORT	
59057112	59057112	1	COMPLETE HANDLE BAR	
59257151	59257151	1	COMPLETE HANDLE BAR	
56147655	56147655N	1	CLUTCH LEVER	
58056593	58056593Z	1	SPRING	

SERIAL
START
825532

HANDLEBAR

Version: 515GR, 515L GR, 515S GR, 515SL GR

CODE REV

I01_2_67839

HANDLEBAR

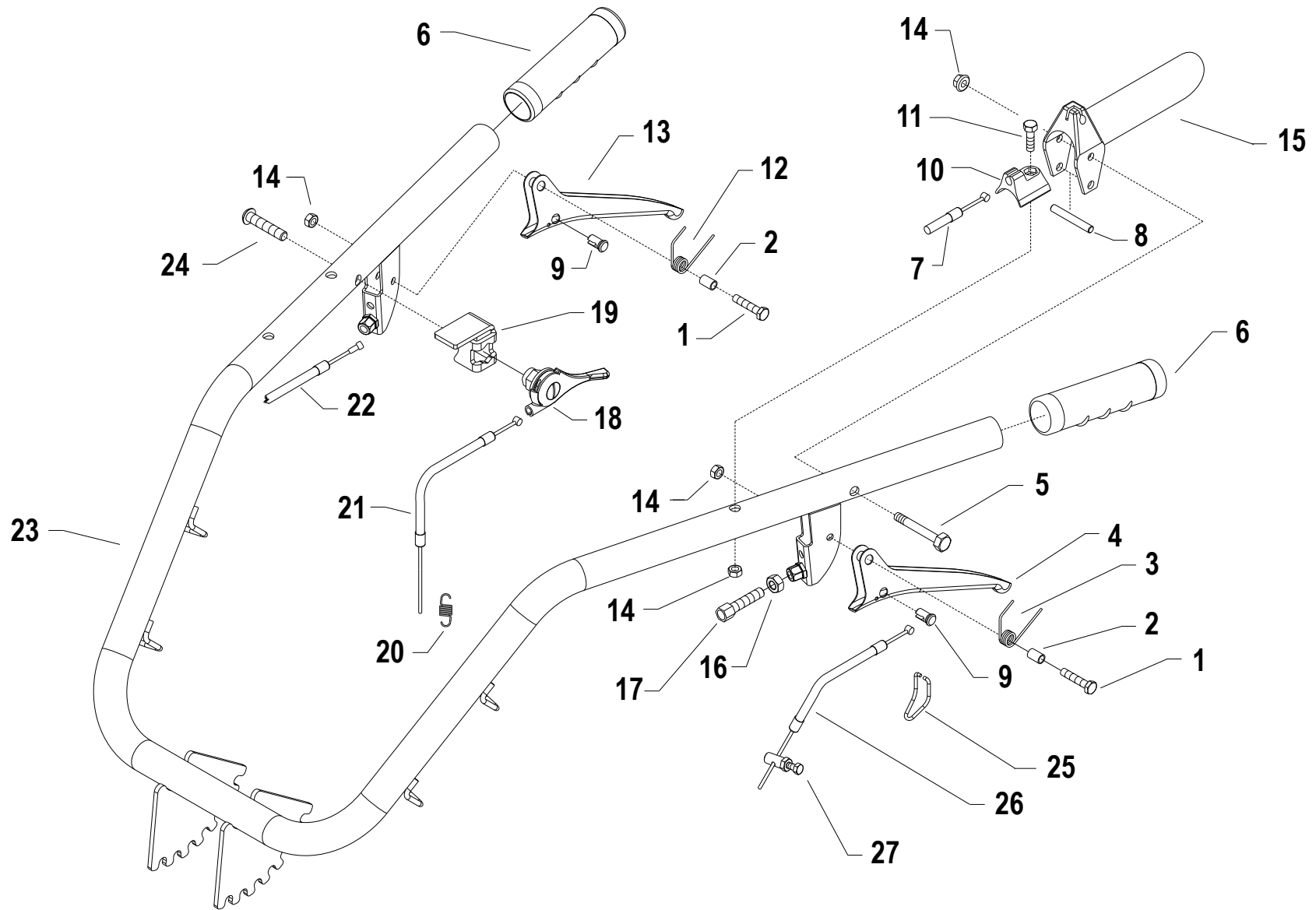

Pos.	Code	Q.ty	Description	Notes
1	31112089	1	SCREW TE M6X25 UNI 5739 8G	
2	56156603Z	1	SPACER	
3	58050345	1	SPRING	
4	56147655N	1	CLUTCH LEVER	
5	31111097	1	SCREW TE M6X45 UNI 5737 8G	
6	58048000	1	KNOB	
7	58048355	1	LINE AND SHEATH	For diesel engines
7	58057418	1	LINE AND SHEATH	
8	56148037	1	LEVER STOP	
9	58150313	1	CABLE CLAMP	
10	55248038	1	STOP	
11	31112092	1	SCREW TE M6X35 UNI 5739 8G	
12	58056593	1	SPRING	
13	56148470N	1	LEVER	
14	31241060	1	SELFLOCK NUT M6	
15	55248041	1	LEVER	
16	31211080	1	NUT M8	
17	58056595	1	ADJUSTING SCREW	
18	58002538	1	COMMAND LEVER	
19	56156874N	1	PANEL	
20	58056154	1	RESTORING SPRING	Utilizzato con motore GX200 - For motors GX200
20	58056155	1	RESTORING SPRING	Utilizzato con motore GX270 - For the engine GX270
21	58056815	1	LINE AND SHEATH	For motors GX200/GX270
22	58056193	1	COLUMN TRANSMISSION	
23	59257162	1	MANUBRIO MC USA C/CORTO C/P.I.	
24	31121020	1	SCREW TBCEI M8X40 ISO7380 10K Z	

Pos.	Code	Q.ty	Description	Notes
30010142	30010142	1	SILENT-BLOCK 10,2X30X45X49	
31111216	31111216	1	SCREW TE M10X70 UNI 5739 8G	
31112152	31112152	1	SCREW TE M8X30 UNI 5739 8G	
31241080	31241080	1	SELFLOCK NUT M8	
31241085	31241085	1	SELFLOCK NUT M8 6S	
31241100	31241100	1	SELFLOCK NUT M10 6S	
31312082	31312082	1	STUD BOLT M8X38X14X20	
31411104	31411104	1	WASHER 10,5x18	
31414130	31414130	1	WASHER 13	
31421083	31421083	1	WASHER	
31423084	31423084	1	SPRING WASHER 8,4	
34110028	34110028	1	SPLIT PIN	
34213020	34213020	1	ROLL PIN	
34213024	34213024	1	ROLL PIN	
34213061	34213061	1	ROLL PIN	
37911532	37911532	1	BALL 15/32	
38111191	38111191	1	O-RING 115 (11,91X2,62)	
38211400	38211400	1	OIL SEAL 14X22X4	
52357250	52357250	1	PIN	
55142076	55142076	1	KNOB	
55242528	55242528	1	JOINT	
55248379	55248379	1	JOINT	
55257313	55257313	1	ROLLER	
55257321	55257321	1	STOP	
56157257	56157257	1	SPACER	
56157271	56157271	1	COMMAND LEVER	
56157274	56157274	1	SQUARE	
56157283	56157283	1	GEARSHIFT ROD	
56157312	56157312	1	ROD	
56157324	56157324	1	PTO LEVER	
56157349	56157349	1	SELECTOR	
56157356	56157356	1	GEAR SELECTOR	
58043176	58043176	1	SPRING	
58057232	58057232	1	SPRING	

SERIAL

CONTROLS

CODE REV

J01_0_23105

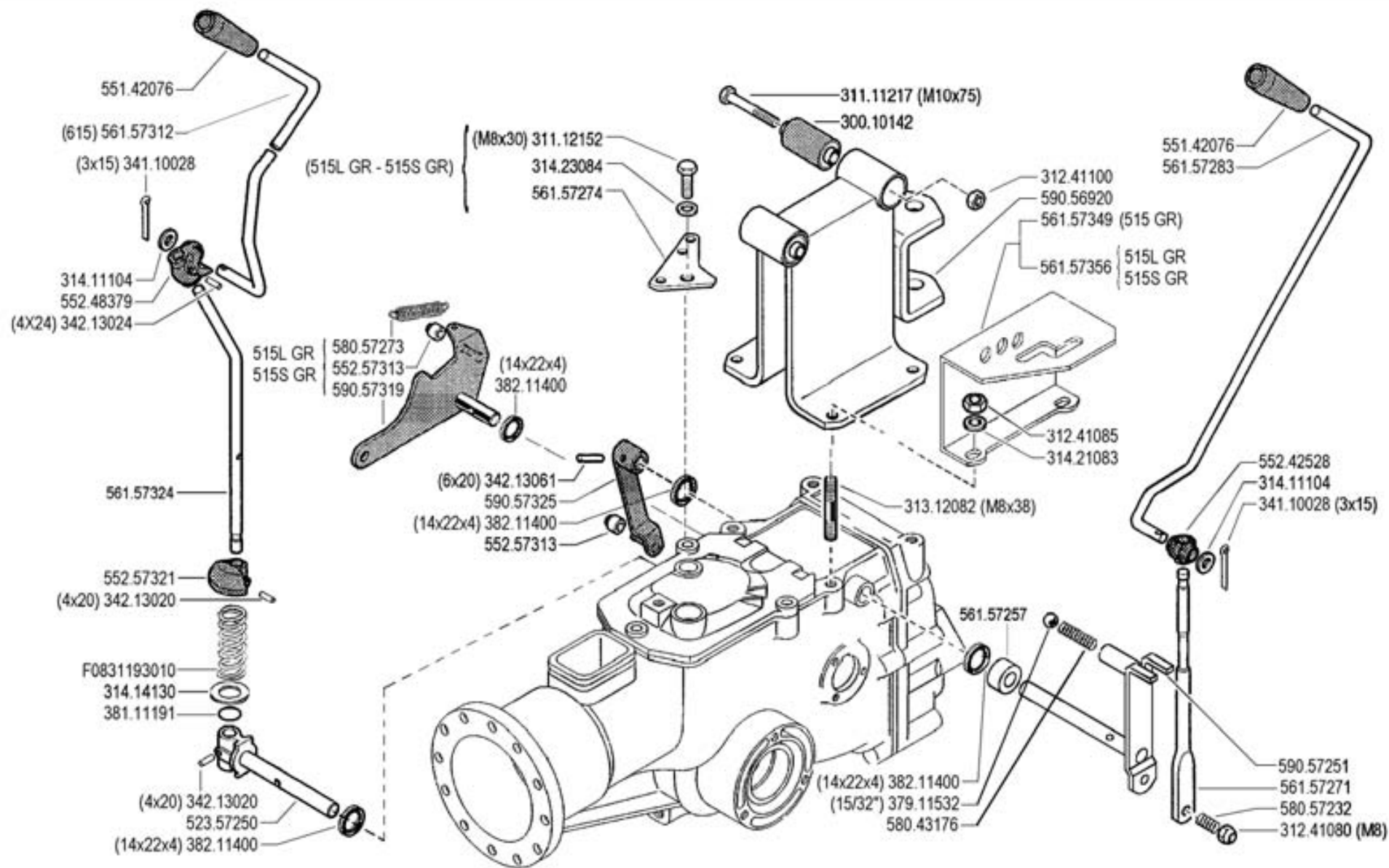

FERRARI

500 serie GRIFON

COMANDI (515 GR - 515L GR - 515S GR)

CONTROLS
MANDOS

COMMANDES
ANTRIEBE

DALLA MACCHINA
DE LA MAQUINA
DE LA MACHINE
FROM THE MACHINE
AB DER MASCHINE

N.

J01

Rev.

0

09/2004

2/2004

Pos.	Code	Q.ty	Description	Notes
58057273	58057273	1	SPRING	
59056920	59056920	1	SUPPORT	
59057251	59057251	1	GEAR LEVER	
59057319	59057319	1	LEVER	
59057325	59057325	1	LEVER	
F0831193	F0831193010	1	SPRING DM.15X70	

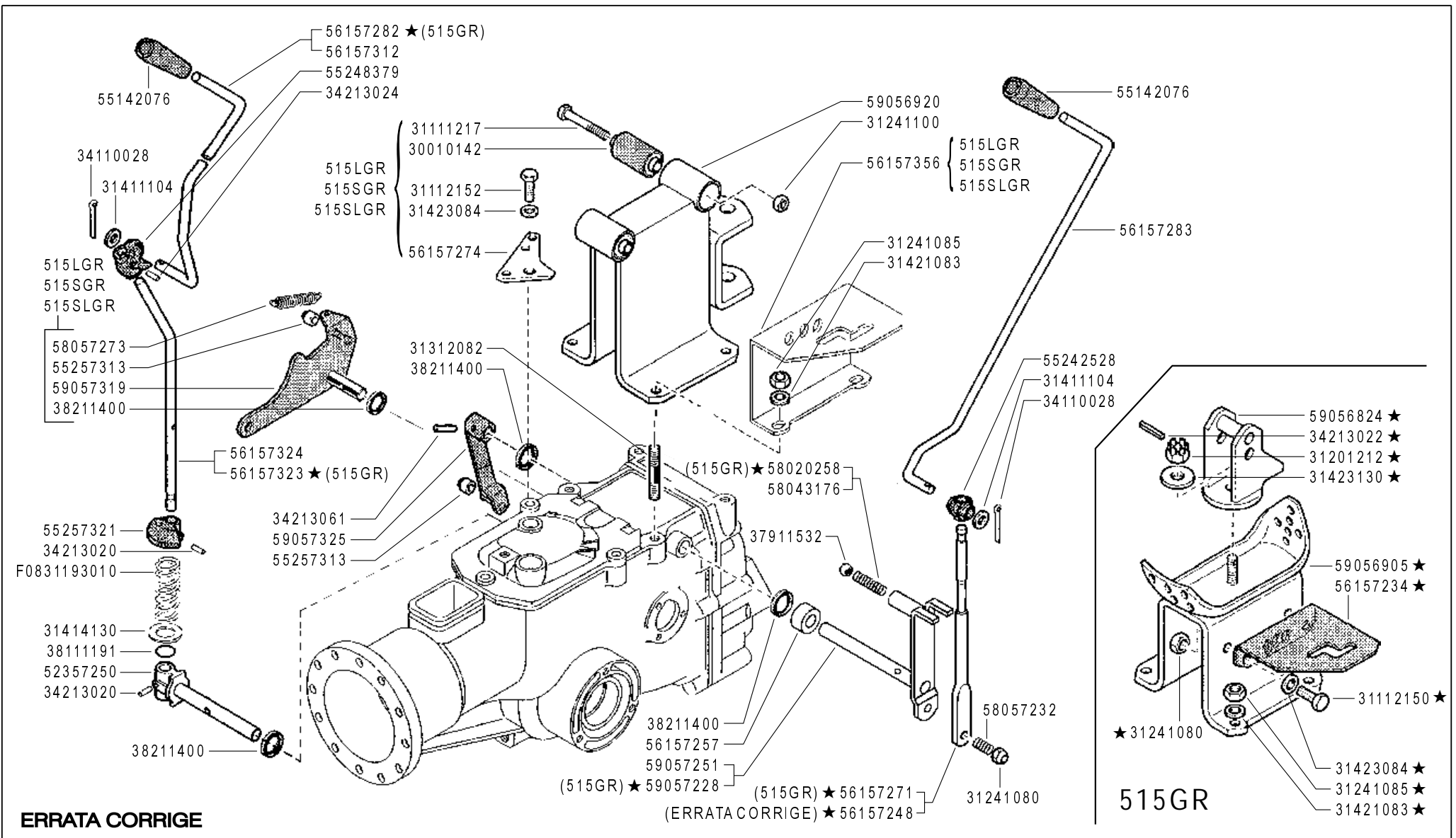

ERRATA CORRIGE

	<h1>500 serie GRIFON</h1>	COMANDI (515GR - 515L GR - 515S GR - 515SL GR ★)		DALLA MACCHINA DE LA MAQUINA DE LA MACHINE FROM THE MACHINE AB DER MASCHINE	<table border="1"> <tr> <td>Rev.</td> <td>1</td> </tr> </table>	Rev.	1
		Rev.	1				
CONTROLS MANDOS	COMMANDES ANTRIEBE	★ N.	825532 (515GR)	J01 02/2009			

Pos.	Code	Q.ty	Description	Notes
30010142	30010142	1	SILENT-BLOCK 10,2X30X45X49	
31111217	31111217	1	SCREW TE M10X75 UNI 5737 8G	
31112150	31112150	1	SCREW TE M8X20 UNI 5739 8G	
31112152	31112152	1	SCREW TE M8X30 UNI 5739 8G	
31201212	31201212	1	NUT M12	
31241080	31241080	1	SELFLOCK NUT M8	
31241085	31241085	1	SELFLOCK NUT M8 6S	
31241100	31241100	1	SELFLOCK NUT M10 6S	
31312082	31312082	1	STUD BOLT M8X38X14X20	
31411104	31411104	1	WASHER 10,5x18	
31414130	31414130	1	WASHER 13	
31421083	31421083	1	WASHER	
31423084	31423084	1	SPRING WASHER 8,4	
31423130	31423130	1	SPRING WASHER 13	
34110028	34110028	1	SPLIT PIN	
34213020	34213020	1	ROLL PIN	
34213022	34213022	1	ROLL PIN	
34213024	34213024	1	ROLL PIN	
34213061	34213061	1	ROLL PIN	
37911532	37911532	1	BALL 15/32	
38111191	38111191	1	O-RING 115 (11,91X2,62)	
38111400	38111400	1	O-RING 2056 (14,00X1,78)	
38211400	38211400	1	OIL SEAL 14X22X4	
52357250	52357250	1	PIN	
55142076	55142076	1	KNOB	
55242528	55242528	1	JOINT	
55248379	55248379	1	JOINT	
55257313	55257313	1	ROLLER	
55257321	55257321	1	STOP	
56157234	56157234	1	GEAR SELECTOR	
56157248	56157248	1	COMMAND LEVER	
56157257	56157257	1	SPACER	
56157271	56157271	1	COMMAND LEVER	
56157274	56157274	1	SQUARE	

SERIAL
START
825532

CONTROLS

Version: 515GR, 515L GR, 515S GR, 515SL GR

CODE REV

J01_1_67885

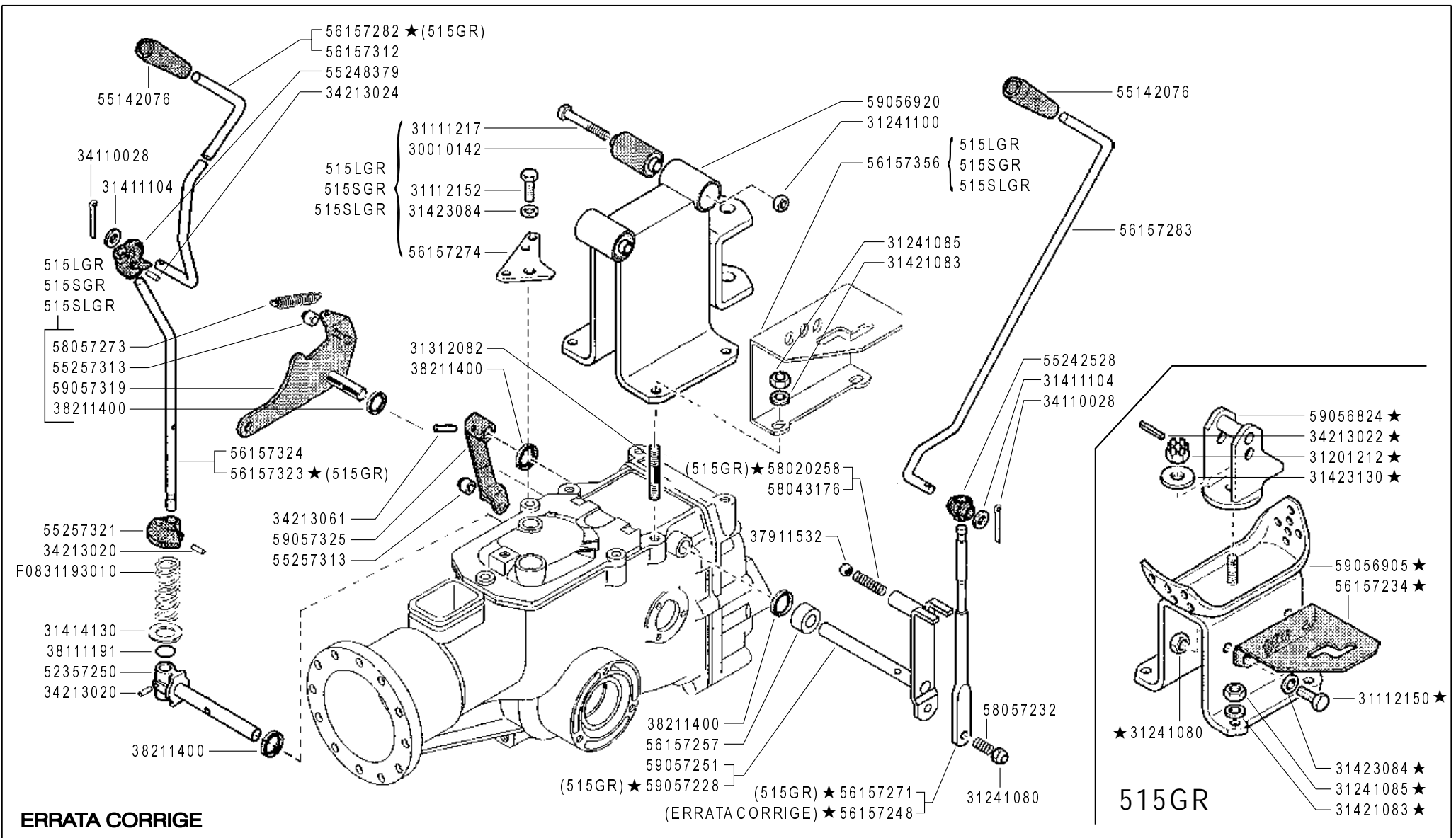

ERRATA CORRIGE

	<h1>500 serie GRIFON</h1>	COMANDI (515GR - 515L GR - 515S GR - 515SL GR ★)		DALLA MACCHINA DE LA MAQUINA DE LA MACHINE FROM THE MACHINE AB DER MASCHINE	<table border="1"> <tr><td> </td></tr> <tr><td> </td></tr> <tr><td> </td></tr> <tr><td> </td></tr> </table>					<h2>J01</h2>	Rev. 1
CONTROLS MANDOS	COMMANDES ANTRIEBE	★ N.	825532 (515GR)	02/2009							

Pos.	Code	Q.ty	Description	Notes
56157282	56157282	1	ROD	
56157283	56157283	1	GEARSHIFT ROD	
56157312	56157312	1	ROD	
56157323	56157323	1	PTO LEVER	
56157324	56157324	1	PTO LEVER	
56157349	56157349	1	SELECTOR	
56157356	56157356	1	GEAR SELECTOR	
58020258	58020258	1	SPRING	
58043176	58043176	1	SPRING	
58057232	58057232	1	SPRING	
58057273	58057273	1	SPRING	
59056824	59056824	1	SUPPORTO PIANTONE 710 PS	
59056905	59056905	1	SUMP	
59056920	59056920	1	SUPPORT	
59057228	59057228	1	GEAR LEVER	
59057251	59057251	1	GEAR LEVER	
59057319	59057319	1	LEVER	
59057325	59057325	1	LEVER	
F0831193	F0831193010	1	SPRING DM.15X70	

SERIAL
START
825532

CONTROLS

Version: 515GR, 515L GR, 515S GR, 515SL GR

CODE REV

J01_1_67885

CONTROLS

SERIAL START 863996

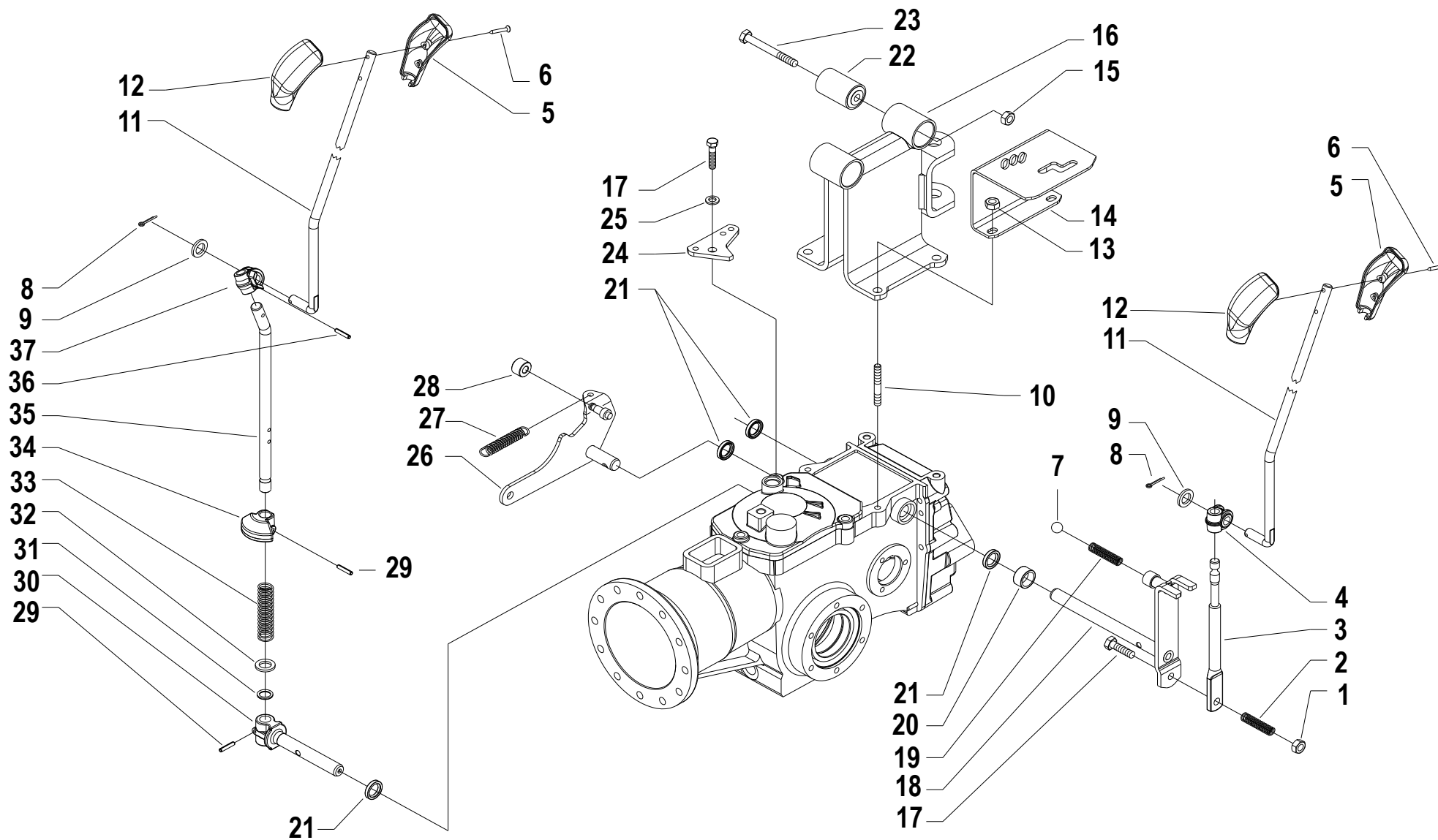

Pos.	Code	Q.ty	Description	Notes
1	31241080	1	SELFLOCK NUT M8	
2	58057232Z	1	SPRING	
3	56157271N	1	COMMAND LEVER	
4	55242528	1	JOINT	
5	55157213	1	GRIP	
6	31100451	1	SCREW 3,5X25	
7	37911532	1	BALL 15/32	
8	34110028	1	SPLIT PIN	
9	31411104	1	WASHER 10,5x18	
10	31312082	1	STUD BOLT M8X38X14X20	
11	56156792N	1	PULL ROD	
12	55157212	1	GRIP	
13	31241084	1	SELFLOCK NUT M8 6S	
14	56156195H	1	GEAR SELECTOR	
15	31241100	1	SELFLOCK NUT M10 6S	
16	59056920	1	SUPPORT	
17	31112152	1	SCREW TE M8X30 UNI 5739 8G	
18	59057251N	1	GEAR LEVER	
19	58043176	1	SPRING	
20	56157257Z	1	SPACER	
21	38211400	1	OIL SEAL 14X22X4	
22	30010142	1	SILENT-BLOCK 10,2X30X45X49	
23	31111217	1	SCREW TE M10X75 UNI 5737 8G	
24	56157274	1	SQUARE	
25	31423084	1	SPRING WASHER 8,4	
26	59057319	1	LEVER	
27	58057273	1	SPRING	
28	55257313	1	ROLLER	
29	34213020	1	ROLL PIN	
30	52357250	1	PIN	
31	38111191	1	O-RING 115 (11,91X2,62)	
32	31414130	1	WASHER 13	
33	F0831193010	1	SPRING DM.15X70	
34	55257321	1	STOP	

SERIAL
START
863996

CONTROLS

CODE REV

J.01.02.A0011_02

CONTROLS

SERIAL START 863996

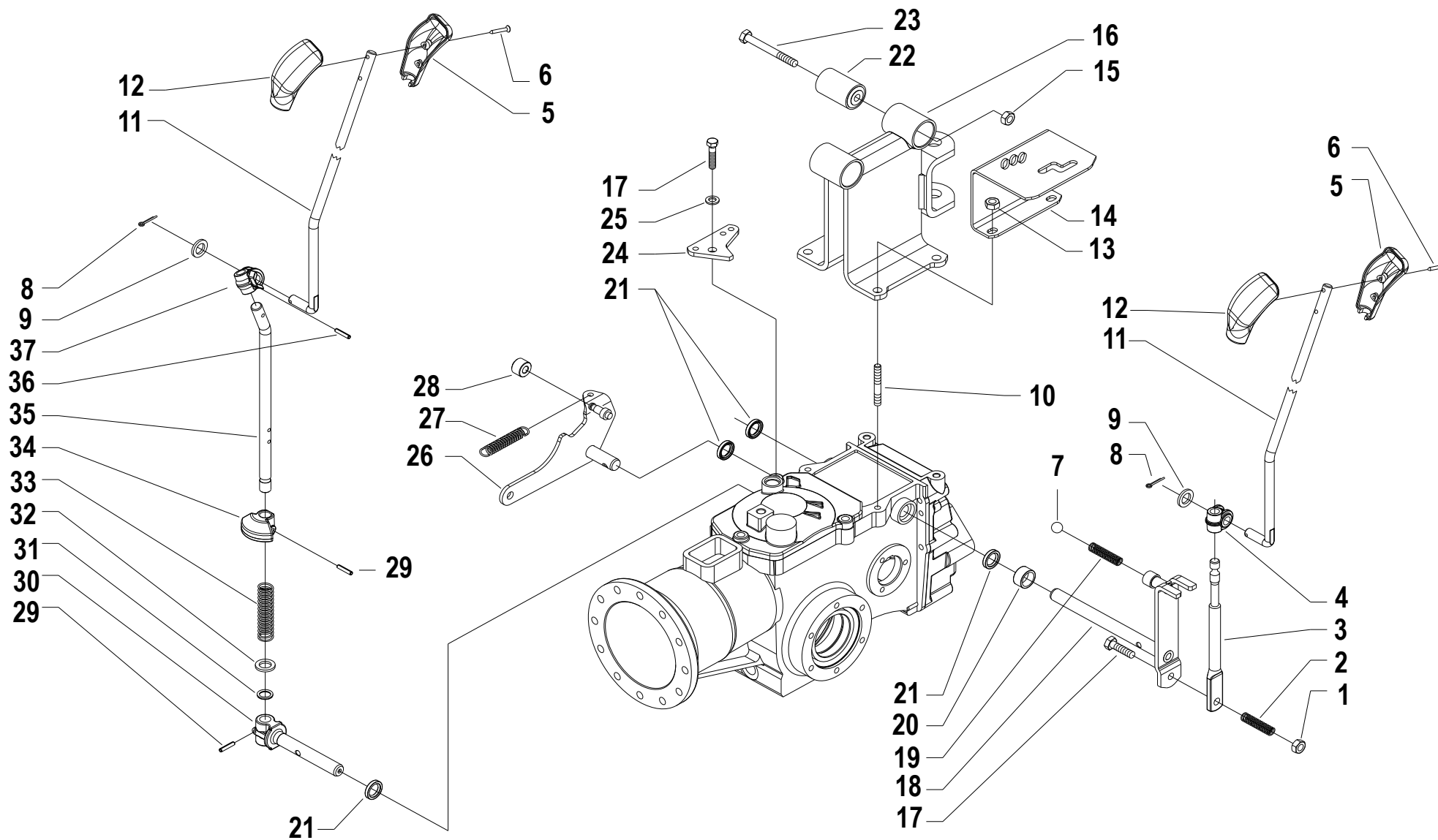

Pos.	Code	Q.ty	Description	Notes
35	56157324N	1	PTO LEVER	
36	34213024	1	ROLL PIN	
37	55248379	1	JOINT	

SERIAL
START
863996

CONTROLS

CODE REV
J.01.02.A0011_02

HANDLEBAR CONTROLS

SERIAL START 863996

J.03.02.A0011_00

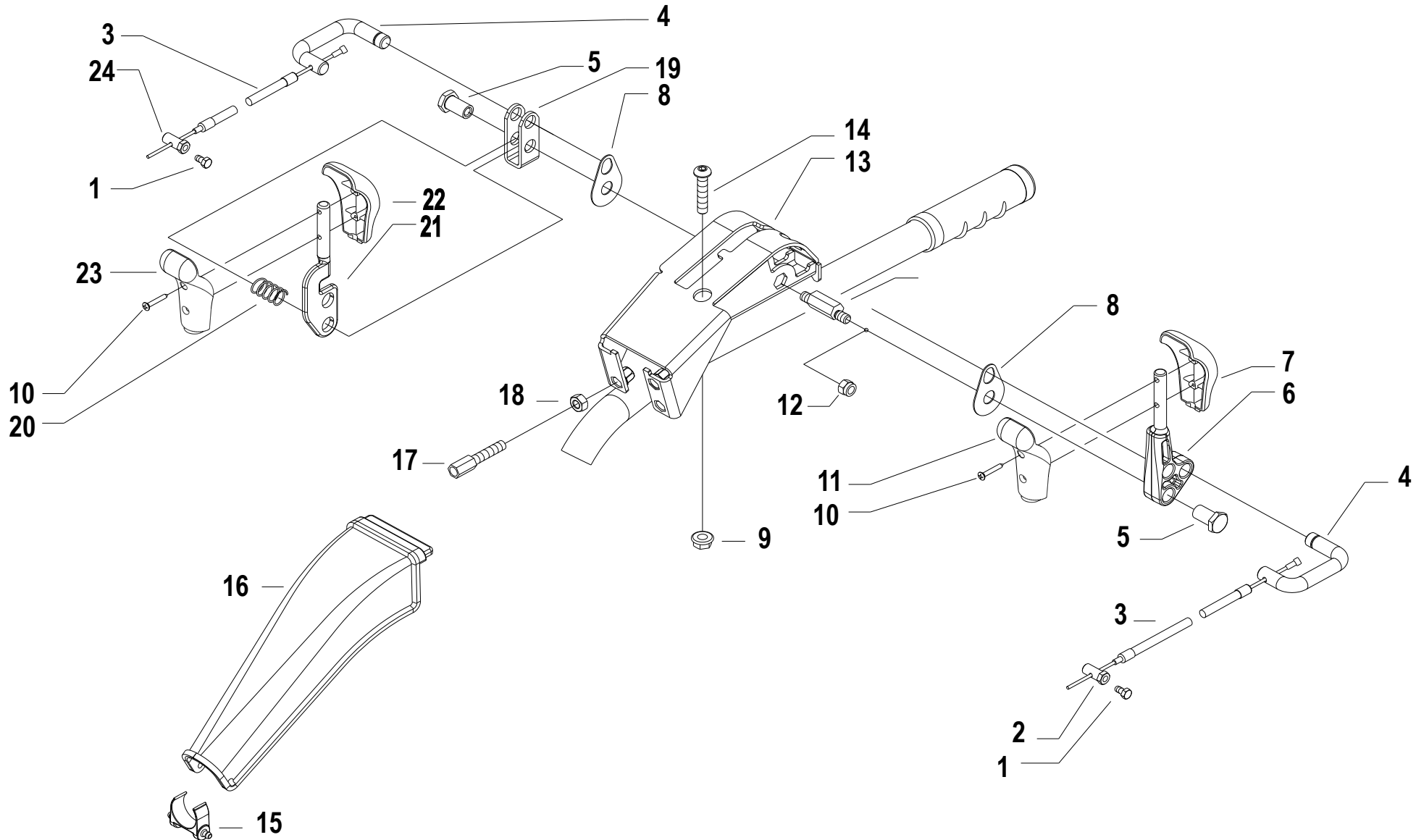

Pos.	Code	Q.ty	Description	Notes
1	31112090	1	SCREW TE M6X16 UNI 5739 8G	
2	56356840Z	1	CLAMPING SCREW	
3	58056848	1	LINE AND SHEATH	
4	56156832Z	1	U BOLT	
5	56148287	1	STUD BOLT	
6	53156860	1	COMMAND LEVER	
7	55157212	1	GRIP	
8	56356833Z	1	SMALL PLATE	
9	31241084	1	SELFLOCK NUT M8 6S	
10	31100451	1	SCREW 3,5X25	
11	55157213	1	GRIP	
12	31241084	1	SELFLOCK NUT M8 6S	
13	59256850	1	SUPPORT	
14	31121020	1	SCREW TBCEI M8X40 ISO7380 10K Z	
15	55256836	1	CROSS MEMBER	
16	55256835	1	PROTECTION COVER	
17	58056595	1	ADJUSTING SCREW	
18	31211080	1	NUT M8	
19	56156859Z	1	FORK	
20	58049830	1	SPRING	
21	52156810Z	1	COMMAND LEVER	
22	55157214	1	GRIP	
23	55157215	1	GRIP	
24	58042200	1	CLAMPING SCREW	

SERIAL
START
863996

HANDLEBAR CONTROLS

CODE REV

J.03.02.A0011_00

	A	B	C
3.50 - 8" (500)	391.13502	394.13502	580.52325
3.50 - 8"	391.13502	394.13502	580.52326
4.00 - 8"	391.14008	394.14008	580.52326
4.0 - 10"	391.14010	394.14010	580.52327
5.0 - 10"	391.15010	394.15010	580.52327
6.5 / 80 - 12"	391.16018	394.16018	F0849044070
21 x 11.00 - 8"	391.13501	TUBELESS	580.52274
20 x 8.00 - 10"	391.18021 (TR)	394.16025	580.52281
20 x 8.00 - 10"	391.18020 (GA)	394.15010	580.52281

924.57794
KIT GEMELLAGGIO PER 4.0-10" / 5.0-10"
TWINNING KIT FOR 4.0-10" / 5.0-10"
JUMELAGE KIT POUR 4.0-10" / 5.0-10"
KIT GEMELOS POR 4.0-10" / 5.0-10"
ZWILLINGSKIT 4.0-10" / 5.0-10"

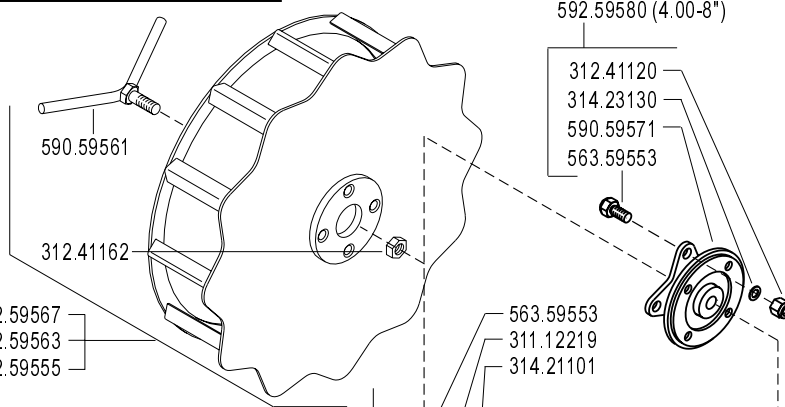

(4.00-8") 592.59567
(4.0-10") 592.59563
(5.0-10") 592.59555

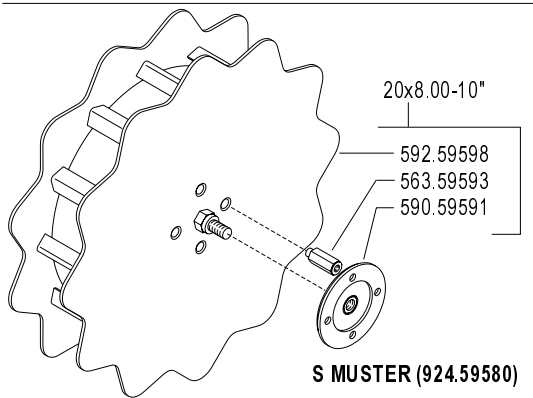

S MUSTER (924.59580)

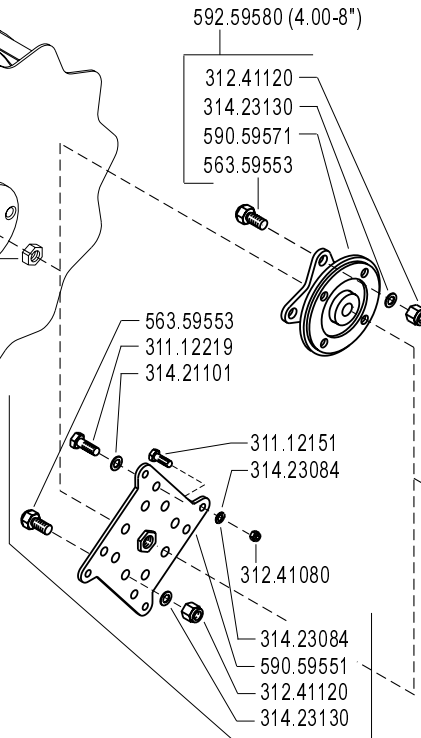

592.59578 (4.0-10" / 5.0-10" / 21x11.00-8")

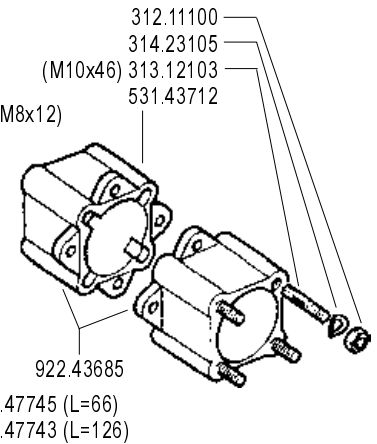
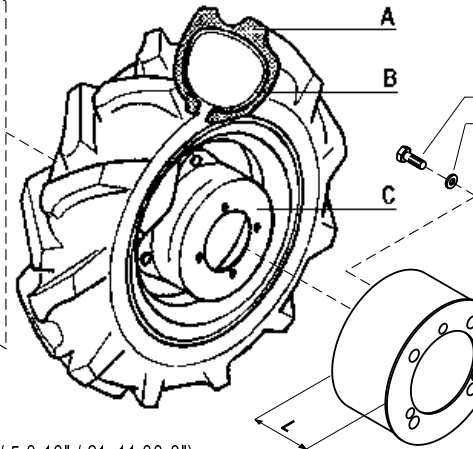
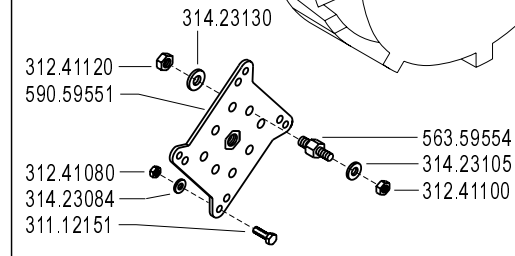

FERRARI

500 serie **GRIFON**

WHEELS
RUEDAS

RUOTE

ROUES
RÄDER

DALLA MACCHINA
DE LA MAQUINA
DE LA MACHINE
FROM THE MACHINE
AB DER MASCHINE

N.

L01 0

09/2004

Rev.

ZENNE

Pos.	Code	Q.ty	Description	Notes
31112149	31112149	1	SCREW TE M8X12 UNI 5739 8G	
31112151	31112151	1	SCREW TE M8X25 UNI 5739 8G	
31112219	31112219	1	SCREW TE M10X25 UNI 5739	
31211100	31211100	1	NUT M10	
31241080	31241080	1	SELFLOCK NUT M8	
31241100	31241100	1	SELFLOCK NUT M10 6S	
31241120	31241120	1	SELFLOCK NUT M12	
31241162	31241162	1	SELFLOCK NUT	
31312103	31312103	1	STUD BOLT M10X46X24X16	
31421101	31421101	1	WASHER	
31423084	31423084	1	SPRING WASHER 8,4	
31423105	31423105	1	SPRING WASHER 10,5	
31423130	31423130	1	SPRING WASHER 13	
39113501	39113501	1	TYRE 21X11.00-8	
39113502	39113502	1	TYRE 3.50-8 2PR	
39114008	39114008	1	TYRE 4.00-8 2PR	
39114010	39114010	1	TYRE 4.0-10 2PR	
39115010	39115010	1	TYRE 5.00-10 2PR	
39116018	39116018	1	TYRE 6.5/80-12 2PR	
39118020	39118020	1	TYRE 20X8.00-10 4PR	
39118021	39118021	1	COVER	
39413502	39413502	1	INNER TUBE	
39414008	39414008	1	INNER TUBE	
39414010	39414010	1	INNER TUBE	
39415010	39415010	1	INNER TUBE	
39416018	39416018	1	INNER TUBE	
39416025	39416025	1	INNER TUBE	
53143712	53143712	1	SPACER	
56359553	56359553	1	PIN	
56359554	56359554	1	PIN	
56359593	56359593	1	DRIVING PIN	
58052274	58052274	1	RIM	
58052281	58052281	1	RIM	
58052325	58052325	1	RIM	

SERIAL

WHEELS

CODE REV

L01_0_23182

	A	B	C
3.50 - 8" (500)	391.13502	394.13502	580.52325
3.50 - 8"	391.13502	394.13502	580.52326
4.00 - 8"	391.14008	394.14008	580.52326
4.0 - 10"	391.14010	394.14010	580.52327
5.0 - 10"	391.15010	394.15010	580.52327
6.5 / 80 - 12"	391.16018	394.16018	F0849044070
21 x 11.00 - 8"	391.13501	TUBELESS	580.52274
20 x 8.00 - 10"	391.18021 (TR)	394.16025	580.52281
20 x 8.00 - 10"	391.18020 (GA)	394.15010	580.52281

924.57794
KIT GEMELLAGGIO PER 4.0-10" / 5.0-10"
TWINNING KIT FOR 4.0-10" / 5.0-10"
JUMELAGE KIT POUR 4.0-10" / 5.0-10"
KIT GEMELOS POR 4.0-10" / 5.0-10"
ZWILLINGSKIT 4.0-10" / 5.0-10"

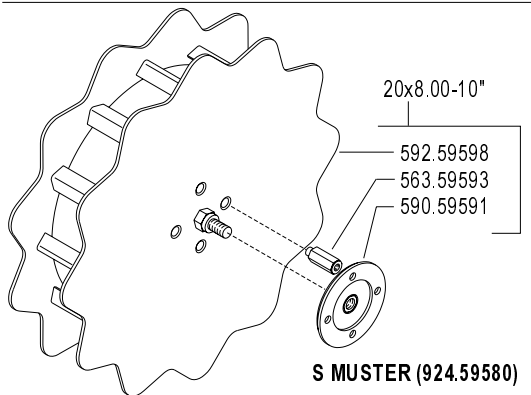
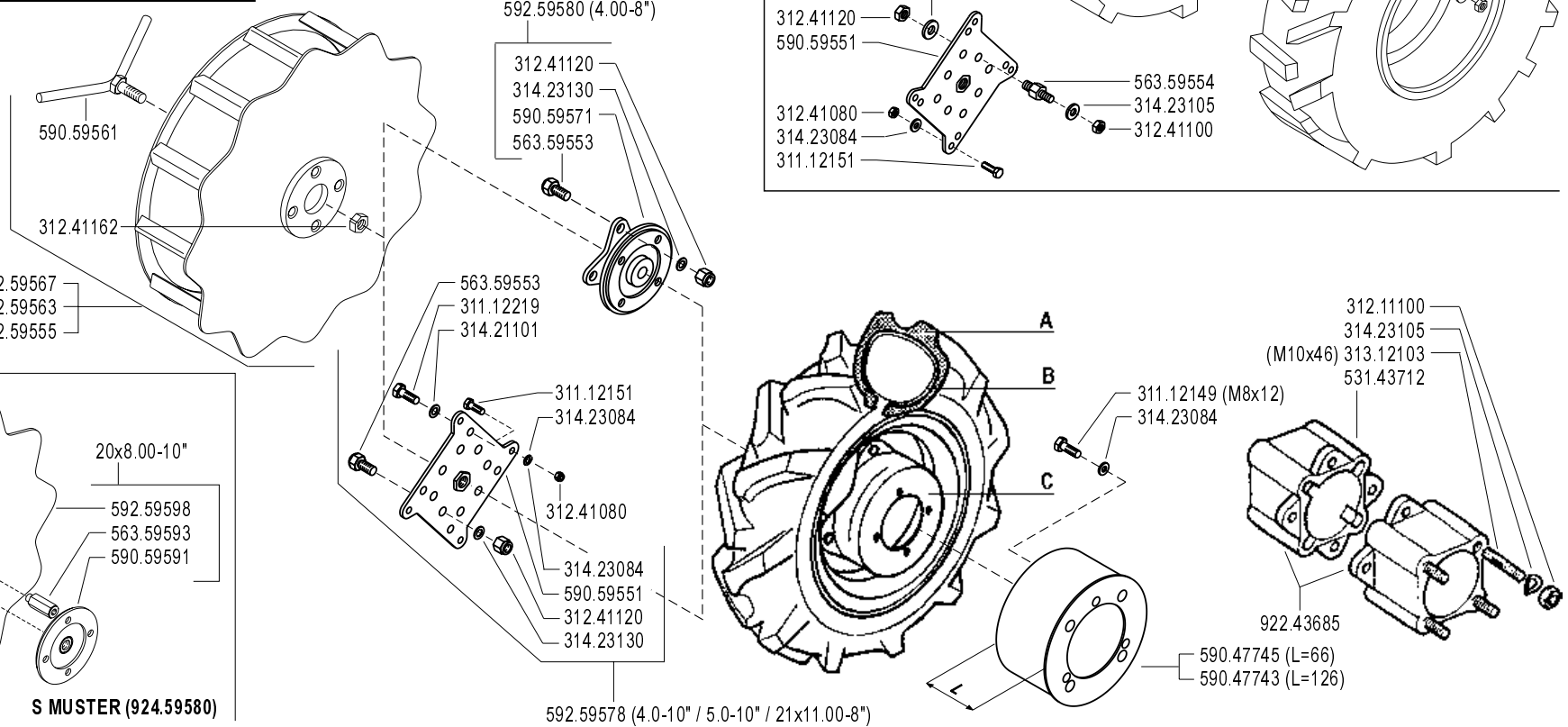

FERRARI

500 serie **GRIFON**

WHEELS
RUEDAS

RUOTE

ROUES
RÄDER

DALLA MACCHINA
DE LA MAQUINA
DE LA MACHINE
FROM THE MACHINE
AB DER MASCHINE

N.

L01

Rev.
0

09/2004

ZENNE

Pos.	Code	Q.ty	Description	Notes
58052326	58052326	1	RIM	
58052327	58052327	1	RIM	
59047743	59047743	1	HUBCOVER	
59047745	59047745	1	HUBCOVER	
59059551	59059551	1	FLANGE	
59059561	59059561	1	SCREW	
59059571	59059571	1	FLANGE	
59059591	59059591	1	SPACER	
59259555	59259555	1	SUPER-BITE WHEEL X 5.00-10	
59259563	59259563	1	WHEEL	
59259567	59259567	1	WHEEL	
59259578	59259578	1	FLANGE KIT	
59259580	59259580	1	FLANGE KIT	
59259598	59259598	1	WHEEL	
92243685	92243685	1	PAIR WHEEL SPACERS 6 CM	
92457794	92457794	1	ADAPTOR PLATES 10 WHEELS (PAIR)	
92459580	92459580	1	COPPIA R.MARGHER.20X8.0-10 FER	
F0849044	F0849044070	1	WHEEL DISC	

	A	B	C
3.50 - 8" (500)	39113502	39413502	58052325
3.50 - 8"	39113502	39413502	58052326
4.00 - 8"	39114008	39414008	58052326
4.0 - 10"	39114010	39414010	58052327
5.0 - 10"	39115010	39415010	58052327
6.5 / 8.0 - 12"	39116018	39416018	F0849044070
21 x 11.00 - 8"	39113501	TUBELESS	58052274
20 x 8.00 - 10"	39118021 (TR)	39416025	58052281
20 x 8.00 - 10"	39118020 (GA)	39415010	58052280 (S MUSTER)

924.57794
KIT GEMELLAGGIO PER 4.0-10" / 5.0-10"
TWINNING KIT FOR 4.0-10" / 5.0-10"
JUMELAGE KIT POUR 4.0-10" / 5.0-10"
KIT GEMELOS POR 4.0-10" / 5.0-10"
ZWILLINGSKIT 4.0-10" / 5.0-10"

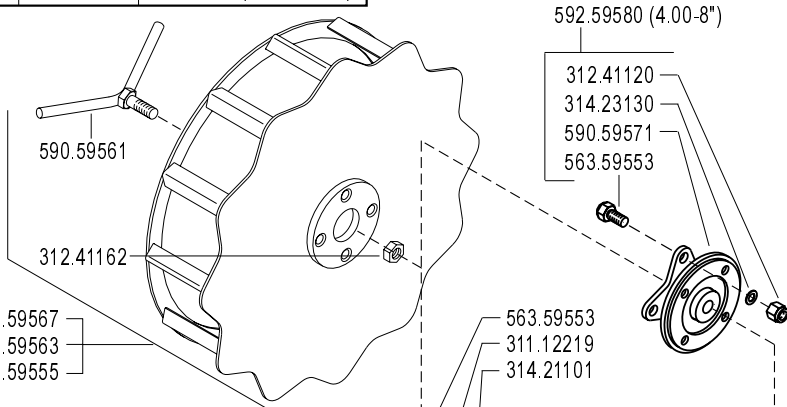
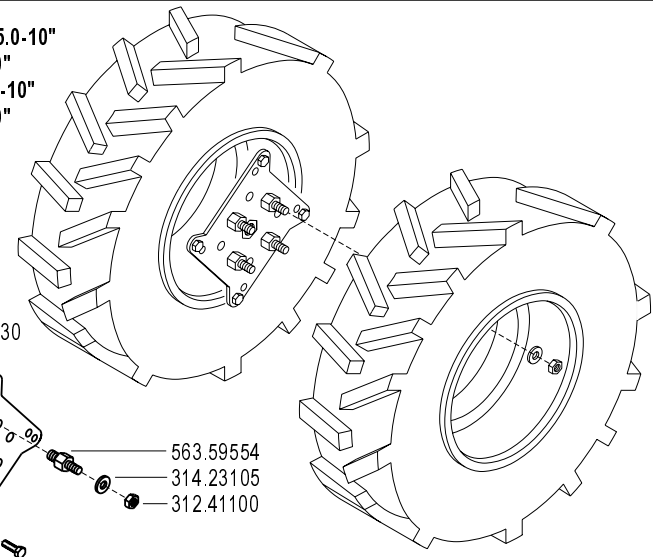

(4.00-8") 592.59567
(4.0-10") 592.59563
(5.0-10") 592.59555

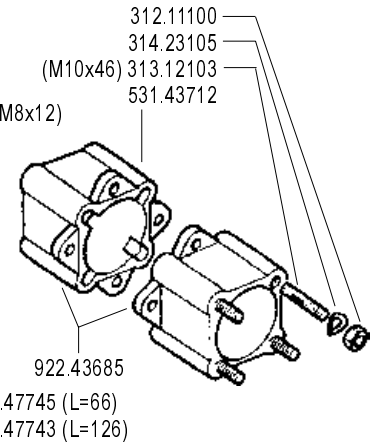
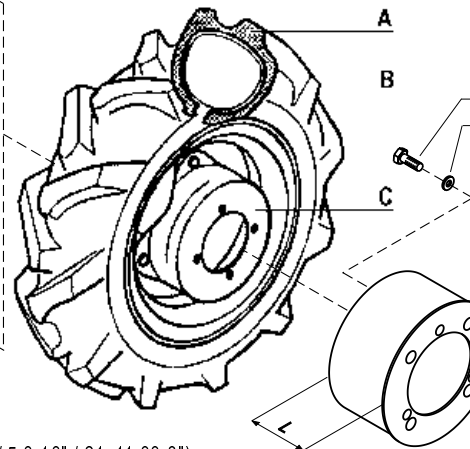
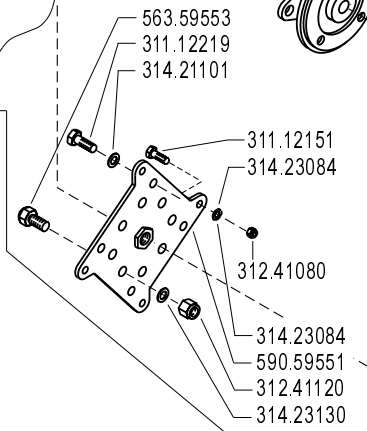
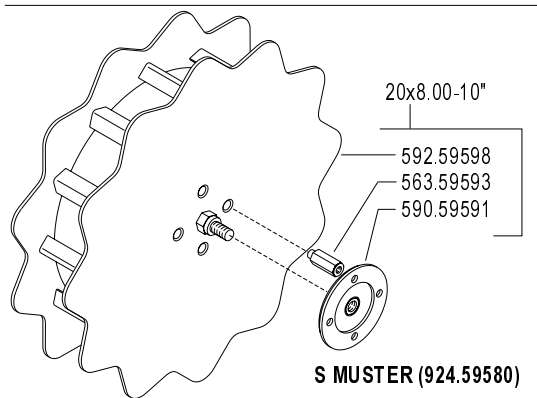

592.59578 (4.0-10" / 5.0-10" / 21x11.00-8")

FERRARI

500 serie **GRIFON**

WHEELS
RUEDAS

RUOTE

ROUES
RÄDER

DALLA MACCHINA
DE LA MAQUINA
DE LA MACHINE
FROM THE MACHINE
AB DER MASCHINE

ERRATA CORRIGE

N.

L01

10/2004

Rev. 1

ZENNE

Pos.	Code	Q.ty	Description	Notes
31112149	31112149	0	SCREW TE M8X12 UNI 5739 8G	
31112151	31112151	0	SCREW TE M8X25 UNI 5739 8G	
31112219	31112219	0	SCREW TE M10X25 UNI 5739	
31211100	31211100	0	NUT M10	
31241080	31241080	0	SELFLOCK NUT M8	
31241100	31241100	0	SELFLOCK NUT M10 6S	
31241120	31241120	0	SELFLOCK NUT M12	
31241162	31241162	0	SELFLOCK NUT	
31312103	31312103	0	STUD BOLT M10X46X24X16	
31421101	31421101	0	WASHER	
31423084	31423084	0	SPRING WASHER 8,4	
31423105	31423105	0	SPRING WASHER 10,5	
31423130	31423130	0	SPRING WASHER 13	
39113501	39113501	0	TYRE 21X11.00-8	
39113502	39113502	0	TYRE 3.50-8 2PR	
39114008	39114008	0	TYRE 4.00-8 2PR	
39114010	39114010	0	TYRE 4.0-10 2PR	
39115010	39115010	0	TYRE 5.00-10 2PR	
39116018	39116018	0	TYRE 6.5/80-12 2PR	
39118020	39118020	0	TYRE 20X8.00-10 4PR	
39118021	39118021	0	COVER	
39413502	39413502	0	INNER TUBE	
39414008	39414008	0	INNER TUBE	
39414010	39414010	0	INNER TUBE	
39415010	39415010	0	INNER TUBE	
39416018	39416018	0	INNER TUBE	
39416025	39416025	0	INNER TUBE	
53143712	53143712	0	SPACER	
56359553	56359553	0	PIN	
56359554	56359554	0	PIN	
56359593	56359593	0	DRIVING PIN	
58052274	58052274	0	RIM	
58052280	58052280	1	RIM	
58052281	58052281	0	RIM	

SERIAL

WHEELS

CODE REV

L01_1_27708

	A	B	C
3.50 - 8" (500)	39113502	39413502	58052325
3.50 - 8"	39113502	39413502	58052326
4.00 - 8"	39114008	39414008	58052326
4.0 - 10"	39114010	39414010	58052327
5.0 - 10"	39115010	39415010	58052327
6.5 / 8.0 - 12"	39116018	39416018	F0849044070
21 x 11.00 - 8"	39113501	TUBELESS	58052274
20 x 8.00 - 10"	39118021 (TR)	39416025	58052281
20 x 8.00 - 10"	39118020 (GA)	39415010	58052280 (S MUSTER)

924.57794
KIT GEMELLAGGIO PER 4.0-10" / 5.0-10"
TWINNING KIT FOR 4.0-10" / 5.0-10"
JUMELAGE KIT POUR 4.0-10" / 5.0-10"
KIT GEMELOS POR 4.0-10" / 5.0-10"
ZWILLINGSKIT 4.0-10" / 5.0-10"

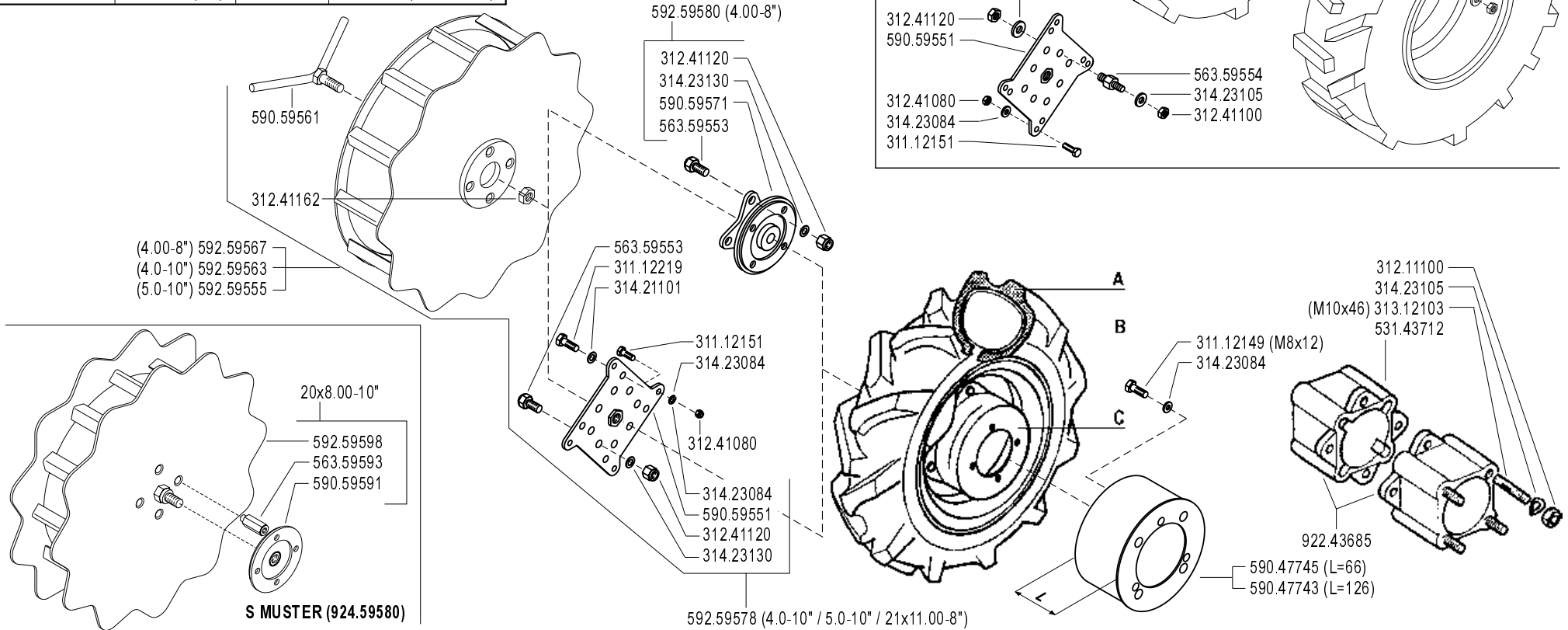

FERRARI

500 serie **GRIFON**

WHEELS
RUEDAS

RUOTE

ROUES
RÄDER

DALLA MACCHINA
DE LA MAQUINA
DE LA MACHINE
FROM THE MACHINE
AB DER MASCHINE

ERRATA CORRIGE

N.

L01

10/2004

Rev.

1

ZENNE

Pos.	Code	Q.ty	Description	Notes
58052325	58052325	0	RIM	
58052326	58052326	0	RIM	
58052327	58052327	0	RIM	
59047743	59047743	0	HUBCOVER	
59047745	59047745	0	HUBCOVER	
59059551	59059551	0	FLANGE	
59059561	59059561	0	SCREW	
59059571	59059571	0	FLANGE	
59059591	59059591	0	SPACER	
59259555	59259555	0	SUPER-BITE WHEEL X 5.00-10	
59259563	59259563	0	WHEEL	
59259567	59259567	0	WHEEL	
59259578	59259578	0	FLANGE KIT	
59259580	59259580	0	FLANGE KIT	
59259598	59259598	0	WHEEL	
92243685	92243685	0	PAIR WHEEL SPACERS 6 CM	
92457794	92457794	0	ADAPTOR PLATES 10 WHEELS (PAIR)	
92459580	92459580	0	COPPIA R.MARGHER.20X8.0-10 FER	
F0849044	F0849044070	0	WHEEL DISC	

	A	B	C
3.50 - 8" (500)	39113502	39413502	58052325
3.50 - 8"	39113502	39413502	58052326
4.00 - 8"	39114008	39414008	58052326
4.0 - 10"	39114010	39414010	58052327
4.0 - 10"	39114010	39414010	58052289 (FIX) ★
5.0 - 10"	39115010	39415010	58052327
5.0 - 10"	39115010	39415010	58052289 (FIX) ★
6.5 / 8.0 - 12"	39116018	39416018	F0849044070
21 x 11.00 - 8"	39113501	TUBELESS	58052274
20 x 8.00 - 10"	39118021 (TR)	39416025	58052281
20 x 8.00 - 10"	39118020 (GA)	39415010	58052280 (S MUSTER)
16 x 6.50 - 8"	39111608	39411608	58052297 ★

92457794

KIT GEMELLAGGIO PER 4.0-10" / 5.0-10"
 TWINNING KIT FOR 4.0-10" / 5.0-10"
 JUMELAGE KIT POUR 4.0-10" / 5.0-10"
 KIT GEMELOS POR 4.0-10" / 5.0-10"
 ZWILLINGSKIT 4.0-10" / 5.0-10"

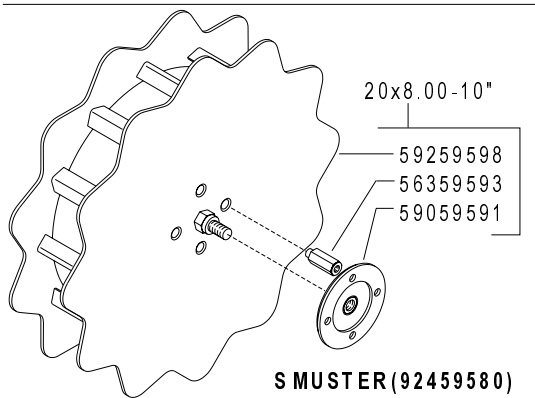
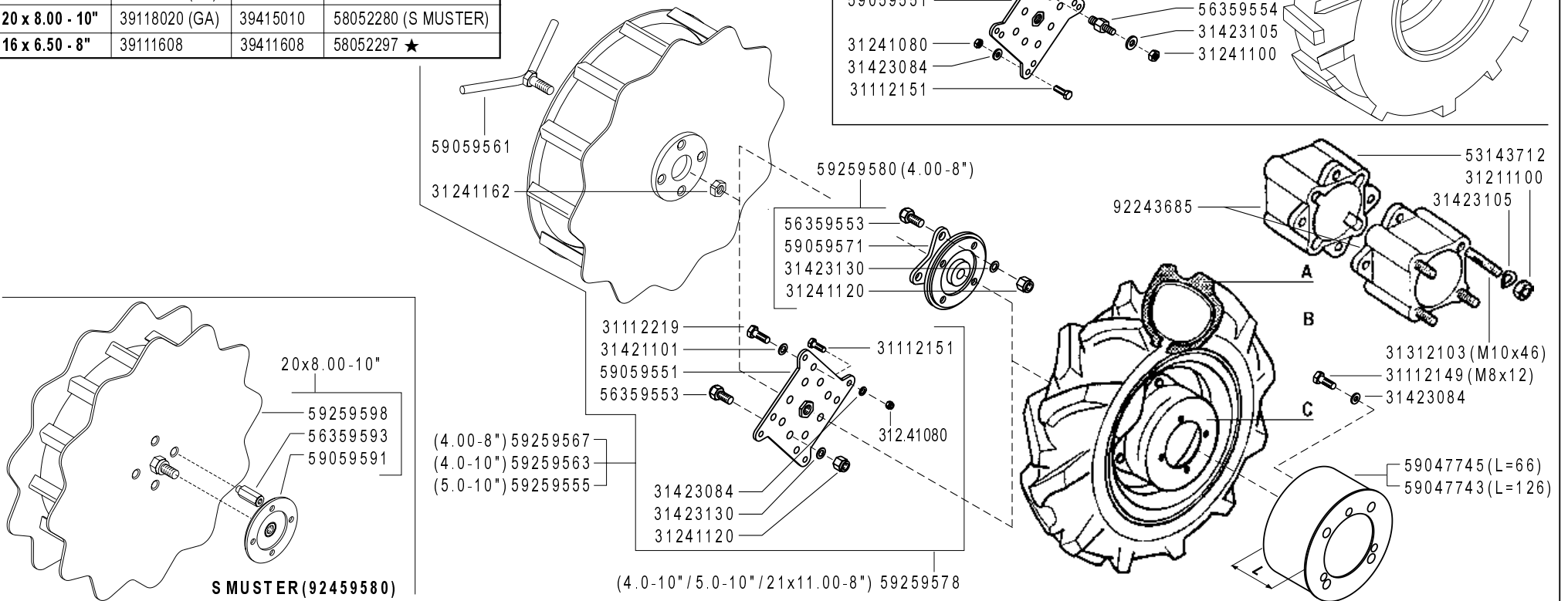

FERRARI

500 serie GRIFON

WHEELS
RUEDAS

RUOTE

ROUES
RÄDER

DALLA MACCHINA
DE LA MAQUINA
DE LA MACHINE
FROM THE MACHINE
AB DER MASCHINE

★ N.

AGGIORNAMENTO
REVISION
MISE A JOUR
APLAZAMIENTO
ANPASSUNG

L01

01/2008

Rev. 2

ZENNE

Pos.	Code	Q.ty	Description	Notes
31112149	31112149	1	SCREW TE M8X12 UNI 5739 8G	
31112151	31112151	1	SCREW TE M8X25 UNI 5739 8G	
31112219	31112219	1	SCREW TE M10X25 UNI 5739	
31211100	31211100	1	NUT M10	
31241080	31241080	1	SELFLOCK NUT M8	
31241100	31241100	1	SELFLOCK NUT M10 6S	
31241120	31241120	1	SELFLOCK NUT M12	
31241162	31241162	1	SELFLOCK NUT	
31312103	31312103	1	STUD BOLT M10X46X24X16	
31421101	31421101	1	WASHER	
31423084	31423084	1	SPRING WASHER 8,4	
31423105	31423105	1	SPRING WASHER 10,5	
31423130	31423130	1	SPRING WASHER 13	
39111608	39111608	1	TYRE 16X6.50-8 4PR	
39113501	39113501	1	TYRE 21X11.00-8	
39113502	39113502	1	TYRE 3.50-8 2PR	
39114008	39114008	1	TYRE 4.00-8 2PR	
39114010	39114010	1	TYRE 4.0-10 2PR	
39115010	39115010	1	TYRE 5.00-10 2PR	
39116018	39116018	1	TYRE 6.5/80-12 2PR	
39118020	39118020	1	TYRE 20X8.00-10 4PR	
39118021	39118021	1	COVER	
39411608	39411608	1	INNER TUBE	
39413502	39413502	1	INNER TUBE	
39414008	39414008	1	INNER TUBE	
39414010	39414010	1	INNER TUBE	
39415010	39415010	1	INNER TUBE	
39416018	39416018	1	INNER TUBE	
39416025	39416025	1	INNER TUBE	
53143712	53143712	1	SPACER	
56359553	56359553	1	PIN	
56359554	56359554	1	PIN	
56359593	56359593	1	DRIVING PIN	
58052274	58052274	1	RIM	

SERIAL

WHEELS

CODE REV

L01_2_60486

	A	B	C
3.50 - 8" (500)	39113502	39413502	58052325
3.50 - 8"	39113502	39413502	58052326
4.00 - 8"	39114008	39414008	58052326
4.0 - 10"	39114010	39414010	58052327
4.0 - 10"	39114010	39414010	58052289 (FIX) ★
5.0 - 10"	39115010	39415010	58052327
5.0 - 10"	39115010	39415010	58052289 (FIX) ★
6.5 / 8.0 - 12"	39116018	39416018	F0849044070
21 x 11.00 - 8"	39113501	TUBELESS	58052274
20 x 8.00 - 10"	39118021 (TR)	39416025	58052281
20 x 8.00 - 10"	39118020 (GA)	39415010	58052280 (S MUSTER)
16 x 6.50 - 8"	39111608	39411608	58052297 ★

92457794

KIT GEMELLAGGIO PER 4.0-10" / 5.0-10"
 TWINNING KIT FOR 4.0-10" / 5.0-10"
 JUMELAGE KIT POUR 4.0-10" / 5.0-10"
 KIT GEMELOS POR 4.0-10" / 5.0-10"
 ZWILLINGSKIT 4.0-10" / 5.0-10"

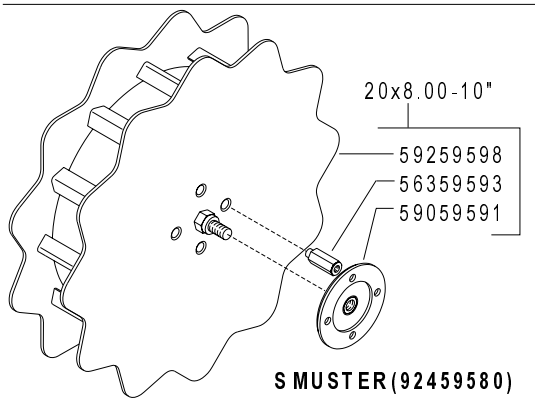
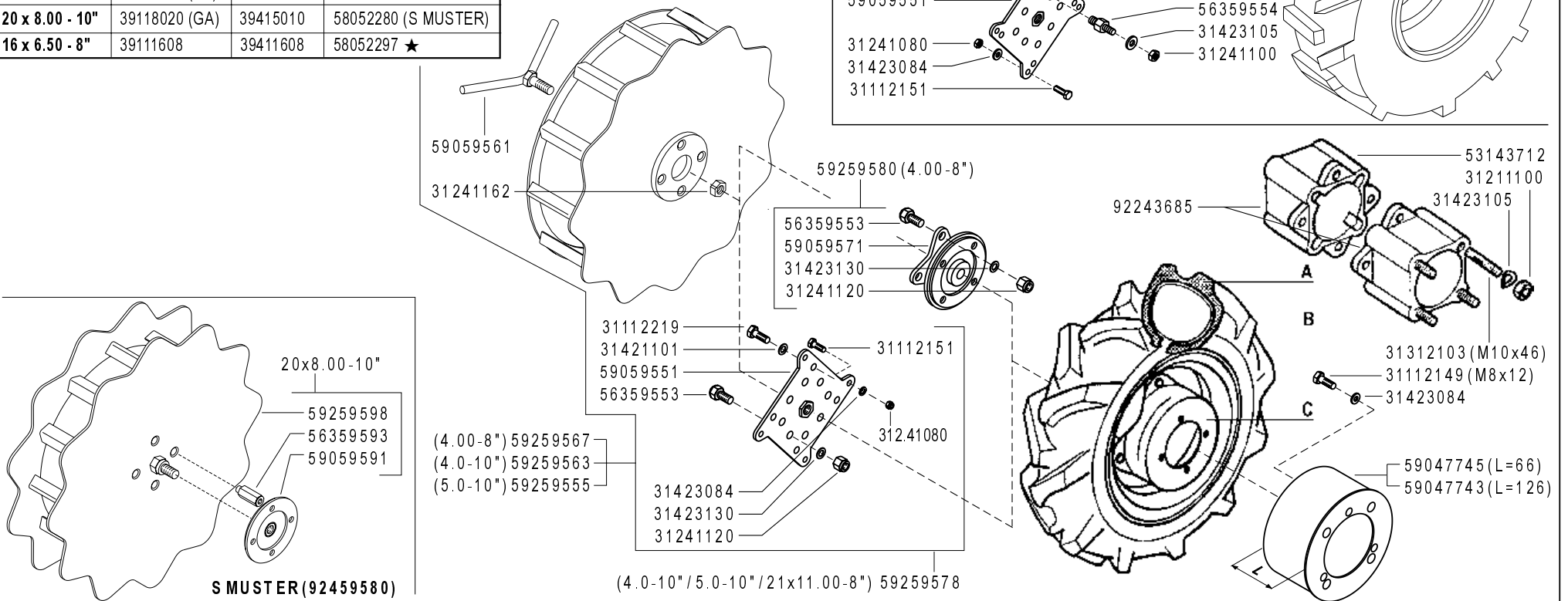

FERRARI 500 serie GRIFON

RUOTE

WHEELS

RUEDAS

ROUES

RÄDER

DALLA MACCHINA
 DE LA MAQUINA
 DE LA MACHINE
 FROM THE MACHINE
 AB DER MASCHINE

★ N.

AGGIORNAMENTO

REVISION

MISE A JOUR

APLAZAMIENTO

ANPASSUNG

Rev. **L01** 2

01/2008

Pos.	Code	Q.ty	Description	Notes
58052280	58052280	1	RIM	
58052281	58052281	1	RIM	
58052289	58052289	1	RIM	
58052297	58052297	1	RIM	
58052325	58052325	1	RIM	
58052326	58052326	1	RIM	
58052327	58052327	1	RIM	
59047743	59047743	1	HUBCOVER	
59047745	59047745	1	HUBCOVER	
59059551	59059551	1	FLANGE	
59059561	59059561	1	SCREW	
59059571	59059571	1	FLANGE	
59059591	59059591	1	SPACER	
59259555	59259555	1	SUPER-BITE WHEEL X 5.00-10	
59259563	59259563	1	WHEEL	
59259567	59259567	1	WHEEL	
59259578	59259578	1	FLANGE KIT	
59259580	59259580	1	FLANGE KIT	
59259598	59259598	1	WHEEL	
92243685	92243685	1	PAIR WHEEL SPACERS 6 CM	
92457794	92457794	1	ADAPTOR PLATES 10 WHEELS (PAIR)	
92459580	92459580	1	COPPIA R.MARGHER.20X8.0-10 FER	
F0849044	F0849044070	1	WHEEL DISC	

	A	B	C
3.50 - 8" (500)	39113502	39413502	58043370 ★
3.50 - 8"	39113502	39413502	58043250 ★
4.00 - 8"	39114008	39414008	58043250 ★
4.0 - 10"	39114010	39415010 ★(1)	58048330 ★
5.0 - 10"	39115010	39415010	58048330 ★
6.5 / 80 - 12"	39116018	39416018	58044804 ★
21 x 11.00 - 8"	39113501	TUBELESS	58057795 ★
20 x 8.00 - 10"	39118021 (TR)	39416025	58057799 ★
20 x 8.00 - 10"	39118020 (GA)	39415010	58057797 ★ (S MUSTER)
16 x 6.50 - 8"	39111665 ★(2)	39411608	58057839 ★

(1) sostituisce 39414010
(2) ERRATA CORRIGE

92457794
KIT GEMELLAGGIO PER 4.0-10" / 5.0-10"
TWINNING KIT FOR 4.0-10" / 5.0-10"
JUMELAGE KIT POUR 4.0-10" / 5.0-10"
KIT GEMELOS POR 4.0-10" / 5.0-10"
ZWILLINGSKIT 4.0-10" / 5.0-10"

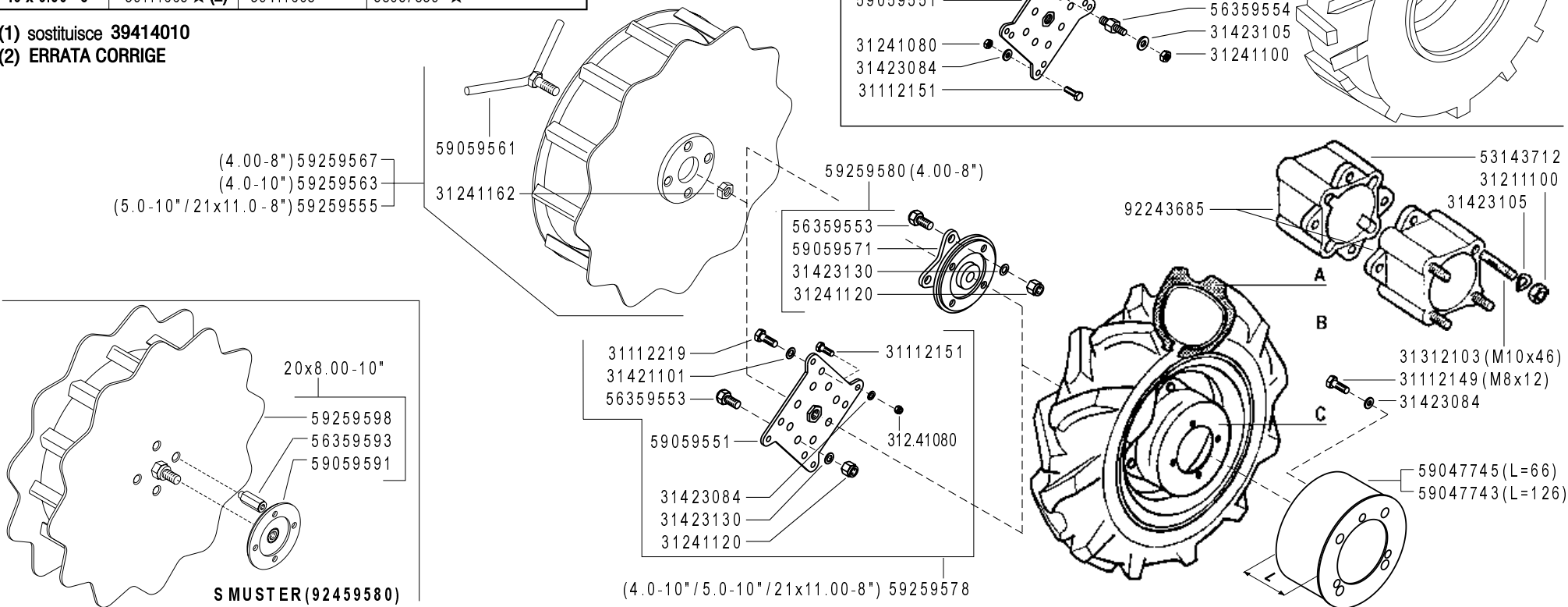

FERRARI

500 serie GRIFON

WHEELS
RUEDAS

RUOTE

ROUES
RÄDER

DALLA MACCHINA
DE LA MAQUINA
DE LA MACHINE
FROM THE MACHINE
AB DER MASCHINE

★ N.

AGGIORNAMENTO
REVISION
MISE A JOUR
APLAZAMIENTO
ANPASSUNG

L01

06/2010

Rev.
3

ZENNE

Pos.	Code	Q.ty	Description	Notes
31112151	31112151	1	SCREW TE M8X25 UNI 5739 8G	
31112219	31112219	1	SCREW TE M10X25 UNI 5739	
31211100	31211100	1	NUT M10	
31241080	31241080	1	SELFLOCK NUT M8	
31241100	31241100	1	SELFLOCK NUT M10 6S	
31241120	31241120	1	SELFLOCK NUT M12	
31241162	31241162	1	SELFLOCK NUT	
31312103	31312103	1	STUD BOLT M10X46X24X16	
31421101	31421101	1	WASHER	
31423084	31423084	1	SPRING WASHER 8,4	
31423105	31423105	1	SPRING WASHER 10,5	
31423130	31423130	1	SPRING WASHER 13	
39111608	39111608	1	TYRE 16X6.50-8 4PR	
39111665	39111665	1	TYRE 16X6.50-8 4PR	
39113501	39113501	1	TYRE 21X11.00-8	
39113502	39113502	1	TYRE 3.50-8 2PR	
39114008	39114008	1	TYRE 4.00-8 2PR	
39114010	39114010	1	TYRE 4.0-10 2PR	
39115010	39115010	1	TYRE 5.00-10 2PR	
39116018	39116018	1	TYRE 6.5/80-12 2PR	
39118020	39118020	1	TYRE 20X8.00-10 4PR	
39118021	39118021	1	COVER	
39411608	39411608	1	INNER TUBE	
39413502	39413502	1	INNER TUBE	
39414008	39414008	1	INNER TUBE	
39415010	39415010	1	INNER TUBE	
39416018	39416018	1	INNER TUBE	
39416025	39416025	1	INNER TUBE	
53143712	53143712	1	SPACER	
56359553	56359553	1	PIN	
56359554	56359554	1	PIN	
56359593	56359593	1	DRIVING PIN	
58043250	58043250	1	RIM	
58043370	58043370	1	RIM	

SERIAL

WHEELS

CODE REV

L01_3_90714

	A	B	C
3.50 - 8" (500)	39113502	39413502	58043370 ★
3.50 - 8"	39113502	39413502	58043250 ★
4.00 - 8"	39114008	39414008	58043250 ★
4.0 - 10"	39114010	39415010 ★(1)	58048330 ★
5.0 - 10"	39115010	39415010	58048330 ★
6.5 / 80 - 12"	39116018	39416018	58044804 ★
21 x 11.00 - 8"	39113501	TUBELESS	58057795 ★
20 x 8.00 - 10"	39118021 (TR)	39416025	58057799 ★
20 x 8.00 - 10"	39118020 (GA)	39415010	58057797 ★ (S MUSTER)
16 x 6.50 - 8"	39111665 ★(2)	39411608	58057839 ★

(1) sostituisce 39414010
(2) ERRATA CORRIGE

92457794
KIT GEMELLAGGIO PER 4.0-10" / 5.0-10"
TWINNING KIT FOR 4.0-10" / 5.0-10"
JUMELAGE KIT POUR 4.0-10" / 5.0-10"
KIT GEMELOS POR 4.0-10" / 5.0-10"
ZWILLINGSKIT 4.0-10" / 5.0-10"

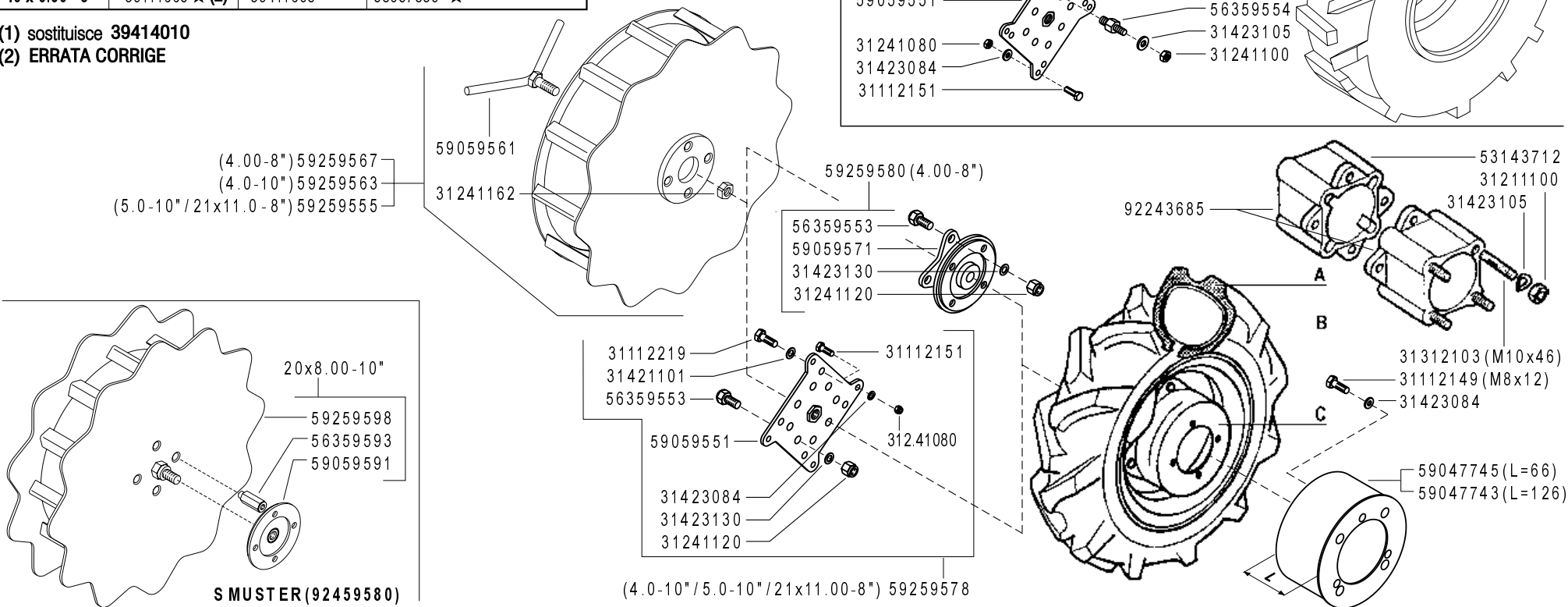

FERRARI

500 serie GRIFON

WHEELS
RUEDAS

RUOTE

ROUES
RÄDER

DALLA MACCHINA
DE LA MAQUINA
DE LA MACHINE
FROM THE MACHINE
AB DER MASCHINE

★ N.

AGGIORNAMENTO
REVISION
MISE A JOUR
APLAZAMIENTO
ANPASSUNG

L01

06/2010

Rev.
3

ZENNE

Pos.	Code	Q.ty	Description	Notes
58044804	58044804	1	RIM	
58048330	58048330	1	RIM	
58057795	58057795	1	RIM	
58057797	58057797	1	RIM	
58057799	58057799	1	RIM	
58057839	58057839	1	RIM	
59047743	59047743	1	HUBCOVER	
59047745	59047745	1	HUBCOVER	
59059551	59059551	1	FLANGE	
59059561	59059561	1	SCREW	
59059571	59059571	1	FLANGE	
59059591	59059591	1	SPACER	
59259555	59259555	1	SUPER-BITE WHEEL X 5.00-10	
59259563	59259563	1	WHEEL	
59259567	59259567	1	WHEEL	
59259578	59259578	1	FLANGE KIT	
59259580	59259580	1	FLANGE KIT	
59259598	59259598	1	WHEEL	
92243685	92243685	1	PAIR WHEEL SPACERS 6 CM	
92457794	92457794	1	ADAPTOR PLATES 10 WHEELS (PAIR)	
92459580	92459580	1	COPPIA R.MARGHER.20X8.0-10 FER	

515 GRIFON

580.52157

S
MULSTER

580.52160

FERRARI

580.52029

515L GRIFON

580.52158

515S GRIFON

580.52159

530 GRIFON

580.52163

520 GRIFON

580.52162

530S GRIFON

580.52164

FERRARI

500 serie GRIFON

STICKERS
ADHESIVOS

ADESIVI

AUTOCOLLANTS
AUFKLEBES

DALLA MACCHINA
DE LA MAQUINA
DE LA MACHINE
FROM THE MACHINE
AB DER MASCHINE

N.

M01

Rev.
0

09/2004

ZENNE

Pos.	Code	Q.ty	Description	Notes
58052029	58052029	1	DECAL	
58052157	58052157	1	DECAL	
58052158	58052158	1	DECAL	
58052159	58052159	1	DECAL	
58052160	58052160	1	DECAL	
58052162	58052162	1	DECAL	
58052163	58052163	1	DECAL	
58052164	58052164	1	DECAL	

500 GRIFON

58052165 ★

FERRARI

58052029

S
MILSTER

58052160

515 GRIFON

58052157

520 GRIFON

58052162

515L GRIFON

58052158

530 GRIFON

58052163

515S GRIFON

58052159

530S GRIFON

58052164

FERRARI

500 serie GRIFON

ADESIVI

STICKERS
ADHESIVOS

AUTOCOLLANTS
AUFKLEBES

DALLA MACCHINA
DE LA MAQUINA
FROM THE MACHINE
AB DER MASCHINE

★ N.

AGGIORNAMENTO

REVISION

MISE A JOUR

APLAZAMIENTO

ANPASSUNG

M01

06/2006

Rev.
1

ZENNE

Pos.	Code	Q.ty	Description	Notes
58052029	58052029	1	DECAL	
58052157	58052157	1	DECAL	
58052158	58052158	1	DECAL	
58052159	58052159	1	DECAL	
58052160	58052160	1	DECAL	
58052162	58052162	1	DECAL	
58052163	58052163	1	DECAL	
58052164	58052164	1	DECAL	
58052165	58052165	1	DECAL	

500 GRIFON

58052165



58052029



58052160

515 GRIFON

58052157

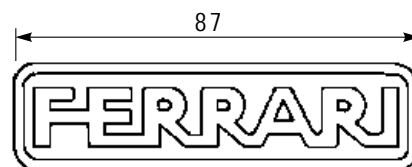

58052019 ★

515L GRIFON

58052158

520 GRIFON

58052162

515S GRIFON

58052159

530 GRIFON

58052163

515SL GRIFON

58052167 ★

530S GRIFON

58052164

FERRARI

500 serie GRIFON

ADESIVI

STICKERS
ADHESIVOS

AUTOCOLLANTS
AUFKLEBES

DALLA MACCHINA
DE LA MAQUINA
DE LA MACHINE
FROM THE MACHINE
AB DER MASCHINE

★ N.

AGGIORNAMENTO
REVISION
MISE A JOUR
APLAZAMIENTO
ANPASSUNG

M01

02/2009

Rev.
2

ZENNE

Pos.	Code	Q.ty	Description	Notes
58052019	58052019	1	DECAL	
58052029	58052029	1	DECAL	
58052157	58052157	1	DECAL	
58052158	58052158	1	DECAL	
58052159	58052159	1	DECAL	
58052160	58052160	1	DECAL	
58052162	58052162	1	DECAL	
58052163	58052163	1	DECAL	
58052164	58052164	1	DECAL	
58052165	58052165	1	DECAL	
58052167	58052167	1	DECAL	

500 GRIFON 58052165

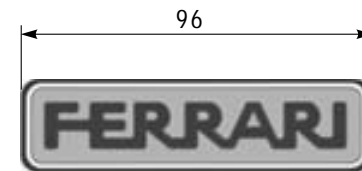

53052175 ★

53052176 ★

515 GRIFON 58052183 ★

530 S

58052190 ★

515L GRIFON 58052184 ★

520 GRIFON 58052187 ★

515S GRIFON 58052185 ★

530 GRIFON 58052188 ★

515SL GRIFON 58052186 ★

530S GRIFON 58052189 ★

FERRARI

500 serie **GRIFON**

STICKERS
ADHESIVOS

ADESIVI

AUTOCOLLANTS
AUFKLEBES

DALLA MACCHINA
DE LA MAQUINA
DE LA MACHINE
FROM THE MACHINE
AB DER MASCHINE

AGGIORNAMENTO

REVISION

MISE A JOUR

APLAZAMIENTO

ANPASSUNG

★N.

M01

Rev.
3

11/2010

ZENNE

Pos.	Code	Q.ty	Description	Notes
53052175	53052175	1	MEDIUM FERRARI BRAND	
53052176	53052176	1	BIG FERRARI BRAND	
58052165	58052165	1	DECAL	
58052183	58052183	1	DECAL	
58052184	58052184	1	DECAL	
58052185	58052185	1	DECAL	
58052186	58052186	1	DECAL	
58052187	58052187	1	DECAL	
58052188	58052188	1	DECAL	
58052189	58052189	1	DECAL	
58052190	58052190	1	DECAL	



580.57698



580.57625



580.57773



580.57774



580.57772



580.57706



580.57767



580.57768



580.57746



580.57747



580.57748



580.46912

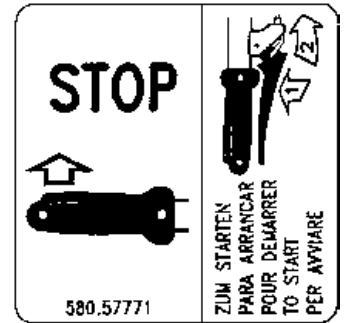

580.57771



580.57676



580.57712

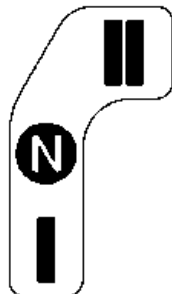

580.57732



580.93089

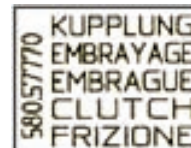

580.57770



580.57722



580.57724

FERRARI

500 serie GRIFON

ADESIVI

STICKERS
ADHESIVOS

AUTOCOLLANTS
AUFKLEBES

DALLA MACCHINA
DE LA MAQUINA
DE LA MACHINE
FROM THE MACHINE
AB DER MASCHINE

N.

Rev.
M02 0

09/2004

ZENNE

Pos.	Code	Q.ty	Description	Notes
58046912	58046912	1	DECAL	
58057625	58057625	1	DECAL	
58057676	58057676	1	DECAL	
58057698	58057698	1	DECAL	
58057706	58057706	1	DECAL	
58057712	58057712	1	DECAL	
58057722	58057722	1	DECAL	
58057724	58057724	1	DECAL	
58057732	58057732	1	DECAL	
58057746	58057746	1	DECAL	
58057747	58057747	1	DECAL	
58057748	58057748	1	DECAL	
58057767	58057767	1	DECAL	
58057768	58057768	1	DECAL	
58057770	58057770	1	DECAL	
58057771	58057771	1	DECAL	
58057772	58057772	1	DECAL	
58057773	58057773	1	DECAL	
58057774	58057774	1	DECAL	
58093089	58093089	1	DECAL	



58057698



58057625



58057773



58057774



58057772



58057706



58057767



58057768



58057746



58057747



58057748



58046912

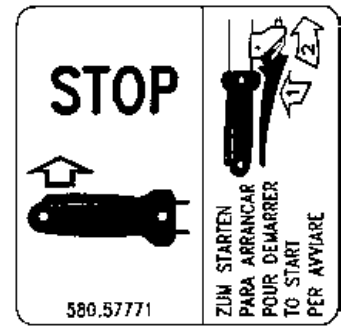

58057771



58057676



58057712



58057678 ★

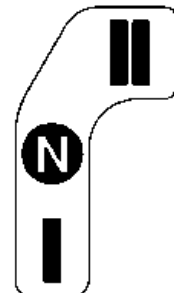

58057732



58093089



58057770



58057722



58057724

FERRARI

500 serie GRIFON

ADESIVI

STICKERS
ADHESIVOS

AUTOCOLLANTS
AUFKLEBES

DALLA MACCHINA
DE LA MAQUINA
DE LA MACHINE
FROM THE MACHINE
AB DER MASCHINE

AGGIORNAMENTO
REVISION
MISE A JOUR
APLAZAMIENTO
ANPASSUNG

★ N.

M02

06/2006

Rev.
1

ZENNE

Pos.	Code	Q.ty	Description	Notes
58046912	58046912	1	DECAL	
58057625	58057625	1	DECAL	
58057676	58057676	1	DECAL	
58057678	58057678	1	DECAL	
58057698	58057698	1	DECAL	
58057706	58057706	1	DECAL	
58057712	58057712	1	DECAL	
58057722	58057722	1	DECAL	
58057724	58057724	1	DECAL	
58057732	58057732	1	DECAL	
58057746	58057746	1	DECAL	
58057747	58057747	1	DECAL	
58057748	58057748	1	DECAL	
58057767	58057767	1	DECAL	
58057768	58057768	1	DECAL	
58057770	58057770	1	DECAL	
58057771	58057771	1	DECAL	
58057772	58057772	1	DECAL	
58057773	58057773	1	DECAL	
58057774	58057774	1	DECAL	
58093089	58093089	1	DECAL	



580.57698



580.57625



580.57773



580.57774



580.57772

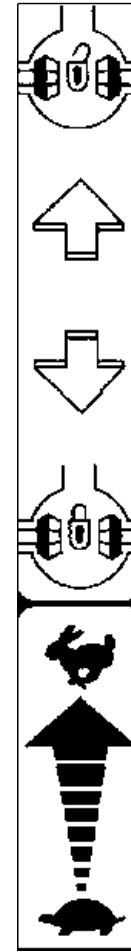

580.57688★



580.57706



580.57767



580.57768

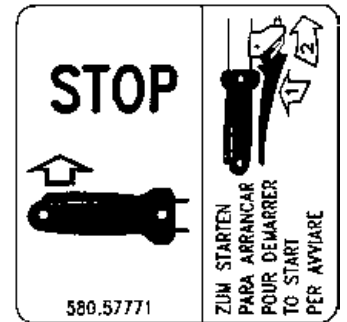

580.57771



580.57676



580.57712



580.57678



580.57722

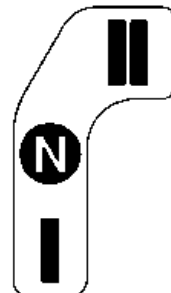

580.57732



580.93089



580.57724



580.57770

FERRARI

500 serie GRIFON

ADESIVI

STICKERS
ADHESIVOS

AUTOCOLLANTS
AUFKLEBES

DALLA MACCHINA
DE LA MAQUINA
DE LA MACHINE
FROM THE MACHINE
AB DER MASCHINE

AGGIORNAMENTO

REVISION

MISE A JOUR

APLAZAMIENTO

ANPASSUNG

★ N.

M02

Rev.
2

02/2009

ZENNE

Pos.	Code	Q.ty	Description	Notes
58046912	58046912	1	DECAL	
58057625	58057625	1	DECAL	
58057676	58057676	1	DECAL	
58057678	58057678	1	DECAL	
58057688	58057688	1	DECAL	
58057698	58057698	1	DECAL	
58057706	58057706	1	DECAL	
58057712	58057712	1	DECAL	
58057722	58057722	1	DECAL	
58057724	58057724	1	DECAL	
58057732	58057732	1	DECAL	
58057746	58057746	1	DECAL	
58057747	58057747	1	DECAL	
58057748	58057748	1	DECAL	
58057767	58057767	1	DECAL	
58057768	58057768	1	DECAL	
58057770	58057770	1	DECAL	
58057771	58057771	1	DECAL	
58057772	58057772	1	DECAL	
58057773	58057773	1	DECAL	
58057774	58057774	1	DECAL	
58093089	58093089	1	DECAL	



58057458



58056864



58056867



58056868



58057746



58057625



58093089



58057747

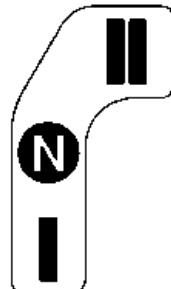

58057732



58057676



58057748



58057773



58057774

ZUM STARTEN
 -KUPPLUNGHEBEL ANHAKEN. (SIEHE) AUFKLEBER AUF DEM LENKHOLM).
 -GASHEBEL ZUR MITTE EINSTELLEN.
 -BENZINHAHN OFFNEN (WENN VORHANDEN).
 -CHOKE SCHLIESSEN (BEI KALTEM MOTOR).
DEN FUSS IN DIE RICHTIGE STELLUNG SETZEN.

ZUM STARTEN
 -DEN SEIL AUF DIE STARTSCHEIBE AUFWICKELN (WENN KEIN REVERSE/STARTER VORHANDEN IST).
 -DER STARTERGRIF IN ENTSCHLOSSENER WEISE ZIEHEN, BEI DEM ELEKTROSTARTER SCHLUSSEL DREHEN.
 -CHOKE OFFNEN.

58046932 (REF.)

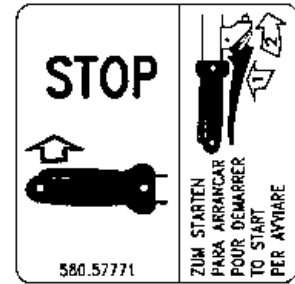

58057771



58057772



58057767



58057768



58057678



58057770



58057722



58057724

FERRARI

500 serie GRIFON

STICKERS
ADHESIVOS

ADESIVI

AUTOCOLLANTS
AUFKLEBES

DALLA MACCHINA
DE LA MAQUINA
DE LA MACHINE
FROM THE MACHINE
AB DER MASCHINE

★ N.

867450 (520-530-S)

863996 (515L-S-SL)

864056 (515)

M02

Rev.
3

11/2010

ZENNE

Pos.	Code	Q.ty	Description	Notes
58046932	58046932	1	DECAL	
58056864	58056864	1	DECAL	
58056867	58056867	1	DECAL	
58056868	58056868	1	DECAL	
58057458	58057458	1	DECAL	
58057625	58057625	1	DECAL	
58057676	58057676	1	DECAL	
58057678	58057678	1	DECAL	
58057722	58057722	1	DECAL	
58057724	58057724	1	DECAL	
58057732	58057732	1	DECAL	
58057746	58057746	1	DECAL	
58057747	58057747	1	DECAL	
58057748	58057748	1	DECAL	
58057767	58057767	1	DECAL	
58057768	58057768	1	DECAL	
58057770	58057770	1	DECAL	
58057771	58057771	1	DECAL	
58057772	58057772	1	DECAL	
58057773	58057773	1	DECAL	
58057774	58057774	1	DECAL	
58093089	58093089	1	DECAL	

SPARE PARTS INSTANCE INDEX





SPARE PARTS INSTANCE INDEX

Code	Parts Table	Pos.	Q.ty	Code	Parts Table	Pos.	Q.ty	Code	Parts Table	Pos.	Q.ty
0	C01_2_67668	0	1	31111090	E01_1_23274	31111090	0	31112149	L01_1_27708	31112149	0
30010103	I01_2_67839	30010103	1		E01_2_67697	31111090	1		L01_2_60486	31112149	1
30010142	J.01.02.A0011_02	22	1	31111091	I01_0_22914	31111091	1	31112150	H01_0_22844	31112150	1
	J01_0_23105	30010142	1		I01_1_32971	31111091	1		J01_1_67885	31112150	1
	J01_1_67885	30010142	1		I01_2_67839	31111091	1	31112151	L01_0_23182	31112151	1
30040001	E.01.02.A0011_03	16	1	31111097	I.01.02.A0011_03	5	1		L01_1_27708	31112151	0
	E.01.02.A0011_04	11			I01_0_22914	31111097	1		L01_2_60486	31112151	1
	E01_0_22534	30040001	1		I01_1_32971	31111097	1		L01_3_90714	31112151	1
	E01_1_23274	30040001	0		I01_2_67839	31111097	1	31112152	J.01.02.A0011_02	17	1
	E01_2_67697	30040001	1	31111151	C01_0_22466	31111151	1		J01_0_23105	31112152	1
30040133	E01_0_22534	30040133	1		C01_1_34043	31111151	1		J01_1_67885	31112152	1
	E01_1_23274	30040133	0	31111216	J01_0_23105	31111216	1	31112153	H01_0_22844	31112153	1
30040133Z	E.01.02.A0011_03	19	1	31111217	J.01.02.A0011_02	23	1		H01_1_59887	31112153	1
	E.01.02.A0011_04	18			J01_1_67885	31111217	1		H01_2_67804	31112153	1
	E01_2_67697	30040133	1	31111229	H.01.02.A0011_03	6	1		I01_0_22914	31112153	1
31100003	D01_0_22506	31100003	1		H01_0_22844	31111229	1		I01_1_32971	31112153	1
	D01_1_27654	31100003	1		H01_1_59887	31111229	1		I01_2_67839	31112153	1
	D01_2_33546	31100003	1		H01_2_67804	31111229	1	31112154	C.01.02.A0011_03	5	1
	D01_3_59819	31100003	1	31112081	C.01.02.A0011_04	10			C.01.02.A0011_04	6	
	D01_4_72864	31100003	1	31112083	E.01.02.A0011_03	3	1		C01_0_22466	31112154	1
31100015	D01_0_22506	31100015	1		E.01.02.A0011_04	3			C01_1_34043	31112154	1
	D01_1_27654	31100015	1	31112085	C.01.02.A0011_03	4	1		C01_2_67668	31112154	1
	D01_2_33546	31100015	1	31112089	I.01.02.A0011_03	1	1	31112165	H.01.02.A0011_03	7	1
	D01_3_59819	31100015	1		I01_0_22914	31112089	1	31112170	H.01.02.A0011_03	31	1
	D01_4_72864	31100015	1		I01_1_32971	31112089	1		H01_1_59887	31112170	1
31100451	H.01.02.A0011_03	4	1		I01_2_67839	31112089	1		H01_2_67804	31112170	1
	J.01.02.A0011_02	6	1	31112090	J.03.02.A0011_00	1	1	31112210	E01_0_22534	31112210	1
	J.03.02.A0011_00	10	1	31112092	I.01.02.A0011_03	11	1		E01_1_23274	31112210	0
31100786	D01_0_22506	31100786	1		I01_0_22914	31112092	1	31112211	F.02.02.A0011_03	24	
31111086	H01_0_22844	31111086	1		I01_1_32971	31112092	1		F02_0_22647	31112211	1
	H01_1_59887	31111086	1		I01_2_67839	31112092	1		F02_1_59847	31112211	1
	H01_2_67804	31111086	1	31112093	C01_2_67668	31112093	1		F02_2_67738	31112211	1
	I01_2_67839	31111086	1	31112147	G01_1_34130	31112147	1	31112213	C.01.02.A0011_03	5	1
31111090	E01_0_22534	31111090	1	31112149	L01_0_23182	31112149	1		C.01.02.A0011_04	6	



SPARE PARTS INSTANCE INDEX

Code	Parts Table	Pos.	Q.ty	Code	Parts Table	Pos.	Q.ty	Code	Parts Table	Pos.	Q.ty
31112213	C01_0_22466	31112213	1	31211080	D01_1_27654	31211080	1	31241080	C01_1_34043	31241080	1
	C01_1_34043	31112213	1		D01_2_33546	31211080	1		C01_2_67668	31241080	1
	C01_2_67668	31112213	1		D01_3_59819	31211080	1		D01_2_33546	31241080	1
31112217	H.01.02.A0011_03	42	1		D01_4_72864	31211080	1		D01_3_59819	31241080	1
	H01_2_67804	31112217	1		H.01.02.A0011_03	29	1		D01_4_72864	31241080	1
	I01_2_67839	31112217	1		H01_0_22844	31211080	1		E.01.02.A0011_03	23	1
31112219	L01_0_23182	31112219	1		H01_1_59887	31211080	1		E01_0_22534	31241080	1
	L01_1_27708	31112219	0		H01_2_67804	31211080	1		E01_1_23274	31241080	0
	L01_2_60486	31112219	1		I.01.02.A0011_03	16	1		E01_2_67697	31241080	1
	L01_3_90714	31112219	1		I01_0_22914	31211080	1		H.01.02.A0011_03	11	1
31112293	H.01.02.A0011_03	22	1		I01_1_32971	31211080	1		H01_0_22844	31241080	1
	H01_0_22844	31112293	1		I01_2_67839	31211080	1		H01_1_59887	31241080	1
	H01_1_59887	31112293	1		J.03.02.A0011_00	18	1		H01_2_67804	31241080	1
	H01_2_67804	31112293	1	31211100	G01_0_22724	31211100	1		I01_0_22914	31241080	1
31112294	H.01.02.A0011_03	41	1		G01_1_34130	31211100	1		I01_1_32971	31241080	1
	H01_2_67804	31112294	1		L01_0_23182	31211100	1		I01_2_67839	31241080	1
31121007	C.01.02.A0011_03	15	1		L01_1_27708	31211100	0		J.01.02.A0011_02	1	1
	C01_1_34043	31121007	1		L01_2_60486	31211100	1		J01_0_23105	31241080	1
	C01_2_67668	31121007	1		L01_3_90714	31211100	1		J01_1_67885	31241080	1
31121020	I.01.02.A0011_03	24	1	31221121	E.01.02.A0011_03	10	1		L01_0_23182	31241080	1
	J.03.02.A0011_00	14	1		E.01.02.A0011_04	10			L01_1_27708	31241080	0
31121024	H.01.02.A0011_03	24	1		E01_0_22534	31221121	1		L01_2_60486	31241080	1
31132562	E.01.02.A0011_03	2	1		E01_1_23274	31221121	0		L01_3_90714	31241080	1
	E.01.02.A0011_04	2			E01_2_67697	31221121	1	31241084	E.01.02.A0011_03	7	1
	E01_0_22534	31132562	1	31241060	C01_2_67668	31241060	1		E.01.02.A0011_04	7	
	E01_1_23274	31132562	0		I.01.02.A0011_03	14	1		J.01.02.A0011_02	13	1
	E01_2_67697	31132562	1		I01_0_22914	31241060	1		J.03.02.A0011_00	9	1
31152084	I01_2_67839	31152084	1		I01_1_32971	31241060	1		J.03.02.A0011_00	12	1
31152103	E.01.02.A0011_03	25	1		I01_2_67839	31241060	1	31241085	E01_0_22534	31241085	1
	E.01.02.A0011_04	21		31241065	C.01.02.A0011_03	3	1		E01_1_23274	31241085	0
	E01_2_67697	31152103	1	31241066	C.01.02.A0011_04	9			E01_2_67697	31241085	1
31201212	J01_1_67885	31201212	1	31241080	C.01.02.A0011_03	7	1		J01_0_23105	31241085	1
31211040	I01_2_67839	31211040	1		C.01.02.A0011_04	8			J01_1_67885	31241085	1
31211080	D01_0_22506	31211080	1		C01_0_22466	31241080	1	31241100	C.01.02.A0011_03	7	1



SPARE PARTS INSTANCE INDEX

Code	Parts Table	Pos.	Q.ty
31241100	C.01.02.A0011_04	8	
	C01_0_22466	31241100	1
	C01_1_34043	31241100	1
	C01_2_67668	31241100	1
	H.01.02.A0011_03	14	1
	H01_0_22844	31241100	1
	H01_2_67804	31241100	1
	I01_2_67839	31241100	1
	J.01.02.A0011_02	15	1
	J01_0_23105	31241100	1
	J01_1_67885	31241100	1
	L01_0_23182	31241100	1
	L01_1_27708	31241100	0
	L01_2_60486	31241100	1
	L01_3_90714	31241100	1
31241120	G01_0_22724	31241120	1
	G01_1_34130	31241120	1
	H.01.02.A0011_03	45	1
	H01_2_67804	31241120	1
	L01_0_23182	31241120	1
	L01_1_27708	31241120	0
	L01_2_60486	31241120	1
	L01_3_90714	31241120	1
31241126	H.01.02.A0011_03	15	1
	H01_0_22844	31241126	1
	H01_1_59887	31241126	1
	H01_2_67804	31241126	1
31241162	L01_0_23182	31241162	1
	L01_1_27708	31241162	0
	L01_2_60486	31241162	1
	L01_3_90714	31241162	1
31312082	E.01.02.A0011_03	13	1
	E.01.02.A0011_04	22	
	E01_0_22534	31312082	1

Code	Parts Table	Pos.	Q.ty
31312082	E01_1_23274	31312082	0
	E01_2_67697	31312082	1
	J.01.02.A0011_02	10	1
	J01_0_23105	31312082	1
	J01_1_67885	31312082	1
31312083	D01_0_22506	31312083	1
	D01_1_27654	31312083	1
	D01_2_33546	31312083	1
	D01_3_59819	31312083	1
	D01_4_72864	31312083	1
31312086	E.01.02.A0011_03	15	1
	E.01.02.A0011_04	12	
	E01_0_22534	31312086	1
	E01_1_23274	31312086	0
	E01_2_67697	31312086	1
31312088	D01_0_22506	31312088	1
	D01_1_27654	31312088	1
	D01_2_33546	31312088	1
	D01_3_59819	31312088	1
	D01_4_72864	31312088	1
31312094	E.01.02.A0011_03	5	1
	E.01.02.A0011_04	5	
	E01_0_22534	31312094	1
	E01_1_23274	31312094	0
	E01_2_67697	31312094	1
31312102	G01_0_22724	31312102	1
	G01_1_34130	31312102	1
31312103	L01_0_23182	31312103	1
	L01_1_27708	31312103	0
	L01_2_60486	31312103	1
	L01_3_90714	31312103	1
31312124	E.01.02.A0011_03	8	1
	E.01.02.A0011_04	8	
	E01_0_22534	31312124	1

Code	Parts Table	Pos.	Q.ty
31312124	E01_1_23274	31312124	0
	E01_2_67697	31312124	1
31312125	E.01.02.A0011_03	8	1
	E.01.02.A0011_04	8	
	E01_0_22534	31312125	1
	E01_1_23274	31312125	0
	E01_2_67697	31312125	1
31411043	H01_0_22844	31411043	1
	H01_1_59887	31411043	1
	H01_2_67804	31411043	1
	I01_2_67839	31411043	1
31411064	C01_2_67668	31411064	1
	I01_0_22914	31411064	1
	I01_1_32971	31411064	1
	I01_2_67839	31411064	1
31411084	C.01.02.A0011_03	6	1
	C.01.02.A0011_04	7	
	C01_0_22466	31411084	1
	C01_1_34043	31411084	1
	C01_2_67668	31411084	1
	I01_0_22914	31411084	1
	I01_1_32971	31411084	1
	I01_2_67839	31411084	1
31411104	C.01.02.A0011_03	6	1
	C.01.02.A0011_04	7	
	C01_0_22466	31411104	1
	C01_1_34043	31411104	1
	C01_2_67668	31411104	1
	J.01.02.A0011_02	9	1
	J01_0_23105	31411104	1
	J01_1_67885	31411104	1
31414130	J.01.02.A0011_02	32	1
	J01_0_23105	31414130	1
	J01_1_67885	31414130	1



SPARE PARTS INSTANCE INDEX

Code	Parts Table	Pos.	Q.ty	Code	Parts Table	Pos.	Q.ty	Code	Parts Table	Pos.	Q.ty
31421083	C.01.02.A0011_03	14	1	31423084	C01_0_22466	31423084	1	31423105	L01_1_27708	31423105	0
	C01_1_34043	31421083	1		C01_1_34043	31423084	1		L01_2_60486	31423105	1
	C01_2_67668	31421083	1		D01_0_22506	31423084	1		L01_3_90714	31423105	1
	E.01.02.A0011_03	22	1		D01_1_27654	31423084	1	31423130	E01_2_67697	31423130	1
	E01_0_22534	31421083	1		D01_2_33546	31423084	1		J01_1_67885	31423130	1
	E01_1_23274	31421083	0		D01_3_59819	31423084	1		L01_0_23182	31423130	1
	E01_2_67697	31421083	1		D01_4_72864	31423084	1		L01_1_27708	31423130	0
	H01_0_22844	31421083	1		E01_0_22534	31423084	1		L01_2_60486	31423130	1
	J01_0_23105	31421083	1		E01_1_23274	31423084	0		L01_3_90714	31423130	1
	J01_1_67885	31421083	1		E01_2_67697	31423084	1	31424084	G01_1_34130	31424084	1
31421100	H01_0_22844	31421100	1		H01_0_22844	31423084	1	34110028	J.01.02.A0011_02	8	1
	H01_1_59887	31421100	1		H01_1_59887	31423084	1		J01_0_23105	34110028	1
31421100Z	H.01.02.A0011_03	16	1		H01_2_67804	31423084	1		J01_1_67885	34110028	1
	H01_2_67804	31421100	1		I01_0_22914	31423084	1	34211028	H.01.02.A0011_03	33	1
31421101	F.02.02.A0011_03	25			I01_1_32971	31423084	1		H01_2_67804	34211028	1
	F02_0_22647	31421101	1		I01_2_67839	31423084	1	34211041	H.01.02.A0011_03	38	1
	F02_1_59847	31421101	1		J.01.02.A0011_02	25	1		H01_2_67804	34211041	1
	F02_2_67738	31421101	1		J01_0_23105	31423084	1	34211042	F.02.02.A0011_03	17	
	L01_0_23182	31421101	1		J01_1_67885	31423084	1		F02_0_22647	34211042	1
	L01_1_27708	31421101	0		L01_0_23182	31423084	1		F02_1_59847	34211042	1
	L01_2_60486	31421101	1		L01_1_27708	31423084	0		F02_2_67738	34211042	1
	L01_3_90714	31421101	1		L01_2_60486	31423084	1	34213020	I01_0_22914	34213020	1
31421130	E.01.02.A0011_03	9	1		L01_3_90714	31423084	1		I01_1_32971	34213020	1
	E.01.02.A0011_04	9		31423105	D01_0_22506	31423105	1		I01_2_67839	34213020	1
	G01_0_22724	31421130	1		D01_1_27654	31423105	1		J.01.02.A0011_02	29	1
	G01_1_34130	31421130	1		D01_2_33546	31423105	1		J01_0_23105	34213020	1
	H.01.02.A0011_03	44	1		D01_3_59819	31423105	1		J01_1_67885	34213020	1
	H01_2_67804	31421130	1		D01_4_72864	31423105	1	34213022	J01_1_67885	34213022	1
31421132	E01_0_22534	31421132	1		G01_0_22724	31423105	1	34213024	J.01.02.A0011_02	36	1
	E01_1_23274	31421132	0		G01_1_34130	31423105	1		J01_0_23105	34213024	1
31422064	E01_0_22534	31422064	1		H.01.02.A0011_03	43	1		J01_1_67885	34213024	1
	E01_1_23274	31422064	0		H01_2_67804	31423105	1	34213060	F.02.02.A0011_03	19	
	E01_2_67697	31422064	1		I01_2_67839	31423105	1		F02_0_22647	34213060	1
31423043	I01_2_67839	31423043	1		L01_0_23182	31423105	1		F02_1_59847	34213060	1



SPARE PARTS INSTANCE INDEX

Code	Parts Table	Pos.	Q.ty	Code	Parts Table	Pos.	Q.ty	Code	Parts Table	Pos.	Q.ty
34213060	F02_2_67738	34213060	1	37111150	F02_1_59847	37111150	1	37911532	J01_0_23105	37911532	1
34213061	F.02.02.A0011_03	21			F02_2_67738	37111150	1		J01_1_67885	37911532	1
	F02_0_22647	34213061	1	37111152	F.02.02.A0011_03	34		38111191	J.01.02.A0011_02	31	1
	F02_1_59847	34213061	1		F02_0_22647	37111152	1		J01_0_23105	38111191	1
	F02_2_67738	34213061	1		F02_1_59847	37111152	1		J01_1_67885	38111191	1
	J01_0_23105	34213061	1		F02_2_67738	37111152	1	38111400	J01_1_67885	38111400	1
	J01_1_67885	34213061	1	37111250	F02_0_22647	37111250	1	38211400	J.01.02.A0011_02	21	1
34221070	H.01.02.A0011_03	39	1		F02_1_59847	37111250	1		J01_0_23105	38211400	1
	H01_2_67804	34221070	1		F02_2_67738	37111250	1		J01_1_67885	38211400	1
34311060	G01_0_22724	34311060	1		G01_0_22724	37111250	1	38211500	F.02.02.A0011_03	23	
	G01_1_34130	34311060	1		G01_1_34130	37111250	1		F02_0_22647	38211500	1
35111052	F.02.02.A0011_03	30		37111255	F.02.02.A0011_03	28			F02_1_59847	38211500	1
	F02_0_22647	35111052	1	37112173	D01_0_22506	37112173	1		F02_2_67738	38211500	1
	F02_1_59847	35111052	1		D01_1_27654	37112173	1	38212501	G01_0_22724	38212501	1
	F02_2_67738	35111052	1		D01_2_33546	37112173	1		G01_1_34130	38212501	1
	G01_0_22724	35111052	1		D01_3_59819	37112173	1	38213800	F.02.02.A0011_03	9	
	G01_1_34130	35111052	1		D01_4_72864	37112173	1		F02_0_22647	38213800	1
35111055	F.02.02.A0011_03	8		37112229	F.02.02.A0011_03	7			F02_1_59847	38213800	1
	F02_0_22647	35111055	1		F02_0_22647	37112229	1		F02_2_67738	38213800	1
	F02_1_59847	35111055	1		F02_1_59847	37112229	1	39111608	L01_2_60486	39111608	1
	F02_2_67738	35111055	1		F02_2_67738	37112229	1		L01_3_90714	39111608	1
35121014	E.01.02.A0011_03	29	1	37112231	D01_0_22506	37112231	1	39111665	L01_3_90714	39111665	1
	E01_1_23274	35121014	1		D01_1_27654	37112231	1	39113501	L01_0_23182	39113501	1
	E01_2_67697	35121014	1	37112233	D01_0_22506	37112233	1		L01_1_27708	39113501	0
35121031	F.02.02.A0011_03	6			D01_1_27654	37112233	1		L01_2_60486	39113501	1
	F02_0_22647	35121031	1	37320120	F.02.02.A0011_03	14			L01_3_90714	39113501	1
	F02_1_59847	35121031	1		F02_0_22647	37320120	1	39113502	L01_0_23182	39113502	1
	F02_2_67738	35121031	1		F02_1_59847	37320120	1		L01_1_27708	39113502	0
35211120	F.02.02.A0011_03	35			F02_2_67738	37320120	1		L01_2_60486	39113502	1
	F02_0_22647	35211120	1	37910832	F.02.02.A0011_03	12			L01_3_90714	39113502	1
	F02_1_59847	35211120	1		F02_0_22647	37910832	1	39114008	L01_0_23182	39114008	1
	F02_2_67738	35211120	1		F02_1_59847	37910832	1		L01_1_27708	39114008	0
37111150	F.02.02.A0011_03	1			F02_2_67738	37910832	1		L01_2_60486	39114008	1
	F02_0_22647	37111150	1	37911532	J.01.02.A0011_02	7	1		L01_3_90714	39114008	1



SPARE PARTS INSTANCE INDEX

Code	Parts Table	Pos.	Q.ty	Code	Parts Table	Pos.	Q.ty	Code	Parts Table	Pos.	Q.ty
39114010	L01_0_23182	39114010	1	39415010	L01_1_27708	39415010	0	52456339	F02_0_22647	52456339	1
	L01_1_27708	39114010	0		L01_2_60486	39415010	1		F02_1_59847	52456339	1
	L01_2_60486	39114010	1		L01_3_90714	39415010	1		F02_2_67738	52456339	1
	L01_3_90714	39114010	1	39416018	L01_0_23182	39416018	1	52456349	F.02.02.A0011_03	26	
39115010	L01_0_23182	39115010	1		L01_1_27708	39416018	0		F02_0_22647	52456349	1
	L01_1_27708	39115010	0		L01_2_60486	39416018	1		F02_1_59847	52456349	1
	L01_2_60486	39115010	1		L01_3_90714	39416018	1		F02_2_67738	52456349	1
	L01_3_90714	39115010	1	39416025	L01_0_23182	39416025	1	52456354	F.02.02.A0011_03	31	
39116018	L01_0_23182	39116018	1		L01_1_27708	39416025	0	52456355	F02_0_22647	52456355	1
	L01_1_27708	39116018	0		L01_2_60486	39416025	1	52456361	F.02.02.A0011_03	32	
	L01_2_60486	39116018	1		L01_3_90714	39416025	1	52456362	F02_0_22647	52456362	1
	L01_3_90714	39116018	1	50956262	D01_0_22506	50956262	1		F02_1_59847	52456362	1
39118020	L01_0_23182	39118020	1		D01_1_27654	50956262	1		F02_2_67738	52456362	1
	L01_1_27708	39118020	0		D01_2_33546	50956262	1	52456370	F.02.02.A0011_03	3	
	L01_2_60486	39118020	1		D01_3_59819	50956262	1		F02_0_22647	52456370	1
	L01_3_90714	39118020	1		D01_4_72864	50956262	1		F02_1_59847	52456370	1
39118021	L01_0_23182	39118021	1	52156810Z	J.03.02.A0011_00	21	1		F02_2_67738	52456370	1
	L01_1_27708	39118021	0	52156917	H.01.02.A0011_03	17	1	52456389	F.02.02.A0011_03	20	
	L01_2_60486	39118021	1		H01_0_22844	52156917	1		F02_0_22647	52456389	1
	L01_3_90714	39118021	1		H01_1_59887	52156917	1		F02_1_59847	52456389	1
39411608	L01_2_60486	39411608	1		H01_2_67804	52156917	1		F02_2_67738	52456389	1
	L01_3_90714	39411608	1	52357250	J.01.02.A0011_02	30	1	52456390	F.02.02.A0011_03	22	
39413502	L01_0_23182	39413502	1		J01_0_23105	52357250	1		F02_0_22647	52456390	1
	L01_1_27708	39413502	0		J01_1_67885	52357250	1		F02_1_59847	52456390	1
	L01_2_60486	39413502	1	52447896	D01_0_22506	52447896	1		F02_2_67738	52456390	1
	L01_3_90714	39413502	1		D01_1_27654	52447896	1	52456392	F02_1_59847	52456392	1
39414008	L01_0_23182	39414008	1		D01_2_33546	52447896	1		F02_2_67738	52456392	1
	L01_1_27708	39414008	0		D01_3_59819	52447896	1	52456706	F.02.02.A0011_03	5	
	L01_2_60486	39414008	1		D01_4_72864	52447896	1	53052175	M01_3_91676	53052175	1
	L01_3_90714	39414008	1	52456335	F.02.02.A0011_03	10		53052176	M01_3_91676	53052176	1
39414010	L01_0_23182	39414010	1		F02_0_22647	52456335	1	53143128V	E.01.02.A0011_03	20	1
	L01_1_27708	39414010	0		F02_1_59847	52456335	1		E.01.02.A0011_04	19	
	L01_2_60486	39414010	1		F02_2_67738	52456335	1		E01_2_67697	53143128	1
39415010	L01_0_23182	39415010	1	52456339	F.02.02.A0011_03	33		53143712	L01_0_23182	53143712	1



SPARE PARTS INSTANCE INDEX

Code	Parts Table	Pos.	Q.ty
53143712	L01_1_27708	53143712	0
	L01_2_60486	53143712	1
	L01_3_90714	53143712	1
53143875V	E.01.02.A0011_03	20	1
	E.01.02.A0011_04	19	
	E01_2_67697	53143875	1
53152401	E01_0_22534	53152401	1
	E01_1_23274	53152401	0
53152408	E01_0_22534	53152408	1
	E01_1_23274	53152408	0
53152409	E01_0_22534	53152409	1
	E01_1_23274	53152409	0
53152410	E01_0_22534	53152410	1
	E01_1_23274	53152410	0
53156150	D01_0_22506	53156150	1
	D01_1_27654	53156150	1
	D01_2_33546	53156150	1
	D01_3_59819	53156150	1
	D01_4_72864	53156150	1
53156325V	E.01.02.A0011_03	17	1
	E.01.02.A0011_04	16	
	E01_2_67697	53156325	1
53156332B	E01_2_67697	53156332	1
53156332V	E.01.02.A0011_03	6	1
	E.01.02.A0011_04	6	
53156342V	E.01.02.A0011_03	1	1
	E.01.02.A0011_04	1	
	E01_2_67697	53156342	1
53156346V	E.01.02.A0011_03	17	1
	E.01.02.A0011_04	16	
	E01_2_67697	53156346	1
53156860	J.03.02.A0011_00	6	1
53247488	D01_0_22506	53247488	1
	D01_1_27654	53247488	1

Code	Parts Table	Pos.	Q.ty
53247488	D01_2_33546	53247488	1
	D01_3_59819	53247488	1
	D01_4_72864	53247488	1
54143090	G01_0_22724	54143090	1
	G01_1_34130	54143090	1
54143149	G01_0_22724	54143149	1
	G01_1_34130	54143149	1
55102678	E.01.02.A0011_03	12	1
	E.01.02.A0011_04	14	
	E01_0_22534	55102678	1
	E01_1_23274	55102678	0
	E01_2_67697	55102678	1
55102714	H01_0_22844	55102714	1
	H01_1_59887	55102714	1
	H01_2_67804	55102714	1
55142076	J01_0_23105	55142076	1
	J01_1_67885	55142076	1
55147842	D01_0_22506	55147842	1
	D01_1_27654	55147842	1
	D01_2_33546	55147842	1
	D01_3_59819	55147842	1
	D01_4_72864	55147842	1
55157212	H.01.02.A0011_03	10	1
	J.01.02.A0011_02	12	1
	J.03.02.A0011_00	7	1
55157213	H.01.02.A0011_03	5	1
	J.01.02.A0011_02	5	1
	J.03.02.A0011_00	11	1
55157214	J.03.02.A0011_00	22	1
55157215	J.03.02.A0011_00	23	1
55157609	D01_0_22506	55157609	1
	D01_1_27654	55157609	1
	D01_2_33546	55157609	1
	D01_3_59819	55157609	1

Code	Parts Table	Pos.	Q.ty
55157609	D01_4_72864	55157609	1
55220363	E.01.02.A0011_03	26	1
	E01_1_23274	55220363	1
	E01_2_67697	55220363	1
55242528	J.01.02.A0011_02	4	1
	J01_0_23105	55242528	1
	J01_1_67885	55242528	1
55243340	H.01.02.A0011_03	8	1
	H01_0_22844	55243340	1
	H01_1_59887	55243340	1
	H01_2_67804	55243340	1
	I01_2_67839	55243340	1
55243592	G01_1_34130	55243592	1
55248038	I.01.02.A0011_03	10	1
	I01_0_22914	55248038	1
	I01_1_32971	55248038	1
	I01_2_67839	55248038	1
55248041	I.01.02.A0011_03	15	1
	I01_0_22914	55248041	1
	I01_1_32971	55248041	1
	I01_2_67839	55248041	1
55248283	I01_0_22914	55248283	1
	I01_1_32971	55248283	1
	I01_2_67839	55248283	1
55248284	I01_0_22914	55248284	1
	I01_1_32971	55248284	1
	I01_2_67839	55248284	1
55248379	J.01.02.A0011_02	37	1
	J01_0_23105	55248379	1
	J01_1_67885	55248379	1
55249668	H01_0_22844	55249668	1
	H01_1_59887	55249668	1
	H01_2_67804	55249668	1
55251686	H.01.02.A0011_03	36	1



SPARE PARTS INSTANCE INDEX

Code	Parts Table	Pos.	Q.ty	Code	Parts Table	Pos.	Q.ty	Code	Parts Table	Pos.	Q.ty
55251686	H01_2_67804	55251686	1	56147845	D01_1_27654	56147845	1	56156276	D01_1_27654	56156276	1
55251688	H.01.02.A0011_03	37	1		D01_2_33546	56147845	1		D01_2_33546	56156276	1
	H01_2_67804	55251688	1		D01_3_59819	56147845	1		D01_3_59819	56156276	1
55252405	C.01.02.A0011_03	2	1		D01_4_72864	56147845	1		D01_4_72864	56156276	1
	C.01.02.A0011_04	12		56147923N	E.01.02.A0011_04	20		56156281	D01_1_27654	56156281	1
	C01_0_22466	55252405	1	56148037	I.01.02.A0011_03	8	1		D01_2_33546	56156281	1
	C01_1_34043	55252405	1		I01_0_22914	56148037	1		D01_3_59819	56156281	1
	C01_2_67668	55252405	1		I01_1_32971	56148037	1		D01_4_72864	56156281	1
55252406	C.01.02.A0011_03	1	1		I01_2_67839	56148037	1	56156284	D01_2_33546	56156284	1
	C.01.02.A0011_04	11		56148285	I01_0_22914	56148285	1		D01_3_59819	56156284	1
	C01_0_22466	55252406	1		I01_1_32971	56148285	1		D01_4_72864	56156284	1
	C01_1_34043	55252406	1		I01_2_67839	56148285	1	56156285	D01_2_33546	56156285	1
	C01_2_67668	55252406	1	56148286	I01_0_22914	56148286	1		D01_3_59819	56156285	1
55256835	J.03.02.A0011_00	16	1		I01_1_32971	56148286	1		D01_4_72864	56156285	1
55256836	J.03.02.A0011_00	15	1		I01_2_67839	56148286	1	56156487	G01_1_34130	56156487	1
55257313	J.01.02.A0011_02	28	1	56148287	I01_0_22914	56148287	1	56156488	G01_1_34130	56156488	1
	J01_0_23105	55257313	1		I01_1_32971	56148287	1	56156603Z	I.01.02.A0011_03	2	1
	J01_1_67885	55257313	1		J.03.02.A0011_00	5	1	56156792N	J.01.02.A0011_02	11	1
55257321	J.01.02.A0011_02	34	1	56148470N	I.01.02.A0011_03	13	1	56156832Z	J.03.02.A0011_00	4	1
	J01_0_23105	55257321	1	56150361	I01_0_22914	56150361	1	56156859Z	J.03.02.A0011_00	19	1
	J01_1_67885	55257321	1		I01_1_32971	56150361	1	56156874N	I.01.02.A0011_03	19	1
552C1001	C.01.02.A0011_04	3			I01_2_67839	56150361	1	56156940	H.01.02.A0011_03	20	1
56142314	G01_1_34130	56142314	1	56152241	C01_1_34043	56152241	1		H01_0_22844	56156940	1
56143059	G01_0_22724	56143059	1	56152403	E01_0_22534	56152403	1		H01_1_59887	56156940	1
	G01_1_34130	56143059	1		E01_1_23274	56152403	0		H01_2_67804	56156940	1
56147520Z	E.01.02.A0011_03	4	1	56156119	C01_0_22466	56156119	1	56156948	H01_0_22844	56156948	1
	E.01.02.A0011_04	4			C01_1_34043	56156119	1		H01_1_59887	56156948	1
	E01_2_67697	56147520	1	56156119N	C.01.02.A0011_03	13	1	56156948N	H.01.02.A0011_03	12	1
56147655	I01_0_22914	56147655	1		C.01.02.A0011_04	5			H01_2_67804	56156948	1
	I01_1_32971	56147655	1		C01_2_67668	56156119	1	56156990V	C.01.02.A0011_03	16	1
56147655N	I.01.02.A0011_03	4	1	56156195H	J.01.02.A0011_02	14	1		C01_2_67668	56156990	1
	I01_2_67839	56147655	1	56156261	E.01.02.A0011_03	27	1	56157234	J01_1_67885	56157234	1
56147711	I01_2_67839	56147711	1		E01_1_23274	56156261	1	56157248	J01_1_67885	56157248	1
56147845	D01_0_22506	56147845	1		E01_2_67697	56156261	1	56157257	J01_0_23105	56157257	1



SPARE PARTS INSTANCE INDEX

Code	Parts Table	Pos.	Q.ty	Code	Parts Table	Pos.	Q.ty	Code	Parts Table	Pos.	Q.ty
56157257	J01_1_67885	56157257	1	56157411Z	H.01.02.A0011_03	27	1	56356348	F02_0_22647	56356348	1
56157257Z	J.01.02.A0011_02	20	1		H01_2_67804	56157411	1		F02_1_59847	56356348	1
56157271	J01_0_23105	56157271	1	56157412	H.01.02.A0011_03	30	1		F02_2_67738	56356348	1
	J01_1_67885	56157271	1		H01_0_22844	56157412	1	56356833Z	J.03.02.A0011_00	8	1
56157271N	J.01.02.A0011_02	3	1		H01_1_59887	56157412	1	56356840Z	J.03.02.A0011_00	2	1
56157274	J.01.02.A0011_02	24	1		H01_2_67804	56157412	1	56356924	H.01.02.A0011_03	2	1
	J01_0_23105	56157274	1	561C1002N	C.01.02.A0011_04	1			H01_0_22844	56356924	1
	J01_1_67885	56157274	1	56343058	G01_0_22724	56343058	1		H01_1_59887	56356924	1
56157282	J01_1_67885	56157282	1		G01_1_34130	56343058	1		H01_2_67804	56356924	1
56157283	J01_0_23105	56157283	1	56347484	D01_0_22506	56347484	1	56359553	L01_0_23182	56359553	1
	J01_1_67885	56157283	1		D01_1_27654	56347484	1		L01_1_27708	56359553	0
56157312	J01_0_23105	56157312	1	56349782	D01_0_22506	56349782	1		L01_2_60486	56359553	1
	J01_1_67885	56157312	1	56351685	H01_2_67804	56351685	1		L01_3_90714	56359553	1
56157323	J01_1_67885	56157323	1	56351685Z	H.01.02.A0011_03	34	1	56359554	L01_0_23182	56359554	1
56157324	J01_0_23105	56157324	1	56356165	D01_0_22506	56356165	1		L01_1_27708	56359554	0
	J01_1_67885	56157324	1	56356251	D01_0_22506	56356251	1		L01_2_60486	56359554	1
56157324N	J.01.02.A0011_02	35	1		D01_1_27654	56356251	1		L01_3_90714	56359554	1
56157332	I01_0_22914	56157332	1	56356328	F.02.02.A0011_03	29		56359593	L01_0_23182	56359593	1
	I01_1_32971	56157332	1		F02_0_22647	56356328	1		L01_1_27708	56359593	0
	I01_2_67839	56157332	1		F02_1_59847	56356328	1		L01_2_60486	56359593	1
56157349	J01_0_23105	56157349	1		F02_2_67738	56356328	1		L01_3_90714	56359593	1
	J01_1_67885	56157349	1	56356329	F.02.02.A0011_03	29		56456347	F.02.02.A0011_03	15	
56157356	J01_0_23105	56157356	1		F02_0_22647	56356329	1		F02_0_22647	56456347	1
	J01_1_67885	56157356	1		F02_1_59847	56356329	1		F02_1_59847	56456347	1
56157393N	C.01.02.A0011_03	10	1		F02_2_67738	56356329	1		F02_2_67738	56456347	1
	C01_2_67668	56157393	1	56356330	F.02.02.A0011_03	29		56456351	F02_0_22647	56456351	1
56157394	E01_0_22534	56157394	1		F02_0_22647	56356330	1		F02_1_59847	56456351	1
	E01_1_23274	56157394	0		F02_1_59847	56356330	1		F02_2_67738	56456351	1
56157394N	E.01.02.A0011_03	24	1		F02_2_67738	56356330	1	56456475	F.02.02.A0011_03	27	
	E01_2_67697	56157394	1	56356331	F.02.02.A0011_03	29			F02_0_22647	56456475	1
56157399N	C.01.02.A0011_03	11	1		F02_0_22647	56356331	1		F02_1_59847	56456475	1
	C01_2_67668	56157399	1		F02_1_59847	56356331	1		F02_2_67738	56456475	1
56157411	H01_0_22844	56157411	1		F02_2_67738	56356331	1	56456736	F.02.02.A0011_03	13	
	H01_1_59887	56157411	1	56356348	F.02.02.A0011_03	16		58002429	I01_0_22914	58002429	1



SPARE PARTS INSTANCE INDEX

Code	Parts Table	Pos.	Q.ty	Code	Parts Table	Pos.	Q.ty	Code	Parts Table	Pos.	Q.ty
58002429	I01_1_32971	58002429	1	58043117	E01_1_23274	58043117	0	58048035	C01_2_67668	58048035	1
	I01_2_67839	58002429	1		E01_2_67697	58043117	1	58048330	L01_3_90714	58048330	1
58002538	I.01.02.A0011_03	18	1	58043176	J.01.02.A0011_02	19	1	58048355	I.01.02.A0011_03	7	1
	I01_0_22914	58002538	1		J01_0_23105	58043176	1	58049830	J.03.02.A0011_00	20	1
	I01_1_32971	58002538	1		J01_1_67885	58043176	1	58050345	I.01.02.A0011_03	3	1
58020258	J01_1_67885	58020258	1	58043219	I01_0_22914	58043219	1	58051670	I01_0_22914	58051670	1
58042167	H.01.02.A0011_03	21	1		I01_1_32971	58043219	1		I01_1_32971	58051670	1
	H01_0_22844	58042167	1	58043250	L01_3_90714	58043250	1		I01_2_67839	58051670	1
	H01_1_59887	58042167	1	58043370	L01_3_90714	58043370	1	58052019	M01_2_67927	58052019	1
	H01_2_67804	58042167	1	58044804	L01_3_90714	58044804	1	58052029	M01_0_23235	58052029	1
	I01_0_22914	58042167	1	58046912	M02_0_23244	58046912	1		M01_1_34253	58052029	1
	I01_1_32971	58042167	1		M02_1_34264	58046912	1		M01_2_67927	58052029	1
	I01_2_67839	58042167	1		M02_2_67938	58046912	1	58052157	M01_0_23235	58052157	1
58042200	I01_0_22914	58042200	1	58046932	M02_3_91699	58046932	1		M01_1_34253	58052157	1
	I01_1_32971	58042200	1	58047712	H.01.02.A0011_03	26	1		M01_2_67927	58052157	1
	I01_2_67839	58042200	1		H01_0_22844	58047712	1	58052158	M01_0_23235	58052158	1
	J.03.02.A0011_00	24	1		H01_1_59887	58047712	1		M01_1_34253	58052158	1
58042202	I01_0_22914	58042202	1		H01_2_67804	58047712	1		M01_2_67927	58052158	1
	I01_1_32971	58042202	1		I01_2_67839	58047712	1	58052159	M01_0_23235	58052159	1
	I01_2_67839	58042202	1	58048000	I.01.02.A0011_03	6	1		M01_1_34253	58052159	1
58042219	H.01.02.A0011_03	35	1		I01_0_22914	58048000	1		M01_2_67927	58052159	1
	H01_2_67804	58042219	1		I01_1_32971	58048000	1	58052160	M01_0_23235	58052160	1
58043053	E.01.02.A0011_03	14	1		I01_2_67839	58048000	1		M01_1_34253	58052160	1
	E.01.02.A0011_04	13		58048002	I01_0_22914	58048002	1		M01_2_67927	58052160	1
	E01_0_22534	58043053	1		I01_1_32971	58048002	1	58052162	M01_0_23235	58052162	1
	E01_1_23274	58043053	0	58048009	H.01.02.A0011_03	25	1		M01_1_34253	58052162	1
	E01_2_67697	58043053	1		H01_0_22844	58048009	1		M01_2_67927	58052162	1
58043086	F.02.02.A0011_03	18			H01_1_59887	58048009	1	58052163	M01_0_23235	58052163	1
	F02_0_22647	58043086	1		H01_2_67804	58048009	1		M01_1_34253	58052163	1
	F02_1_59847	58043086	1		I01_2_67839	58048009	1		M01_2_67927	58052163	1
	F02_2_67738	58043086	1	58048012	I01_0_22914	58048012	1	58052164	M01_0_23235	58052164	1
58043117	E.01.02.A0011_03	18	1		I01_1_32971	58048012	1		M01_1_34253	58052164	1
	E.01.02.A0011_04	17			I01_2_67839	58048012	1		M01_2_67927	58052164	1
	E01_0_22534	58043117	1	58048035	C.01.02.A0011_03	9	1	58052165	M01_1_34253	58052165	1



SPARE PARTS INSTANCE INDEX

Code	Parts Table	Pos.	Q.ty	Code	Parts Table	Pos.	Q.ty	Code	Parts Table	Pos.	Q.ty
58052165	M01_2_67927	58052165	1	58056154	I01_0_22914	58056154	1	58056918Z	H.01.02.A0011_03	3	1
	M01_3_91676	58052165	1		I01_1_32971	58056154	1		H01_2_67804	58056918	1
58052167	M01_2_67927	58052167	1		I01_2_67839	58056154	1	58056942	H01_0_22844	58056942	1
58052183	M01_3_91676	58052183	1	58056155	I.01.02.A0011_03	20	1		H01_1_59887	58056942	1
58052184	M01_3_91676	58052184	1		I01_0_22914	58056155	1	58056942N	H.01.02.A0011_03	13	1
58052185	M01_3_91676	58052185	1		I01_1_32971	58056155	1		H01_2_67804	58056942	1
58052186	M01_3_91676	58052186	1		I01_2_67839	58056155	1	58056991	C.01.02.A0011_03	12	1
58052187	M01_3_91676	58052187	1	58056158	I01_0_22914	58056158	1		C.01.02.A0011_04	4	
58052188	M01_3_91676	58052188	1		I01_1_32971	58056158	1		C01_2_67668	58056991	1
58052189	M01_3_91676	58052189	1		I01_2_67839	58056158	1		H.01.02.A0011_03	19	1
58052190	M01_3_91676	58052190	1	58056164	I01_0_22914	58056164	1		H01_0_22844	58056991	1
58052274	L01_0_23182	58052274	1		I01_1_32971	58056164	1		H01_1_59887	58056991	1
	L01_1_27708	58052274	0		I01_2_67839	58056164	1		H01_2_67804	58056991	1
	L01_2_60486	58052274	1	58056193	I.01.02.A0011_03	22	1	58057232	J01_0_23105	58057232	1
58052280	L01_1_27708	58052280	1	58056391	F.02.02.A0011_03	11			J01_1_67885	58057232	1
	L01_2_60486	58052280	1		F02_0_22647	58056391	1	58057232Z	J.01.02.A0011_02	2	1
58052281	L01_0_23182	58052281	1		F02_1_59847	58056391	1	58057263	I01_2_67839	58057263	1
	L01_1_27708	58052281	0		F02_2_67738	58056391	1	58057266	H01_2_67804	58057266	1
	L01_2_60486	58052281	1	58056593	I.01.02.A0011_03	12	1	58057273	J.01.02.A0011_02	27	1
58052289	L01_2_60486	58052289	1		I01_0_22914	58056593	1		J01_0_23105	58057273	1
58052297	L01_2_60486	58052297	1		I01_1_32971	58056593	1		J01_1_67885	58057273	1
58052325	L01_0_23182	58052325	1	58056593Z	I01_2_67839	58056593	1	58057284	I01_0_22914	58057284	1
	L01_1_27708	58052325	0	58056595	I.01.02.A0011_03	17	1		I01_1_32971	58057284	1
	L01_2_60486	58052325	1		I01_0_22914	58056595	1		I01_2_67839	58057284	1
58052326	L01_0_23182	58052326	1		I01_1_32971	58056595	1	58057297	I01_2_67839	58057297	1
	L01_1_27708	58052326	0		I01_2_67839	58056595	1	58057329	I01_0_22914	58057329	1
	L01_2_60486	58052326	1		J.03.02.A0011_00	17	1		I01_1_32971	58057329	1
58052327	L01_0_23182	58052327	1	58056815	I.01.02.A0011_03	21	1		I01_2_67839	58057329	1
	L01_1_27708	58052327	0	58056848	J.03.02.A0011_00	3	1	58057385	C.01.02.A0011_03	8	1
	L01_2_60486	58052327	1	58056864	M02_3_91699	58056864	1		C.01.02.A0011_04	13	
58053035	I01_0_22914	58053035	1	58056867	M02_3_91699	58056867	1		C01_0_22466	58057385	1
	I01_1_32971	58053035	1	58056868	M02_3_91699	58056868	1		C01_1_34043	58057385	1
	I01_2_67839	58053035	1	58056918	H01_0_22844	58056918	1		C01_2_67668	58057385	1
58056154	I.01.02.A0011_03	20	1		H01_1_59887	58056918	1	58057401	I01_2_67839	58057401	1



SPARE PARTS INSTANCE INDEX

Code	Parts Table	Pos.	Q.ty	Code	Parts Table	Pos.	Q.ty	Code	Parts Table	Pos.	Q.ty
58057413	H.01.02.A0011_03	28	1	58057712	M02_0_23244	58057712	1	58057768	M02_3_91699	58057768	1
	H01_0_22844	58057413	1		M02_1_34264	58057712	1	58057770	M02_0_23244	58057770	1
	H01_1_59887	58057413	1		M02_2_67938	58057712	1		M02_1_34264	58057770	1
	H01_2_67804	58057413	1	58057722	M02_0_23244	58057722	1		M02_2_67938	58057770	1
58057416	H01_0_22844	58057416	1		M02_1_34264	58057722	1		M02_3_91699	58057770	1
	I01_0_22914	58057416	1		M02_2_67938	58057722	1	58057771	M02_0_23244	58057771	1
	I01_1_32971	58057416	1		M02_3_91699	58057722	1		M02_1_34264	58057771	1
	I01_2_67839	58057416	1	58057724	M02_0_23244	58057724	1		M02_2_67938	58057771	1
58057417	H.01.02.A0011_03	23	1		M02_1_34264	58057724	1		M02_3_91699	58057771	1
	H01_0_22844	58057417	1		M02_2_67938	58057724	1	58057772	M02_0_23244	58057772	1
	H01_1_59887	58057417	1		M02_3_91699	58057724	1		M02_1_34264	58057772	1
	H01_2_67804	58057417	1	58057732	M02_0_23244	58057732	1		M02_2_67938	58057772	1
58057418	I.01.02.A0011_03	7	1		M02_1_34264	58057732	1		M02_3_91699	58057772	1
58057419	H01_1_59887	58057419	1		M02_2_67938	58057732	1	58057773	M02_0_23244	58057773	1
	H01_2_67804	58057419	1		M02_3_91699	58057732	1		M02_1_34264	58057773	1
58057458	M02_3_91699	58057458	1	58057746	M02_0_23244	58057746	1		M02_2_67938	58057773	1
58057625	M02_0_23244	58057625	1		M02_1_34264	58057746	1		M02_3_91699	58057773	1
	M02_1_34264	58057625	1		M02_2_67938	58057746	1	58057774	M02_0_23244	58057774	1
	M02_2_67938	58057625	1		M02_3_91699	58057746	1		M02_1_34264	58057774	1
	M02_3_91699	58057625	1	58057747	M02_0_23244	58057747	1		M02_2_67938	58057774	1
58057676	M02_0_23244	58057676	1		M02_1_34264	58057747	1		M02_3_91699	58057774	1
	M02_1_34264	58057676	1		M02_2_67938	58057747	1	58057795	L01_3_90714	58057795	1
	M02_2_67938	58057676	1		M02_3_91699	58057747	1	58057797	L01_3_90714	58057797	1
	M02_3_91699	58057676	1	58057748	M02_0_23244	58057748	1	58057799	L01_3_90714	58057799	1
58057678	M02_1_34264	58057678	1		M02_1_34264	58057748	1	58057839	L01_3_90714	58057839	1
	M02_2_67938	58057678	1		M02_2_67938	58057748	1	58093089	M02_0_23244	58093089	1
	M02_3_91699	58057678	1		M02_3_91699	58057748	1		M02_1_34264	58093089	1
58057688	M02_2_67938	58057688	1	58057767	M02_0_23244	58057767	1		M02_2_67938	58093089	1
58057698	M02_0_23244	58057698	1		M02_1_34264	58057767	1		M02_3_91699	58093089	1
	M02_1_34264	58057698	1		M02_2_67938	58057767	1	58147704	I01_0_22914	58147704	1
	M02_2_67938	58057698	1		M02_3_91699	58057767	1		I01_1_32971	58147704	1
58057706	M02_0_23244	58057706	1	58057768	M02_0_23244	58057768	1		I01_2_67839	58147704	1
	M02_1_34264	58057706	1		M02_1_34264	58057768	1	58150313	I.01.02.A0011_03	9	1
	M02_2_67938	58057706	1		M02_2_67938	58057768	1		I01_0_22914	58150313	1



SPARE PARTS INSTANCE INDEX

Code	Parts Table	Pos.	Q.ty	Code	Parts Table	Pos.	Q.ty	Code	Parts Table	Pos.	Q.ty
58150313	I01_1_32971	58150313	1	59056089	C01_0_22466	59056089	1	59056952N	H.01.02.A0011_03	1	1
	I01_2_67839	58150313	1		C01_1_34043	59056089	1		H01_2_67804	59056952	1
58156156	I01_0_22914	58156156	1	59056089N	C.01.02.A0011_03	13	1	59056995	H01_0_22844	59056995	1
	I01_1_32971	58156156	1		C.01.02.A0011_04	5		59057010N	H.01.02.A0011_03	9	1
	I01_2_67839	58156156	1		C01_2_67668	59056089	1	59057112	I01_2_67839	59057112	1
581C1004	C.01.02.A0011_04	2		59056111	C01_2_67668	59056111	1	59057116	I01_0_22914	59057116	1
59015425	E.01.02.A0011_03	11	1	59056111N	C.01.02.A0011_03	13	1	59057228	J01_1_67885	59057228	1
	E.01.02.A0011_04	15			C.01.02.A0011_04	5		59057251	J01_0_23105	59057251	1
	E01_0_22534	59015425	1	59056258	E.01.02.A0011_03	21	1		J01_1_67885	59057251	1
	E01_1_23274	59015425	0		E01_0_22534	59056258	1	59057251N	J.01.02.A0011_02	18	1
	E01_2_67697	59015425	1		E01_1_23274	59056258	0	59057319	J.01.02.A0011_02	26	1
59043063	G01_0_22724	59043063	1		E01_2_67697	59056258	1		J01_0_23105	59057319	1
	G01_1_34130	59043063	1	59056259	E01_1_23274	59056259	1		J01_1_67885	59057319	1
59047450	C01_0_22466	59047450	1	59056259Z	E.01.02.A0011_03	28	1	59057325	J01_0_23105	59057325	1
	C01_1_34043	59047450	1		E01_2_67697	59056259	1		J01_1_67885	59057325	1
59047463	C01_0_22466	59047463	1	59056365	F02_0_22647	59056365	1	59059551	L01_0_23182	59059551	1
	C01_1_34043	59047463	1		F02_1_59847	59056365	1		L01_1_27708	59059551	0
59047709	I01_2_67839	59047709	1		F02_2_67738	59056365	1		L01_2_60486	59059551	1
59047743	L01_0_23182	59047743	1	59056373	F02_0_22647	59056373	1		L01_3_90714	59059551	1
	L01_1_27708	59047743	0	59056384	F.02.02.A0011_03	2		59059561	L01_0_23182	59059561	1
	L01_2_60486	59047743	1	59056394	F02_1_59847	59056394	1		L01_1_27708	59059561	0
	L01_3_90714	59047743	1		F02_2_67738	59056394	1		L01_2_60486	59059561	1
59047745	L01_0_23182	59047745	1	59056707	F.02.02.A0011_03	4			L01_3_90714	59059561	1
	L01_1_27708	59047745	0	59056817V	H.01.02.A0011_03	40	1	59059571	L01_0_23182	59059571	1
	L01_2_60486	59047745	1	59056824	J01_1_67885	59056824	1		L01_1_27708	59059571	0
	L01_3_90714	59047745	1	59056905	J01_1_67885	59056905	1		L01_2_60486	59059571	1
59047927	C01_0_22466	59047927	1	59056920	J.01.02.A0011_02	16	1		L01_3_90714	59059571	1
	C01_1_34043	59047927	1		J01_0_23105	59056920	1	59059591	L01_0_23182	59059591	1
59051682	H01_2_67804	59051682	1		J01_1_67885	59056920	1		L01_1_27708	59059591	0
59056051	C.01.02.A0011_03	13	1	59056935	H01_0_22844	59056935	1		L01_2_60486	59059591	1
	C01_0_22466	59056051	1		H01_1_59887	59056935	1		L01_3_90714	59059591	1
	C01_1_34043	59056051	1	59056935N	H01_2_67804	59056935	1	59247884	D01_0_22506	59247884	1
59056051N	C.01.02.A0011_04	5		59056952	H01_0_22844	59056952	1		D01_1_27654	59247884	1
	C01_2_67668	59056051	1		H01_1_59887	59056952	1		D01_2_33546	59247884	1



SPARE PARTS INSTANCE INDEX

Code	Parts Table	Pos.	Q.ty	Code	Parts Table	Pos.	Q.ty	Code	Parts Table	Pos.	Q.ty
59247884	D01_3_59819	59247884	1	59257409	H01_1_59887	59257409	1	92459580	L01_0_23182	92459580	1
	D01_4_72864	59247884	1		H01_2_67804	59257409	1		L01_1_27708	92459580	0
59247924	D01_2_33546	59247924	1	59259555	L01_0_23182	59259555	1		L01_2_60486	92459580	1
	D01_3_59819	59247924	1		L01_1_27708	59259555	0		L01_3_90714	92459580	1
	D01_4_72864	59247924	1		L01_2_60486	59259555	1	F0831193010	J.01.02.A0011_02	33	1
59247971	D01_0_22506	59247971	1		L01_3_90714	59259555	1		J01_0_23105	F0831193	1
	D01_1_27654	59247971	1	59259563	L01_0_23182	59259563	1		J01_1_67885	F0831193	1
	D01_2_33546	59247971	1		L01_1_27708	59259563	0	F0849044070	L01_0_23182	F0849044	1
	D01_3_59819	59247971	1		L01_2_60486	59259563	1		L01_1_27708	F0849044	0
	D01_4_72864	59247971	1		L01_3_90714	59259563	1		L01_2_60486	F0849044	1
59256253	D01_0_22506	59256253	1	59259567	L01_0_23182	59259567	1				
59256255	D01_2_33546	59256255	1		L01_1_27708	59259567	0				
59256257	D01_0_22506	59256257	1		L01_2_60486	59259567	1				
59256265	D01_0_22506	59256265	1		L01_3_90714	59259567	1				
59256275	D01_1_27654	59256275	1	59259578	L01_0_23182	59259578	1				
	D01_2_33546	59256275	1		L01_1_27708	59259578	0				
	D01_3_59819	59256275	1		L01_2_60486	59259578	1				
	D01_4_72864	59256275	1		L01_3_90714	59259578	1				
59256279	D01_2_33546	59256279	1	59259580	L01_0_23182	59259580	1				
	D01_3_59819	59256279	1		L01_1_27708	59259580	0				
	D01_4_72864	59256279	1		L01_2_60486	59259580	1				
59256280	D01_1_27654	59256280	1		L01_3_90714	59259580	1				
	D01_2_33546	59256280	1	59259598	L01_0_23182	59259598	1				
	D01_3_59819	59256280	1		L01_1_27708	59259598	0				
	D01_4_72864	59256280	1		L01_2_60486	59259598	1				
59256850	J.03.02.A0011_00	13	1		L01_3_90714	59259598	1				
59256999	H.01.02.A0011_03	18	1	92243685	L01_0_23182	92243685	1				
	H01_1_59887	59256999	1		L01_1_27708	92243685	0				
	H01_2_67804	59256999	1		L01_2_60486	92243685	1				
59257151	I01_1_32971	59257151	1		L01_3_90714	92243685	1				
	I01_2_67839	59257151	1	92457794	L01_0_23182	92457794	1				
59257162	I.01.02.A0011_03	23	1		L01_1_27708	92457794	0				
59257409	H.01.02.A0011_03	32	1		L01_2_60486	92457794	1				
	H01_0_22844	59257409	1		L01_3_90714	92457794	1				